

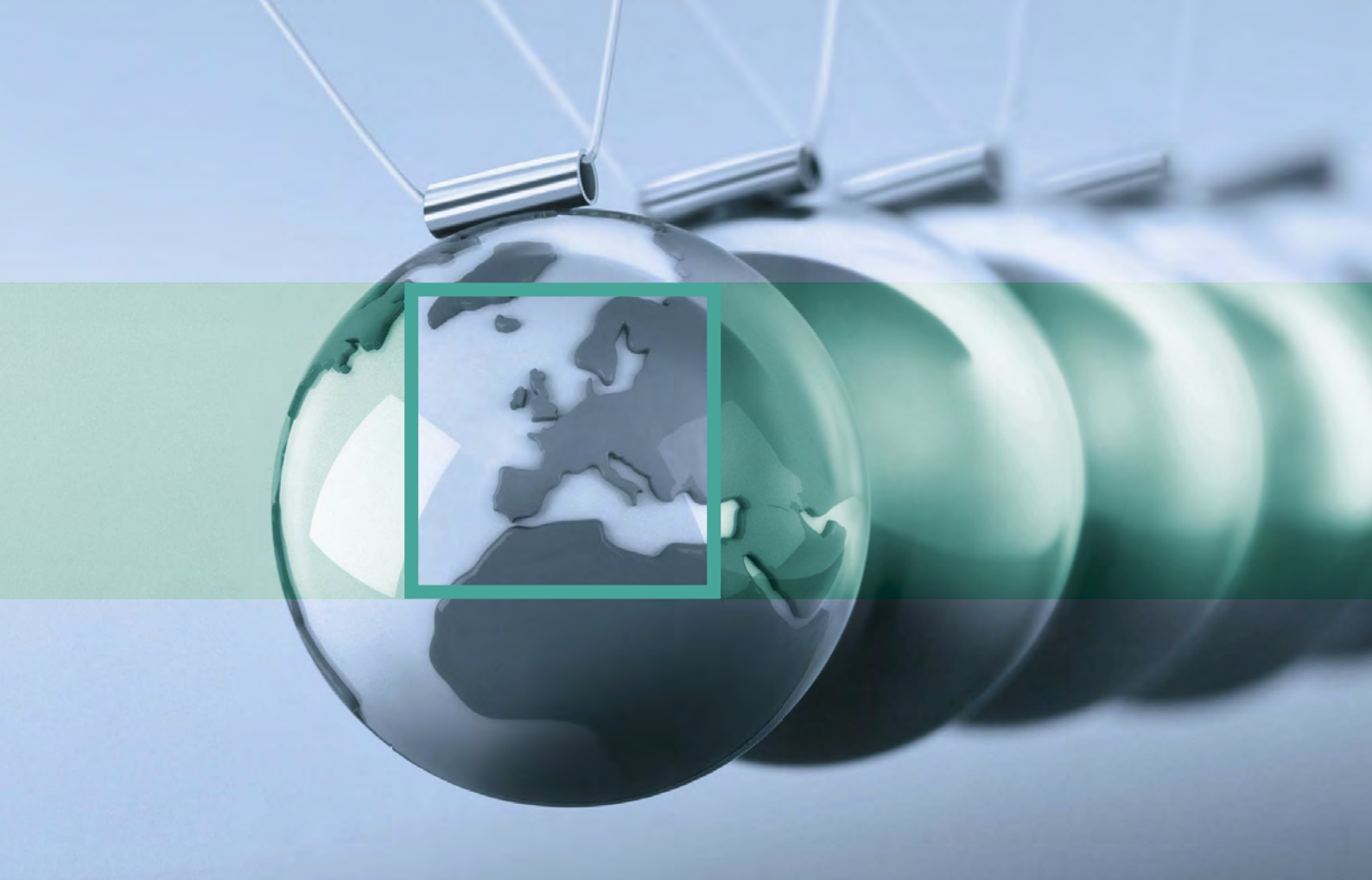

# LB/FB REMOTE I/O SYSTEMS ENGINEER'S GUIDE





## About Pepperl+Fuchs

Pepperl+Fuchs is a leading developer and manufacturer of electronic sensors and components for the global automation market. Since more than 60 years, our continuous innovation, high quality products, and steady growth guarantee continued success.

## One Company – Two Divisions

### PEPPERL+FUCHS – PROTECTING YOUR PROCESS

The **Process Automation Division** is a market leader in intrinsically safe explosion protection. We offer comprehensive, application-oriented system solutions, including customer-specific control cabinet solutions for the process industry. A large portfolio of components is available from our various product lines: isolated barriers, fieldbus infrastructure solutions, remote I/O systems, HART interface solutions, level measurement devices, purge and pressurization systems, industrial monitors and HMI solutions, power supplies, separator alarm systems for oil and petrol separators, hazardous area enclosures and equipment.

### PEPPERL+FUCHS – SENSING YOUR NEEDS

The main target markets of the **Factory Automation Division** are machine and plant construction, the automotive industry, storage and material handling, printing and paper industry, packaging technology, process equipment, door, gate and elevator construction, mobile equipment, renewable energies. With the invention of the inductive proximity sensor in 1958, the company set an important milestone in the development of automation technology. Under the motto “Sensing your needs”, customers benefit from tailor-made sensor solutions for factory automation. The division offers a wide product range of industrial sensors whether it’s inductive, photoelectric or ultrasonic sensors, rotary encoders, identification systems, barcode readers for 1D, 2D and data matrix codes, and vision sensors.

## We're There When You Need Us

A global presence enables Pepperl+Fuchs to offer the best of both worlds: extremely high engineering standards combined with efficient, low-cost manufacturing facilities.

A worldwide presence means we have exactly what you need to make your process efficient and reliable. It means the most advanced technical expertise in the business is standard with every Pepperl+Fuchs product.

It means we have the largest and most ingenious staff of seasoned and skilled engineers and field representatives in the industry. It means we're there when you need us – anywhere in the world.

Pepperl+Fuchs offers proven industry expertise through market-based, customer-focused products that provide answers to the toughest application problems. Our target industries are involved with chemicals, pharmaceuticals, oil and gas, petrochemicals, and other areas including wastewater treatment and power technology. In all industrial areas, Pepperl+Fuchs is both a supplier and partner for end users, control systems manufacturers, system integrators and engineering contractors. We set the standard by offering the best product, service and support in the world. From our expert application analysis and global key account management, to our on-site engineering of new systems and technical support after the sale, we stand solidly behind every product we build.

### Germany

Committed to engineering excellence, our worldwide headquarters is located in Mannheim, Germany. More than 600 specialists are dedicated to continuing our heritage of high quality and innovation.



**North and Central America**  
Twinsburg, Ohio, USA



**Asia Pacific**  
Singapore



**Western Europe**  
Antwerp, Belgium



**Middle East and India**  
Dubai



**Northern Europe**  
Oldham, UK



**Southern and Eastern Europe**  
Milan, Italy



**South America**  
São Paulo, Brazil



## Interface Technology

---

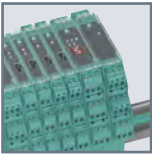

Interface technology guarantees a safe, reliable, and efficient signal transmission between your field device and the control system. We offer intrinsic safety isolated barriers, HART Interface Solutions, and Zener Barriers in DIN rail styles or Termination Board solutions, signal conditioners for general-purpose areas, and a wide variety of power supplies and accessories.

## Fieldbus Infrastructure

---



FieldConnex® is a comprehensive fieldbus infrastructure that provides solutions for connecting your instruments to a controller. A wide range of interface products are designed for fast installation and commissioning. A unique High-Power Trunk concept uses Segment Protectors and FieldBarriers to provide power to each device. The Advanced Diagnostic Module lets you monitor the physical layer remotely, in real time.

## Remote I/O Systems

---



Remote I/O Systems provide a way to communicate effectively with a modern DCS and proven legacy field devices. RPI and LB/FB Remote I/O connect a wide range of digital and analog sensors and actuators to process control systems over a fieldbus. A variety of gateways are available to make use of different bus protocols.

## Purge and Pressurization

---



Purge and pressurization products offer a safe and economical approach to installing electrical equipment in hazardous locations. By creating a safe area inside an enclosure, general-purpose equipment can be used in hazardous areas. Pepperl+Fuchs offers a full range of Type X, Y, Z, Ex nP, and Ex px purge and pressurization equipment for use in Zones/Divisions 1 and 2.

## Level Measurement and Corrosion Monitoring

---



Level measurement devices are available in 4 mA ... 20 mA, FOUNDATION Fieldbus and PROFIBUS PA interfaces. They are designed for point and continuous applications and are suitable for a wide range of materials and industries. CorrTran MV is a 2-wire, multivariable HART transmitter that evaluates general and localized (pitting) corrosion on line and in real time.

## Industrial Monitors and HMI Solutions

---



Industrial Monitors and HMI Solutions enable optimum control, operation, and monitoring of production processes. Our product line provides industrial PC components and visualization equipment used in hazardous areas focusing on equipment used for the human interface to automation systems. These include intrinsically safe electronic display and control device systems, Ex PC systems, intrinsically safe weighing and dosing terminals, and intrinsically safe data collection systems.

## Hazardous Area Enclosures and Equipment

---



Our cabinet solutions unit offers expert development, manufacture and commissioning of a wide range of solutions including marshalling cabinets, displays and annunciators, distribution panels, control room cabinets, fieldbus panels, custom operator interface solutions, standard and customer fieldbus junction boxes and fieldbus power cabinets as well as standard and customized Remote I/O enclosures.

### Intrinsic Safety



Intrinsic safety (IS) is a protection technique used within various hardware packages that limits the energy within an electronic circuit to a point that is safe to operate within a hazardous (explosive) location. IS forms the front end of every Remote I/O.

### Standard Bus Technologies



A variety of bus technologies are employed throughout the industry. PROFIBUS, MODBUS, FOUNDATION Fieldbus, and the Ethernet ensure reliable exchange of digital information between the control system and Remote I/O.

### HART Interface Solutions



HART (Highway Addressable Remote Transducer) is a popular digital, fieldbus protocol that solves a wide range of applications. It is used to communicate with field devices, configure and monitor the status of the system, and indicate process variables.

### System Integration



System integration forms a vital part of Remote I/O technology. The user can configure both the Remote I/O and the field devices from the system's own workstation or a secondary central operating console.

### Signal Conditioning







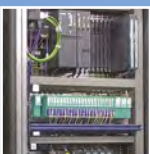

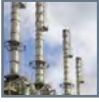

Signal conditioning is an important part of any automation system where electrical isolation, electronic signal conversion, and measurement accuracy are critical characteristics of the control loop architecture. This is one of the tasks Remote I/O fulfill.

### Engineered Solutions



Our experienced project engineers assist you from the beginning through to the FAT and commissioning stages. Remote I/O cabinets are manufactured to the highest international standards. We also ensure that explosion protection requirements are satisfied covering permitted maximum surface temperatures for Zone mounting. This includes standard panels as well as customized enclosures. Solutions can include displays and annunciators, distribution panels, and operator workstations.



|   |            |
|---|------------|
| <b>Introduction</b>   | <b>6</b>   |
| <hr/>   |            |
| <b>Technology</b>   | <b>8</b>   |
| <hr/>   |            |
|  <b>Basic Principles</b>   | <b>11</b>  |
| <b>Applications and Practical Solutions</b>   | <b>29</b>  |
| <b>Explosion Protection and Intrinsic Safety</b>  | <b>41</b>  |
| <b>Functional Safety (SIL)</b>  | <b>91</b>  |
| <hr/>   |            |
| <b>Remote I/O Isolated Barriers</b>   | <b>100</b> |
| <hr/>   |            |
|  <b>LB Remote I/O for Safe Areas or Zone 2, Zone 22, Div. 2</b>    | <b>102</b> |
|  <b>FB Remote I/O for Zone 1, or Zone 21</b>                       | <b>192</b> |
| <hr/>   |            |
| <b>FOUNDATION Fieldbus Modular I/O</b>  | <b>266</b> |
| <hr/>   |            |
|  <b>LB Modular I/O for Safe Areas or Zone 2, Zone 22, Div. 2</b> | <b>268</b> |
|  <b>FB Modular I/O for Zone 1, or Zone 21</b>                    | <b>268</b> |
| <hr/>   |            |
| <b>PROFIBUS Fiber Optic Coupler and Repeater for Zone 1, or Zone 21</b>   | <b>284</b> |
| <hr/>   |            |
|  <b>PROFIBUS Fibre Optic Link FOL</b>                            | <b>286</b> |
| <hr/>   |            |
| <b>Multi Function Terminal</b>  | <b>292</b> |
| <hr/>   |            |
|  <b>Multi Function Terminal MFT</b>                              | <b>294</b> |
| <hr/>   |            |
| <b>Appendix</b>   | <b>300</b> |
| <hr/>   |            |
|  <b>Glossary</b>   | <b>303</b> |
| <b>Function Index</b>   | <b>323</b> |
| <b>Model Number Index</b>   | <b>333</b> |

We are pleased you have selected the Pepperl+Fuchs' Remote I/O Engineer's Guide as your application and solution reference. This Engineer's Guide is much more than a catalog of data sheets and specifications. It contains a wealth of information on hazardous locations, intrinsic safety technology, basic principles, applications, and functional safety. We hope this Engineer's Guide is used a valuable resource in your daily activities and that Pepperl+Fuchs is your first choice for Remote I/O technology for the Process Automation industry.

### Technology



The Technology portion of this catalog is divided into sections: Introduction into Intrinsic Safety and other explosion protection methods, Applications and Practical Solutions, plus invaluable information on Safety Integrity Levels (SIL). Furthermore Bus Protocols are explained as well as System Integration and HART Communication. There is also a section on Engineered Solutions.

The **Intrinsic Safety** and Explosion Protection Overview contains a detailed analysis of hazardous locations and the protection methods used to safely operate equipment within ignition capable areas. It provides a full analysis of intrinsic safety protection including its history, development, operating principals, and standards. It also outlines other safeguarding methods.

The SIL section discusses **Functional Safety** and provides a brief overview of SIL within the process industry. The key standards are summarized and many of the important terms and definitions are discussed including **Probability of Failure on Demand (PFD)**,  $T_{proof}$ , and **Safe Failure Fraction (SFF)**. Some examples involving Pepperl+Fuchs products are also analyzed in order to provide a clear understanding of how our equipment can be used in SIL loops.

As part of the **Application and Practical Solutions** section, the major process applications are detailed in easy-to-read and easy-to-understand examples using many of the products contained in this Engineer's Guide. This section summarizes applications for digital and analog inputs and outputs. It should be used whenever you require application assistance for any of the day to day tasks planning and maintenance engineers come across.

**Bus Protocols** and their basic principles are explained next. The section concentrates on the practical aspects relevant to Remote I/O applications. This acts as a quick reference for the reader to view the different bus technologies without having to go into too much detail.

The **System Integration** section shows how Remote I/O can be easily integrated into the various process control systems. Configuration and parameterization as well as online configuration are discussed.

**HART Communication** is one of the bonus features of Remote I/O. It can be used on top of the 4 mA ... 20 mA current loops which are employed for analog inputs from flow, level, pressure, and differential pressure transmitters as well as for outputs to positioners, I/P converters, proportional valves, and analog indicators. Remote I/O renders handheld HART communicators superflous since all the tasks can be performed via the bus.

**Engineered Solutions** for Remote I/O applications are outlined in the last section extending to standard and custom built enclosures and cabinets as well as combinations with our range of hazardous area mounted display systems. The section also shows how to ensure that explosion protection requirements are satisfied.

### Symbology



The following chart shows electrical symbols used in the connection diagrams:

|                                       |                  |                    |                |                           |                |               |                  |             |                          |
|---------------------------------------|------------------|--------------------|----------------|---------------------------|----------------|---------------|------------------|-------------|--------------------------|
|                                       |                  |                    |                |                           |                |               |                  |             |                          |
| TC                                    | Jumper           | RTD                | Resistor       | Potentiometer             | Strain gauge   | Level control | Vibration sensor | Fire alarm  | Lead monitoring          |
|                                       |                  |                    |                |                           |                |               |                  |             |                          |
| Normally open contact                 | Namur sensor     | Magnetic pick-up   | Voltage source | Current source            | Solenoid       | I/P device    | Horn             | Transmitter | Field device             |
|                                       |                  |                    |                |                           |                |               |                  |             |                          |
| Signal converter With elec. Isolation | Signal converter | Changeover contact | Transistor     | Current source with shunt | Function block | Zener diode   | LED              | Ground      | Replaceable back-up fuse |

### Product Selection Tables



Product selection tables are located at the beginning of each section, making it easy to find the product you need.

### Product Data Pages



The product data sheets contain all of the relevant data necessary to select and specify the equipment. It includes four major sections: Features, Function, Technical Data, and Diagrams. Surrounding these key elements are navigation tools necessary to help identify the product including special colors, markings, and symbols. We hope you find the information valuable, accurate, and easy to understand.

### Product highlights

### Color-coded navigation tabs

- LB-System
- FB-System
- FF Modular I/O
- PROFIBUS Fibre Optic Link
- Multi Function Terminal
- Hazardous area products
- Safe area products

### Function description

### SIL rating designator

| Remote I/O Isolated Barriers |          |   |                |                    |                                     |                 |                            |  |                               | Selection Tables       |             |             |                                |                    |      |
|------------------------------|----------|---|----------------|--------------------|-------------------------------------|-----------------|----------------------------|--|-------------------------------|------------------------|-------------|-------------|--------------------------------|--------------------|------|
| Model Number                 | Channels |   | Occupied Slots | NAMUR/Dry Contacts | Frequency and Direction of Rotation | Up/Down Counter | Line Fault Detection (LFD) | Active Digital Signal 95 V AC ~ 230 V AC | Active Digital Signal 24 V DC | Time Stamping (Option) | Input Ex Ia | Input Ex Ic | Mounting in Zone 2 and Zone 22 | Mounting in Div. 2 | Page |
|                              | 1        | 2 |                |                    |                                     |                 |                            |  |                               |                        |             |             |                                |                    |      |
| LB 1001 A                    | 2        | 1 |                |                    |                                     |                 |                            |  |                               |                        |             |             |                                |                    | 112  |
| LB 1002 A                    | 3        | 1 |                |                    |                                     |                 |                            |  |                               |                        |             |             |                                |                    | 113  |
| LB 1003 *                    | 1        | 1 |                |                    |                                     |                 |                            |  |                               |                        |             |             |                                |                    | 114  |
| LB 1007 A                    | 7        | 1 |                |                    |                                     |                 |                            |  |                               |                        |             |             |                                |                    | 115  |
| LB 1008 A                    | 8        | 2 |                |                    |                                     |                 |                            |  |                               |                        |             |             |                                |                    | 116  |
| LB 1014 A                    | 15       | 2 |                |                    |                                     |                 |                            |  |                               |                        |             |             |                                |                    | 117  |
| LB 1015 A                    | 15       | 2 |                |                    |                                     |                 |                            |  |                               |                        |             |             |                                |                    | 118  |

Model number
Primary function

LB 2101 - LB 2113 SIL 2
Digital Output with Shutdown Input

**Features**

- 1 digital output, 2 digital inputs
- Inputs and output Ex ia
- Installation in Zone 2 and 22 or Div. 2 and safe area
- Module can be exchanged under voltage (hot swap)
- Positive or negative logic selectable
- Simulation mode for service operations (forcing)
- Line fault detection (LFD)
- Permanently self-monitoring
- Output with watch dog circuit
- Output with bus-independent safety shutdown
- EMC acc. to NAMUR NE 21
- Up to SIL2 acc. to IEC 61508

**Function**

The digital output features 1 output with 2 feedback inputs. The digital output can control a solenoid valve, a sounder or an indicator (without line fault detection) in the field. Additionally, it accepts 2 digital input signals of NAMUR sensors or mechanical contacts from the field. The output can be switched off via a contact. This can be used for bus-independent safety applications. Open or short circuit line fault alarms are detected. The intrinsically safe inputs and the output are galvanically isolated from the bus and the power supply (IEC/EN 60079-11).

**Technical data**

|   |  |
|---|--|
| <b>Supply</b>   |  |
| Rated voltage   | 12 V DC, only in connection with the power supplies LB 9***  |
| Power consumption   | 0.52 ... 1.8 W, depending on model   |
| <b>Input</b>  |  |
| Number of channels  | 2  |
| Rated voltage   | acc. to EN 60947-5-6 (NAMUR)   |
| Switching point/switching hysteresis                            | 1.2 ... 2.1 mA/± 0.2 mA  |
| Line fault detection  | option: On/Off, for each channel mechanical switches; see connection diagram NAMUR proximity switches; no replacement network required |
| Internal resistor   | approx. 1 kΩ   |
| <b>Output</b>   |  |
| Number of channels  | 1  |
| Operating frequency   | 0 ... 50 Hz, depending on the process control system   |
| Line fault detection  | option: On/Off, see connection diagram   |
| Watch dog   | Output OFF 0.5 s after serious fault   |
| <b>Ambient conditions</b>                                       |  |
| Ambient temperature   | -20 ... 60 °C (-4 ... 140 °F)  |
| <b>Mechanical specifications</b>                                |  |
| Mass  | approx. 110 g  |
| Dimensions  | 16 x 100 x 103 mm (0.63 x 3.9 x 4 in)  |
| <b>Data for application in connection with Ex-areas</b>         |  |
| EC-Type Examination Certificate                                 | PTB 03 ATEX 2042   |
| Group, category, type of protection                             | (II) (1) G [Ex ia] IIC/IB, (II) (1) D [Ex ia] D  |
| Supply  | only in connection with the power supplies LB 9***   |
| Declaration of conformity                                       | PF 08 CERT 1234  |
| Group, category, type of protection, temperature classification | (II) 3 G Ex nA IIC/IB T4   |
| <b>Directive conformity</b>                                     |  |
| Directive 94/9/IEC  | EN 60079-0, EN 60079-11, EN 60079-15, EN 60079-26, EN 61241-0, EN 61241-11   |
| <b>International approvals</b>                                  |  |
| UL approval   | E105378  |
| IECEX approval  | BVS 09.0037X, BVS 08.0011X   |

**Diagrams**

Front view

LED red: Line fault  
LED green: Power supply  
LED yellow: Signal (status)

Space for labelling

Socket for removable plug blue (accessory)

Zone 2, Div. 1

Zone 2, Div. 2

126 Subject to modifications without notice Copyright © Pepperl+Fuchs

Pepperl+Fuchs Group USA +1 330 486 0002 Germany +49 621 776 2222 Singapore +65 6779 9091

www.pepperl-fuchs.com pe-info@us.pepperl-fuchs.com pe-info@de.pepperl-fuchs.com pe-info@sg.pepperl-fuchs.com

Front view drawing

Connection diagram

7



# Technology



Edition 912907 (US) / 220718 (EU) 06/2011

|  |           |   |
|--|-----------|---|
| <b>Basic Principles</b> .....  | <b>11</b> | <b>Technology</b>                         |
| Bus Technology .....   | 11        |   |
| Online Configuration .....   | 13        |   |
| Redundancy .....   | 14        |   |
| Sizing Guidelines .....  | 17        |   |
| System Integration and Life Cycle Management .....                                 | 19        |   |
| PACT <sup>ware</sup> ™ – One Configuration Tool for all Instruments .....          | 20        |   |
| HART Communication .....   | 23        | <b>Basic Principles</b>                   |
| <b>Applications and Practical Solutions</b> .....                                  | <b>29</b> |   |
| Standard and Customized Solutions .....  | 29        |   |
| Remote I/O Isolated Barriers .....   | 33        | <b>Applications</b>                       |
| Gateway or Com Unit Selection Guide .....  | 39        |   |
| <b>Overview of Explosion Protection and Intrinsic Safety</b> .....                 | <b>41</b> |   |
| Introduction .....   | 41        |   |
| Introduction to Intrinsic Safety .....   | 41        |   |
| Physical Fundamentals of Explosion Protection .....                                | 42        |   |
| Classification of Hazardous Areas .....  | 44        |   |
| Ignition Protection Methods .....  | 47        |   |
| Labeling of Explosion Protection Methods .....                                     | 55        |   |
| The Philosophy of Intrinsic Safety .....   | 56        |   |
| Intrinsically Safe Systems .....   | 59        | <b>Ex Protection<br/>Intrinsic Safety</b> |
| Proof of Intrinsically Safe Systems .....  | 63        |   |
| Installation of Intrinsically Safe and Associated Apparatus .....                  | 65        |   |
| Legal Situation .....  | 69        | <b>Functional<br/>Safety</b>              |
| Testing and Maintaining of Intrinsically Safe Systems .....                        | 71        |   |
| A new Dimension of Intrinsic Safety with DART .....                                | 72        |   |
| Application Practice .....   | 76        |   |
| Additional Information .....   | 81        | <b>Functional<br/>Safety</b>              |
| Special Considerations Regarding Remote I/O Installations in Hazardous Areas ..... | 87        |   |

Technology

Basic Principles

Applications

Ex Protection  
Intrinsic Safety

Functional  
Safety

**Functional Safety (SIL) . . . . .91**

    Risk . . . . . 91

    Protective Measures on Different Levels . . . . . 91

    Risk Analysis . . . . . 91

    Safety Integrity Level (SIL) . . . . . 92

    Low Demand and High Demand Mode . . . . . 92

    PFD Value . . . . . 93

    SFF and HFT . . . . . 93

    Failure Types . . . . . 93

    Measures to Increase the SIL of a Safety System . . . . . 95

    Questions about SIL . . . . . 95

    SIL in Process Automation . . . . . 96

    Summary . . . . . 96

    Pepperl+Fuchs and SIL . . . . . 97

    Bus-Independent Functional Safety . . . . . 98

Edition 912907 (US) / 220718 (EU) 05/2011

# Basic Principles

## Bus Technology

### Introduction

LB/FB Remote I/O bring intrinsically safe inputs and outputs from sensors and actuators to all kinds of busses as listed below. They accept signals from NAMUR and switch type inputs and drive high power IS solenoids or even increased safety power relays as well as sounders, and alarm LEDs. They supply 4 mA ... 20 mA transmitters and accept inputs from 20 mA current sources or temperature sensors. They also drive I/P converters and proportional valves as well as positioners.

Remote I/O employ a variety of bus technologies to communicate with the master DCS, PLC or SCADA system.

The most popular ones are

- PROFIBUS, DP or DP V1
- MODBUS RTU
- FOUNDATION Fieldbus
- Ethernet using MODBUS TCP.

These busses rely on standardized protocols and standardized physical layers. PROFIBUS and MODBUS protocols employ RS 485 hardware while FOUNDATION Fieldbus uses a bus powered approach. MODBUS TCP draws on industrial Ethernet technologies.

Bus technology offers the following advantages over conventional instrumentation:

- Savings on wiring, engineering and installation costs
- Improved control and diagnostics
- Remote access to HART field devices
- Suitable for safe area and hazardous area applications
- Ensures high availability through redundancy

The following paragraphs will give a brief insight into the various protocols and hardware platforms. Further details can be taken from the literature.

### PROFIBUS DP

PROFIBUS may rightfully claim to be the world's most successful fieldbus with more than 30 million nodes installed. A shielded twisted pair cable can transmit hundreds of signals over long distances at high speed.

|                |        |
|----------------|--------|
| 1.5 mio. Bit/s | 200 m  |
| 500 kBit/s     | 400 m  |
| 187.5 kBit/s   | 1000 m |
| 93.75 kBit/s   | 1200 m |
| 19.2 kBit/s    | 1200 m |
| 9.6 kBit/s     | 1200 m |

Table 1 Relationship between transmission speed and distance

It shows that the distance varies with the transmission speed. Longer distances can be achieved using fiber optic links.

The RS 485 hardware uses a line structure with bus nodes connected in parallel. At the beginning and at the end of a line termination networks have to be fitted. These have to be connected to a 5 V source which is normally presented by the first and last participant on the bus.

The termination will avoid reflections which might otherwise distort the digital signals and even render communication impossible.

The RS 485 architecture does not permit the use of spurs or chicken foot structures unless repeaters are used to regenerate the signal at the beginning of each bus segment.

No more than 3 ... 5 repeaters should be connected in series to avoid time delays which again might render communication impossible.

The PROFIBUS protocol can accommodate 244 Bytes of input and 244 Bytes of output data. It works on the master/slave principle where the master sequentially addresses the slaves to exchange data with them.

A maximum of 32 slaves can be connected to the bus without repeaters. As a Remote I/O offers up to 80 analog channels or even 184 digital ones, the number of nodes is often less than 32. This still yields something like 800 analog or 2,000 digital signals or their combination on a single bus line.

On the whole both hardware and software ensure a secure transmission path for the data, provided the rules of installation are observed.

### PROFIBUS DP V1

DP V1 is the enhanced version of PROFIBUS using the same hardware. It makes use of gaps in the cyclic DP communication. It is fully compatible with PROFIBUS DP and can use the same path to address the same slaves from a secondary DP V1 master, the so called class 2 master. The non cyclic communications are often used for configuration, commissioning, maintenance or for additional diagnostics. This stretches to asset management and HART communications with suitable field devices.

### PROFIBUS PA

PROFIBUS PA again is fully compatible with PROFIBUS DP and also sends its data via the same transmission channels. At one point however there is a converter or segment coupler which forms the starting point of the bus powered PROFIBUS PA. Originally this bus was intended as the intrinsically safe fieldbus version of PROFIBUS. Today PROFIBUS is also used for non IS applications.

In contrast to the high speed PROFIBUS DP/DP V1 the PA bus not only communicates with the field devices via a shielded twisted pair but also supplies energy to the field devices at the same time.

PROFIBUS PA permits the use of spurs and chicken foot structures.

The maximum distance PROFIBUS PA can cover is 1,900 m at 31.25 kBd. The distance largely depends on the bus architecture and the number of devices connected to it.

Theoretically 32 devices can be connected to the bus. In practice one often does not go beyond 16 nodes to arrive at reasonable bus lengths. The vast amount of data available from each field device also limits the number of devices to ensure a suitable communication speed.

For further details refer to [www.profibus.com](http://www.profibus.com).

### MODBUS RTU

MODBUS uses the same RS 485 hardware backbone as PROFIBUS. Therefore the same considerations regarding line structure, bus termination and bus extension apply.

MODBUS RTU Remote I/O operate at 19.2 kBit/s or 38.4 kBit/s allowing for a maximum cable length of 1,200 m.

MODBUS also employs the master/slave principle where the master DCS or PLC addresses registers or coils in the slaves to exchange data. MODBUS is a well proven open protocol on offer by many system vendors. Unlike PROFIBUS PA there is no dedicated fieldbus version of MODBUS.

For details refer to [www.modbus.org](http://www.modbus.org).

### FOUNDATION Fieldbus

Just like PROFIBUS PA the hardware backbone of FOUNDATION Fieldbus also permits the use of spurs and chicken foot structures. They are both based on IEC 61158-2 standards.

The maximum distance FOUNDATION Fieldbus can cover is 1,900 m at 31.25 kBd. The distance largely depends on the bus architecture and the number of devices connected to it.

Theoretically 32 devices can be connected to the bus. In practice one usually does not go beyond 12 nodes to arrive at a reasonable bus length. The vast amount of data available from each field device also limits the number of devices to ensure a suitable communication speed.

There is a more detailed chapter on FOUNDATION Fieldbus as an introduction to the data on our FOUNDATION Fieldbus Modular I/O.

For further details refer to [www.fieldbus.org](http://www.fieldbus.org).

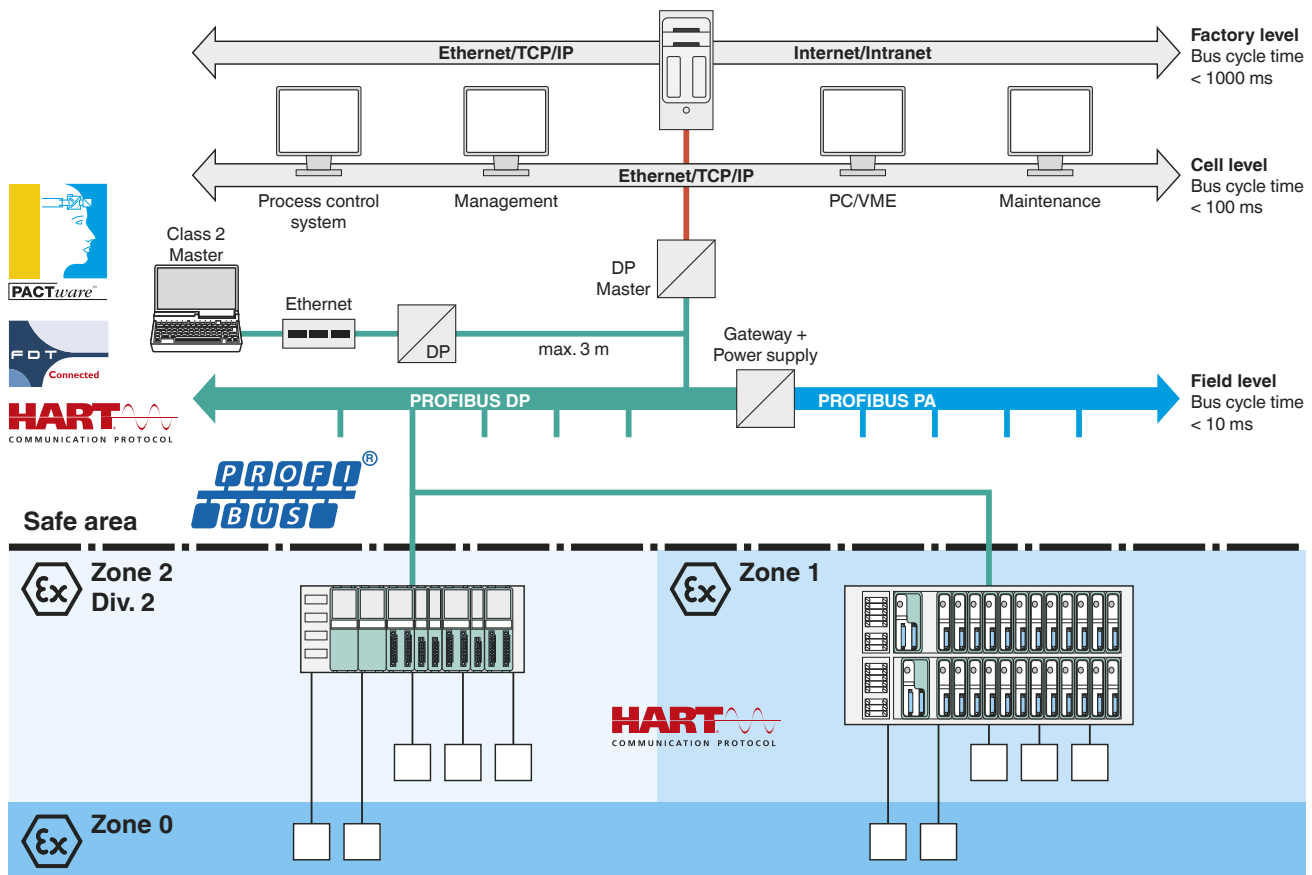

Figure 1 Overview bus technology

Edition 912907 (US) / 220718 (EU) 06/2011

## Ethernet/MODBUS TCP

MODBUS TCP uses industrial Ethernet as the hardware backbone. Standard MODBUS function blocks are used for communication. Ethernet TCP/IP based simple client/server networks are employed. The topology is very flexible with star, tree or line structures. These can all be implemented with standard Ethernet technology including switched networks. Connections are always point to point. Unlike RS 485 busses there is never a chain of participants connected in parallel.

Network transmission speeds vary from 10, 100 or 1000 Mbit/s based on copper cables, fibre optics or wireless standards. Refer to the LB/FB Remote I/O gateway data sheets for the available options.

The number of stations in a network is almost unlimited but overall system speed needs to be considered.

The distance between participants in a network made up of copper connections is limited to 100 m depending on the baud rate. Fibre optics can bridge distances of 1,000 m or more at high speed.

For further details refer to [www.modbus.org](http://www.modbus.org).

## Online Configuration

### General

Online configuration is one of the prerequisites for process automation. It means that changes to a running system are possible at any time. This also applies to bus systems.

Now PROFIBUS is based on fixed data structures. Therefore a reset is initiated every time the data structure changes. This is indeed a rare occasion for field devices but quite common for Remote I/O. Each Remote I/O module has its own data telegram depending on the amount of data to be transmitted and whether it is an input or output device. So changing or adding or removing a device would inevitably lead to a change in the data structure and subsequently to a reset.

A PROFIBUS reset in turn causes Remote I/O data to be driven to Zero with disastrous effects for some process applications if conducted while the system is running. It therefore became necessary for Remote I/O to develop methods to overcome this obstacle.

### Pre-Configuration

One possibility to prevent a PROFIBUS reset is to pre-configure a Remote I/O for its anticipated future tasks. An input or output device can then be declared passive with its data structure remaining unchanged but not containing any meaningful information. The device need not even be fitted and can be purchased later when required.

The advantage of this method lies clearly in the fact that the module can be activated at any time without changing the data structure and thus preventing a PROFIBUS reset. Online changes would therefore not be a problem. However, future requirements are often not known beforehand in a process application and the pre-configured device may possibly be the wrong one. By way of example for the much needed digital input a pre-configured analog input would be quite useless. Pre-configuration is therefore not the best possible approach to online configuration.

### Hot Configuration in Run (HCiR)

Another means to ensure that a PROFIBUS reset would not cause signals to respond in an uncontrolled fashion is to introduce hot configuration in run (HCiR). This is based on freezing output data during the PROFIBUS reset period to prevent valves from shutting down unnecessarily. At the same time input data to the system would have to be prevented to cause unwanted results. Some DCS systems would support this feature others would not.

In some cases even this on its own was not sufficient. Changing a Remote I/O configuration requires both master and slave to be reconfigured. As this is a manual process it may take some time. As it is usually unacceptable to freeze a technical process for longer periods an additional feature had to be introduced.

The Remote I/O gateway had to be capable of storing two sets of configuration data, the current active version and the new future configuration. A mechanism then makes sure that once the master configuration is changed and downloaded the new slave configuration becomes active.

Some DCS vendors can apply this method while others need a redundant system to be able to cope.

### Configuration in Run (CiR)

An alternative can be seen in the method of "configuration in run". Some systems have adopted this by using a blank pre-configuration for a maximum number of slots placed behind the last active module in a PROFIBUS slave. The configuration of this limited number of devices can later be adapted to the required I/O module one by one without causing a PROFIBUS reset.

Pepperl+Fuchs has refined this approach by allowing any number of slots anywhere in the Remote I/O to be changed online at any time. This is achieved by configuring the slave using so called universal modules which simply cover the data structure of all I/O modules. So when a new module is activated its data structure is already in place. The new module can be an input or an output device it can be analog or digital.

As this method relies on the maximum required amount of data per slot it always makes use of the full capacity of the PROFIBUS data string. It transmits more data than would be necessary with a fixed configuration as an input device does not normally have output data and vice versa. Subsequently it poses some small restrictions on the maximum number of channels that can be installed. However, universal modules offer the big advantage of working reliably with any DCS in single or redundant modes.

The method can be applied in combination with the original fixed configuration per slot offering the full hardware capacity of 80 analog or 184 digital channels or a combination to be used.

### Auto-Configuration

Remote I/O work with intelligent gateways or Com Units. They have built-in device recognition features. The gateway can detect if a module has been placed in the wrong slot. Equally it activates a correct replacement device without the user having to take any further action.

The I/O modules have neither switches nor potentiometers. When an I/O module is replaced, the new module automatically adopts the configuration of the previous module (provided the same type of module is used). Parameterization takes place once during commissioning and the parameters are stored in the non-volatile memory of the Com Unit.

Equally a redundant Com Unit or gateway can be hot swapped at any time without interruption provided the new Com Unit has the same hardware and firmware version as its predecessor.

## Redundancy

Redundancy is used in order to ensure that a Remote I/O station can continue to work even when there is a fault in a master, in a bus line, in a Com Unit, or in a power supply. LB/FB Remote I/O offer all these redundancy options.

Redundancy is being successfully applied with all major process control systems. The high level of availability is achieved internally by means of segmenting and redundant access from the gateway or Com Units to each module.

Gateway redundancy is based on two identical devices being connected to the master. A standby power supply ensures power supply redundancy and two bus lines allow the higher-level system to switch over to the redundant bus if the primary line fails.

### Line Redundancy

A Remote I/O station (slave) features two redundant Com Units or gateways. The bus is also redundant. The latter is sometimes called media redundancy. The master of a line redundant system is usually a single, non redundant master which uses an electronic switch or two repeaters to address the redundant slave. This type of redundancy can therefore be used with most DCS or PLC systems as the master will see the slave under one address not even knowing that it is a redundant device.

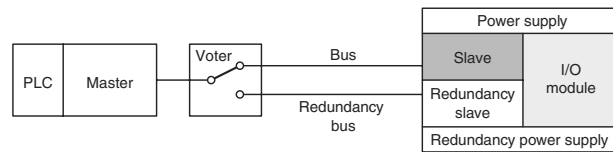

Figure 2 Principle of line redundancy: a master communicates with redundant slaves via a voter

On the backplane-internal bus, only one Com Unit at a time is actively connected to the master and thus authorized to set outputs. The passive Com Unit continuously reads both the data traffic on the internal bus and also the traffic from the adjacent (active) Com Unit. If a Com Unit is replaced by a Com Unit configured for line redundancy, it automatically adopts the configuration of the primary Com Unit.

In line redundancy, the currently active Com Unit exchanges read and write information with the master. This is independent of which of the two bus lines is used. This method ensures master/slave communication even when several Com Units fail in different stations. The diagram below illustrates the principle of extended line redundancy.

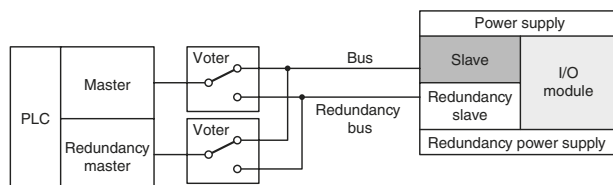

Figure 3 Principle of extended line redundancy: DCS with redundant master master communicating with redundant slaves via two voters or four repeaters

### Redundant Remote I/O for Non-Redundant PROFIBUS Hosts

Although some DCS manufacturers do not offer redundant PROFIBUS cards yet, redundancy is possible. There are two different options for this type of application. In both cases our Com Units are set to the line redundancy mode. This means that only the active Com Unit communicates with the PROFIBUS master, and the passive Com Unit is in standby mode ready to take over communications. With output drivers blocked in the passive mode, the two Com Units avoid telegram collisions. In general this line redundant solution is completely transparent for the PROFIBUS master application. Seen from the PROFIBUS master, you can detect only one PROFIBUS device, although it consists of two Com Units.

The diagnostic data of the passive Com Unit is transferred via the active Com Unit. All diagnostic messages, which start with "Red.Com...", originate in the passive Com Unit and are exchanged between the Com Units via an internal communication link.

#### Redundancy Option 1

Increased availability and electrical isolation of the two bus lines can be achieved by a PROFIBUS voter like the RLM 01 (Redundancy Link Module) from ABB. This is directly connected to the non redundant master DP card and to both PROFIBUS lines which are running to the field (see Figure 4, A = active, P = passive).

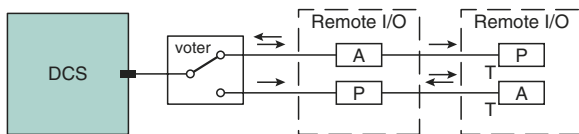

Figure 4 Line redundancy with voter

The voter has redundant terminals for the 24 V power connection and a relay output that gives you the possibility to identify line errors. Due to the fact that there may be active Com Units on both PROFIBUS lines the voter communicates on both fieldbus lines.

If a gateway fails, or a bus line fails, the master DCS will always have access to the Remote I/O slave via the redundant line.

#### Redundancy Option 2

For some applications it may not be acceptable to use a voter as presented in the previous option. It may be argued that the voter is a single point of failure in a redundant system. In this case the LB/FB Remote I/O can again be used in line redundant mode adding standard PROFIBUS repeaters for each line. The Com Units themselves avoid telegram collisions on the bus. The intelligent PROFIBUS repeaters allow you to build another kind of redundant network (see Figure 5, A = active, P = passive). They use telegram detection to decide if the telegrams on the bus are valid.

If a gateway fails, a bus line fails, or a repeater fails, the master DCS will always have access to the Remote I/O slave via the redundant line. The repeater can be replaced by a fibre optic link.

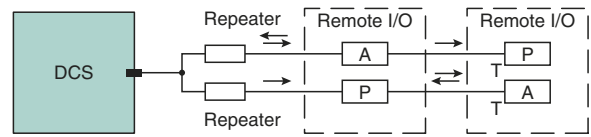

Figure 5 Line redundancy without voter

### Application Redundancy

A Remote I/O station (slave) contains two redundant Com Units or gateways. The bus is also redundant.

The master of an application redundant system is a redundant master which uses application software to switch bus lines to address redundant slaves. This type of redundancy can therefore only be used with DCS or PLC systems where the master has the capability to perform this task.

The Com Unit can be switched over by command from the master or through automatic action initiated by the Com Units themselves. This will happen when either the master or a slave detect a fault in the bus line or in one of the redundant masters or slaves.

Both Com Units are active on the two external buses. Only one Com Unit is active on the internal bus and only this one is allowed to set outputs.

In case of a redundancy switch the whole bus line is switched over to the line of the active Com Unit.

At the same time all Com Units on this bus line become active Com Units with write access to the internal bus of the field stations. In this case the faulty bus line or Com Unit must be repaired very soon, because this system cannot handle another fault on the bus line that is now active.

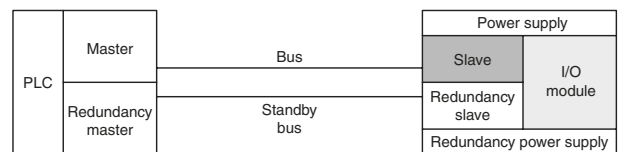

Figure 6 Principle of application redundancy: the redundant master of the DCS communicates with the redundant stations via the redundant bus

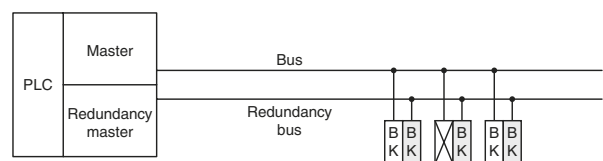

Figure 7 Bus after the redundancy switchover with activated redundant Com Units (BK). Faulty primary Com Unit X

Edition 912907 (US) / 220718 (EU) 06/2011



### Master Redundancy

As we have seen application redundancy works on the basis of redundant masters. This feature therefore depends on the master DCS offering this type of redundancy. Pepperl+Fuchs offers proven solutions with a number of DCS vendors for both PROFIBUS and MODBUS systems. New applications can be found and tested at our laboratories.

### Internal Backplane Redundancy

The Remote I/O backplanes are designed to work in redundant systems. The redundant Com Units control the I/O modules over an internal bus with each Com Unit having two paths to reach a module. Redundant selectors SE are provided for this purpose. Furthermore the backplane is divided into six segments for LB and four segments for FB. That way the 48 I/O slots are addressed via a pair of redundant selectors for each segment.

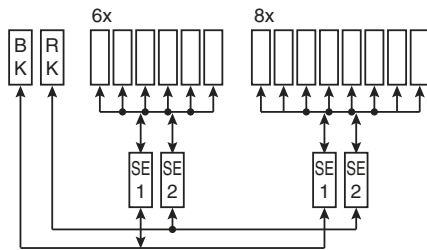

Figure 8 Redundant selectors per Com Unit for each segment of I/O modules

### Power Supply Redundancy

Two LB 9006 power supplies are enough to supply the whole backplane and the redundant Com Units.

The third power supply works in standby mode, so there is no interruption in supply if a power supply fails. A diagnostic message warns the process control system of the fault.

Zone 1 FB Remote I/O also feature power supply redundancy with redundant Com Units. Two power supplies each support one Com Unit. Should the power supply in the base unit fail, there is a bumpless switch over to the redundant Com Unit and power supply.

### Module Redundancy

In some cases module redundancy is requested which is based on the desire to keep multi channel modules operating when one of them fails. It is an understandable wish knowing that the exchange of a multi channel card would take down several loops.

Now, intrinsic safety does not easily lend itself to this approach because of the current and voltage limits required for this explosion protection method. Running IS channels in parallel would be contra productive to this demand.

Therefore Pepperl+Fuchs has developed high integrity single channel modules which ensure that no more than one one loop is affected in case of a failure.

Single channel devices can be operated side by side with multi channel units to arrive at economical solutions.

## Sizing Guidelines

The following considerations should be observed when designing a system.

The maximum number of slaves per RS 485 bus without repeaters is limited to 31. A mixture of single slot and dual slot modules is possible. Accessories such as screw type or wire clamp connectors for each module have to be added as required. Extension units are supplied with standard cables to connect to the base unit also linking them to the gateway.

In a running system you can

- add or remove modules without affecting others,
- connect or disconnect intrinsically safe I/O channels without affecting other channels.

At 1.5 kBit/s the maximum distance between the master and the Com Units in Zone 2 or Zone 1 is 200 m using shielded copper cable. At 187.5 kBit/s this increases to 1,000 m. Fiber optic links can stretch this to 2 km at 1.5 kBit/s.

## Bus Termination

The bus must be terminated at both ends and the last slave in the daisy chain in particular. For LB Zone 2 a Sub-D connector with a built-in end of line resistor can be used. For FB Zone 1 a dedicated end of line module is available.

## Enclosures

Safe area safety regulations must be checked and certified by cabinet builders (IP20 required). Zone 2 safety regulations will be checked and certified by Pepperl+Fuchs (Zone 2 approved IP54 required). Zone 1 safety regulations will be checked and certified by Pepperl+Fuchs (Zone 1 certified IP54 required). In flammable dust atmospheres suitable enclosures require a minimum degree of protection of IP66. Pepperl+Fuchs offers a variety of enclosure and cabinet solutions which can be tailored to the customer's needs.

## Power Consumption

Cabinets placed in an environment at 40 °C maximum may be fitted with devices to arrive at the total power consumption given in the table overleaf. The maximum power consumption is calculated on the basis that at 40 °C outside the cabinet 60 °C are reached inside.

The total consumption must include the Remote I/O plus any other consumer inside the cabinet.

## Rule of Thumb

As a worst case you can assume that analog outputs cause the most heat dissipation inside the cabinet.

Other devices send much of their power to consumers outside the cabinet so a simple rule of thumb can be established.

80 analog outputs are permitted per Remote I/O resulting in 20 modules dissipating 3 W each. So each Remote I/O will consume 60 W. Given an efficiency factor of 0.8 we arrive at a total of 75 W per slave.

Taking the most severe conditions from the table overleaf listing the permissible heat dissipation inside a cabinet, a 800 mm wide single sided cabinet allowing 384 W to be dissipated inside, will permit slaves to be installed.

Mechanically there is room for 4 slaves as a maximum for a cabinet offering front access only. Each slave is assumed to consist of a base unit and an extension unit backplane.

## Restrictions

Module power consumption can be taken from the individual data sheets.

Power supply data are not listed as the following simple rules are to be followed.

- Do not load the power supplies to maximum capacity. Always stay within the boundaries stipulated in the manual.
- Use two LB 9006 Zone 2 power supplies per backplane for non redundant systems and three for redundancy.
- Use one FB 92\*\* Zone 1 power supply per backplane and a separate one for a redundant slave.
- Use a maximum of 40 analog channels per base backplane and another 40 max in the extension unit.
- Use a maximum of 20 model 2\*02 per base backplane and another 20 max in the extension unit.
- Use boost power for 6\*10 thru 6\*15 digital outputs.
- When you have inserted the maximum numbers as indicated do not add other devices.
- Any other combination is permitted.

Be aware that Zone 1 and Zone 2 installations have special requirements. These are observed automatically by our ATEX audited factories. Panel builders would have to obtain their own certificates equivalent to our PTB 97 ATEX 1075 for Zone 1 and PF 08 CERT 1234 for Zone 2.

Technology

Basic Principles

Applications

Ex Protection  
Intrinsic Safety

Functional  
Safety







| Kind of safe area assembly                            |   | 800 x 200 x 400 mm<br>(W x H x D) | 1000 x 200 x 400 mm<br>(W x H x D) |
|---|---|-----------------------------------|------------------------------------|
| Single enclosure, free-standing on all sides          |    | 525 W                             | 616 W                              |
| First or last enclosure in a suite, free-standing     |    | 490 W                             | 581 W                              |
| Enclosure within a suite, free-standing               |    | 454 W                             | 546 W                              |
| Single enclosure for wall mounting                    |    | 454 W                             | 528 W                              |
| First or last enclosure in a suite, for wall mounting |    | 419 W                             | 493 W                              |
| Enclosure within a suite, for wall mounting           |  | 384 W                             | 458 W                              |

Table 2 Total power consumption of the enclosures depending on the kind of safe area assembly

Cabinets placed in an environment at 40 °C maximum may be fitted with devices to arrive at the total power consumption given in the table above.

The temperature inside the cabinet will then reach 60 °C.

## System Integration and Life Cycle Management

System integration has become an easy to handle field proven part of Remote I/O in process automation. This can be seen in hundreds of thousands of modules working with process control systems of all the renowned DCS vendors.

### System Partners

LB Remote I/O for Zone 2 and safe areas as well as FB Remote I/O for installation in Zone 1 are fully integrated into all major process control systems and PLCs.

### Functional Assurance

Functional assurance can be given as follows:

- written and oral agreements with system vendors offering mutual support during the plant life cycle
- close cooperation with engineering companies
- certified configuration software such as DTM or EDDL
- close cooperation with recognized, independent test laboratories such as BIS Prozesstechnik GmbH, or Dietz Automation GmbH, and IFAK System GmbH
- We maintain important process control systems in our own laboratories for continuous integration tests

### System Integration Safe and Simple

- Field proven links exist to master process control systems or PLCs.
- Standard busses work in the environment of different process control systems and are not influenced by the operating system or system release changes.
- Configure, handle, monitor, parameterize, and diagnose using the engineering environment of the process control system.
- Adhere to NE105 – secure system integration also after updates.
- Integration tests prior to updates and version changes.
- Remote I/O remain compatible after system updates.
- System continuity is supported after Remote I/O updates.
- Additional tools are available but not necessary.

## Product Life Cycle Management

For more than 10 years Pepperl+Fuchs Remote I/O have established themselves as proven in use technology. They are kept up to date through continuous development. In the chemical, petro-chemical and pharmaceutical industries, as well as in the oil and gas sectors customers expect plants to operate reliably for 10 to 15 years after commissioning. This is made possible through the following activities.

- Life Cycle contracts with important system vendors e. g. ABB and others.
- Life Cycle service agreements on a project by project basis.
- Pepperl+Fuchs delivers compatible products during the plant Life Cycle.
- customer support from advice to engineering, from commissioning assistance to service
- contracts and agreements with system vendors ensure interoperability
- continuous development of compatible products to make sure they satisfy the latest standards and regulations

Pepperl+Fuchs is an active member of international organizations such as PNO, FDT Group, Fieldbus Foundation, and HART Communication Foundation. We are also represented on the board of the **PACT<sup>ware</sup>**™ consortium.

### International Service

Pepperl+Fuchs sports a worldwide presence of around 4,000 employees. Trained service engineers and advisors are at hand in all important markets.

- local service worldwide
- commissioning assistance
- fast remote service using PC Anywhere
- telephone assistance
- personal on site service
- training as required

## PACTware™ – One Configuration Tool for all Instruments



PACTware™

Since the introduction of intelligent field devices in the 1980s the need for interoperability has grown. We have come a long way from the individual field-operated handheld communicator to today's universal tools.

PACTware™ is a manufacturer and fieldbus-independent software for handling field instruments. It represents an open platform in which individual manufacturers can integrate the operation of their field instruments. Contrary to the idea of describing the instruments via a text file (Device Description), PACTware™ uses a standardized interface for instrument operation between the frame program and the individual software modules. This allows modern and user-friendly adjustment concepts to be realized.

### Optimum Configuration Functions

In the PACTware™ concept, optimum instrument adjustment takes top priority. The uniform interface enables the use of the best possible configuration concepts: optimized to fulfil user requirements and detached from the inflexible restrictions of superordinate software, PACTware™ distinguishes between software modules for actual instrument configuration and parameterization and modules required for communication. This allows data transfer to be carried out through any type of communication

PACTware™ supports all the standard communication protocols. At the same time, its structures allow the integration of future standards.

### Versatile

Each plant is different so a versatile tool is ideal. PACTware™ can be implemented in many different places in a plant: from the central engineering station to on-site adjustment in the field.

For the first time, it is possible to carry out parameter settings and configuration of all the field instruments of all the manufacturers using any field bus of a plant with only one engineering tool.

## PACTware™ – Based on FDT and DTM Technology

PACTware™ employs the FDT/DTM concept. This technology specifies the exchange of data between the system level and the field instruments.

### Field Device Tool (FDT)



FDT is the name of an interface specification. The easiest way to explain the technology is by using an example from the office world: if a new device such as a printer is installed under

Windows, it is done by installing a suitable driver. This printer driver (device driver) is device and manufacturer-specific and comes with the printer. The device provides its own user interface. Communication between the operating system and the printer takes place via predefined routines

### Plug & Play in Automation

The FDT concept transfers this idea to the world of automation: each communicating field instrument has an electronic device description that can be integrated into the world of the system. That is, into the configuration and adjustment tools of a system environment, as well as into the stand-alone PACTware™ tool.

### No new Description Language

The concept centers round the fact that no new description language needed to be defined. Instead the interface between the tool and the description object of an instrument was standardized. This makes the concept independent from the actual (field bus) communication protocol itself.

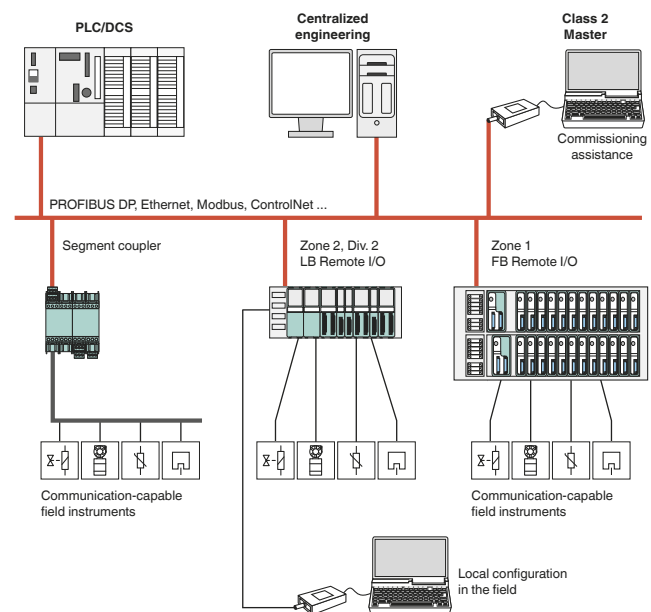

Figure 9 PACTware™ operation on a workstation in the control room or on a laptop in the field

Edition 912907 (US) / 220718 (EU) 06/2011

Technology  
Basic Principles  
Applications  
Ex Protection  
Intrinsic Safety  
Functional Safety

## Device Type Manager (DTM)

Like the printer driver in the office world, the field instrument brings its own driver, including the user interface, into the FDT world. This driver is called Device Type Manager, in short, DTM. It contains all the data and functions of the field instrument. A DTM can cover just one instrument type, or in some cases a complete family of instruments.

## Unlimited Possibilities

Whereas a normal Device Description (DD) can only offer a fairly inflexible description of instrument functionality, a DTM has almost no limitations with regard to presentation and user guidance. The configuration of all available instrument functions, perfectly adapted to the user's requirements, is thus made possible. Furthermore DTM technology allows the same instrument configuration procedures to be used in any FDT environment. It always presents itself with the same look and feel.

## Quick and Easy

FDT frames are supplied by many vendors with system suppliers offering their own. **PACT<sub>ware</sub>**™ on the other hand is an open access FDT frame available to anybody. The handling of **PACT<sub>ware</sub>**™ is really easy. To begin with, all the instrument DTMs of a plant, including communication drivers, are assembled into one project. The corresponding instruments are simply fetched from a device catalogue via drag-and-drop and inserted into the project. Once this is done, the structure of the system is transparent and clearly defined.

From here on, each individual instrument and communication component can be directly accessed to perform the following tasks:

- to adapt the configuration
- to modify individual parameters
- to simulate individual functions
- to get a detailed, meaningful diagnosis
- to prepare documentation

And all of this is manufacturer- and communication-independent. Needless to say, subsequent modifications and extensions of the structure can be carried out at any time.

## Proven, Readily Available Technology

As a stand-alone tool **PACT<sub>ware</sub>**™ and the corresponding DTMs have already been used successfully for many years. In spite of that, appropriate DTMs for every instrument of every supplier are not always available. However, a so-called DD compiler, now makes it possible to automatically generate a simple, but fully functional DTM from the device description (DD) of a HART instrument. Conversion tools for PROFIBUS and FF instrument device descriptions are in preparation. This guarantees wide availability within a short time.

## Configuration

**PACT<sub>ware</sub>**™ allows the configuration of a complete system. In the process, an online connection is not necessary. Thus, for example, topology planning as well as structuring and configuration of the implemented system components can be carried out in offline mode.

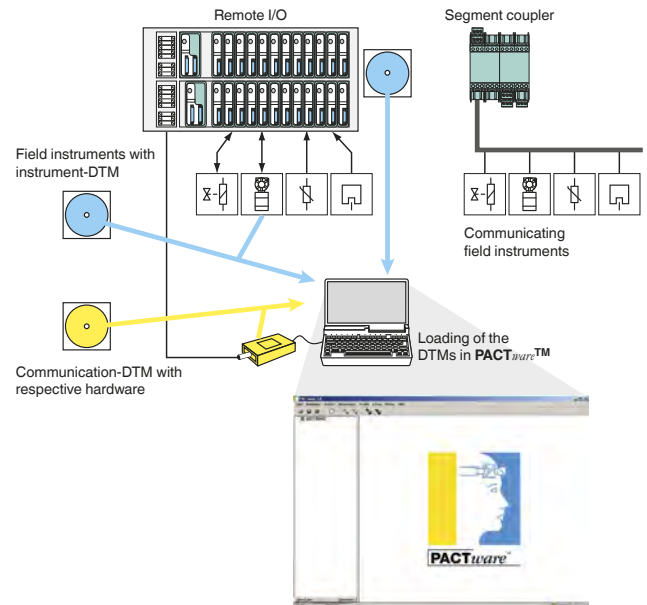

Figure 10 DTMs come with the field devices to work within the FDT frame

## Parameter Settings

Instruments and systems are parameterized with **PACT<sub>ware</sub>**™ using point-to-point communication or employing a bus system. User friendliness has top priority embracing easy installation without complex topology planning. Fast readout of device information as well as reliable downloads of modified settings into an instrument are guaranteed. This is typically carried out in the workshop, from the control room or in the field.

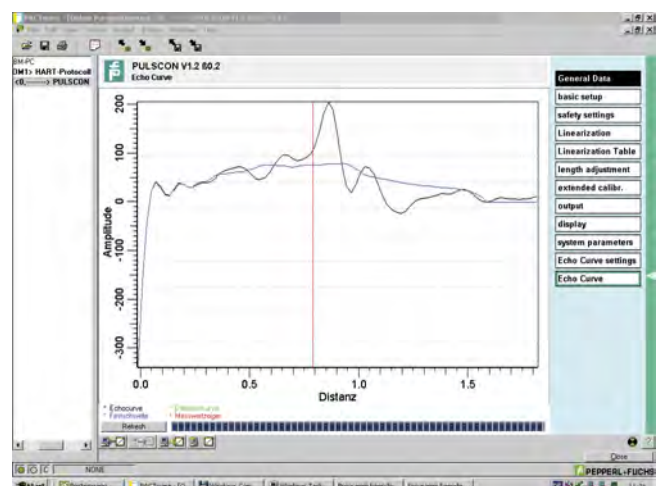

Figure 11 Online Process Data Analysis using DTMs

## Simulation

During commissioning the signal flow within an application can be checked by simulating a certain process value. Signals can thus be traced over different measurement points and faults corrected at an early stage.

## Diagnostics

Suitable tools are available in the DTMs in **PACT<sub>ware</sub>**<sup>TM</sup> for the analysis of faults in the system or in the field instruments. For example, short-term faults can be detected by means of the graphical presentation of measured values. In order to realize long-term observation of data, measured values can be recorded over an unlimited period of time.

## Documentation

An overview of the project as well as the set values of individual instruments can be conveniently printed out with **PACT<sub>ware</sub>**<sup>TM</sup>. Furthermore, all necessary information such as device description, manufacturer identification, order number, serial number and firmware version are available in the DTM. Thus time consuming searches for up-to-date documentation are a thing of the past.

## PACT<sub>ware</sub><sup>TM</sup> Advantages at a Glance

**PACT<sub>ware</sub>**<sup>TM</sup> is a manufacturer- and field bus-independent software for the operation of field instruments. It allows you to configure widely differing instruments in any automation environment with only one software tool.

### PACT<sub>ware</sub><sup>TM</sup>

- fits any automation environment and simplifies engineering and commissioning
- is the platform for all DTMs to the FDT standard
- allows the configuration of all field instruments including Remote I/O via any communication structure
- supports the complete functionality of the field instruments
- unifies the instrument world
- is prepared for new standards, such as Ethernet
- is free of charge and continues to grow

## EDDL Alternative

Similar to the FDT/DTM concept an Electronic Device Description Language (EDDL) technology is used by major manufacturers to describe the information that is accessible in digital devices. EDDLs are mere text files describing the parameters of over 15 million devices that are currently installed in the process industry. The technology is employed by the major process control systems and maintenance tool suppliers to support device diagnostics and calibration.

Originally only used via handheld communicators these were compatible only with devices from the same manufacturer. The need for interoperability between devices from different manufacturers became the main driving force for the EDDL standard.

Like DTMs the electronic device descriptions simplify commissioning allowing the user to assign tags and device addresses. Today this is possible from a central location via a bus. It includes monitoring, identifying, and reading device ID, serial numbers, versions etc. It also offers access to general information such as materials of constructions etc. plus dynamic monitoring of device internal parameters and logic. Diagnostics include simple sensor failures, loss of supply air, memory failures etc. plus advanced performance analysis such as valve signature, step response, hysteresis etc. Operational statistics such as number of valve strokes, total travel, and power cycles etc. is also available.

Just like DTMs, EDDL allow configuration and setup of devices including parameterization such as ranging as well as advanced setup as in radar level transmitter echo tuning. Loop testing and calibration trim can also be done.

Data can be stored in databases along with service notes and much more. Device management software allows logging of calibration, inspection, and service etc. and is stored in the audit trail.

Advanced EDDL technology not only lists all the parameters but also offers graphic tools for more visual information.

Pepperl+Fuchs Remote I/O subscribe to both technologies FDT/DTM as well as EDDL to offer the end user the widest possible choice.

For details refer to NAMUR NE105.

## Asset Management

In addition to the features offered by **PACT<sub>ware</sub>**<sup>TM</sup> some commercially available FDT frames or EDDL interpreters offer asset management facilities. The functionality often includes the monitoring of devices like flow meters, analyzers, actuators, and control valves. It detects faults and sometimes even recommends corrective actions.

Asset management is the key to extending service intervals thus reducing operating costs.

Some asset management packages can assess and prioritize faults, so that major problems get attention first.

As FDT frames can be installed on a separate PC or workstation they do not have to be part of the process control system. This may also be useful for some plant operators who want to manage production assets but do not want to install a full distributed control system. Also see "Asset Management" section.

## HART Communication

Many legacy sites and certainly all green field installations have discovered the benefits of HART. The potential of this technology has often lain dormant for many years. It now reaches new spheres and opens up possibilities which come as a free bonus with Remote I/O installations.

Modern process instrumentation makes use of digital data transmission to interface the plant level of sensors and actuators with the process control system. Remote I/O in particular now in its second generation has a decade of field experience offering simple means to help with everyday maintenance issues. This alleviates the concern of many plant operators that familiar signals would disappear. They do not want to have to employ highly trained qualified engineers seeing to simple service tasks.

Although the digital fieldbus offers a multitude of attractive features many sites are quite happy with traditional point to point instrumentation or even Remote I/O when control room space is limited or other known Remote I/O advantages are brought into the equation. Here conventional multimeters can be used for many tasks even down to a check of the bus line. It is possible to employ Ohmmeters or current and voltage meters to detect multiple bus terminations as well as unterminated bus lines while measuring from the control room. This also applies to hazardous area applications with PROFIBUS or MODBUS using standard RS 485 hardware with increased safety connections. In this context HART communications offer added benefits as the following paragraphs will show.

### Basics of HART Communications

HART communication is a long established principle which is now supported by almost all 20 mA field devices. In many cases field devices installed years ago were equipped with HART features but never used to their full potential. Basically HART makes use of the frequency shift keying principle to superimpose digital information on the standard 4 mA... 20 mA current loop (Figure 12).

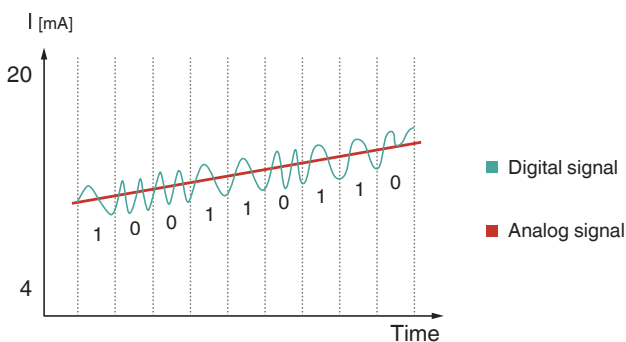

Figure 12 HART modulation of a 20 mA Signal

A logical 1 is represented by a frequency of 1200 Hz while a frequency of 2200 Hz equals logical 0. The pulse amplitude averages out to zero as not to falsify the measured signal.

The information contained in the HART signal ranges from scaling parameters for the beginning and end of range values to extensive additional data showing status, secondary variables, and preventive maintenance information.

**Note: Be aware that fast analog to digital converters would easily pick up the HART signal resulting in erroneous measurements.**

### HART Handheld Devices

It used to be common practice to employ handheld communicators to parameterize each HART field device individually (Figure 13).

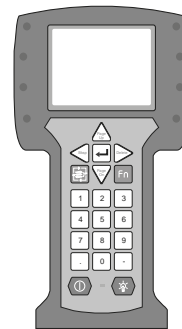

Figure 13 Handheld HART Communicator

These handheld devices give access to all the features the corresponding field instrument can offer. It has to be connected to the 20 mA current loop.



Figure 14 Applying the Handheld Communicator

The next generation saw point to point K-System isolators employing a HART multiplexer connected to a laptop via a RS 485 link. This allows you to reach each field device from a central operating station in the control room.

The more modern approach is to make use of the built-in HART communication feature of Remote I/O. Again there is a central access point in the control room but now it is even possible to address all the HART devices from the process control system using embedded communication technologies.



## HART Bus Communications

### HART via PROFIBUS

PROFIBUS DP offers a fast communications channel for cyclic data exchange between the control system and the sensors and actuators in the field. The protocol was later extended to deal with asynchronous information fitted into the time gaps between synchronous telegrams. This became PROFIBUS DP V1.

The extended protocol not only handles device parameters and configuration data of PROFIBUS slaves but it can also carry HART signals. Some process control systems or PLCs feature PROFIBUS DP V1 master cards. Other DCS vendors do not support asynchronous data and are restricted to PROFIBUS DP. In both cases HART communication is possible. While the former offer HART from the DCS or PLC operator station the latter will have to employ a class 2 PROFIBUS master.

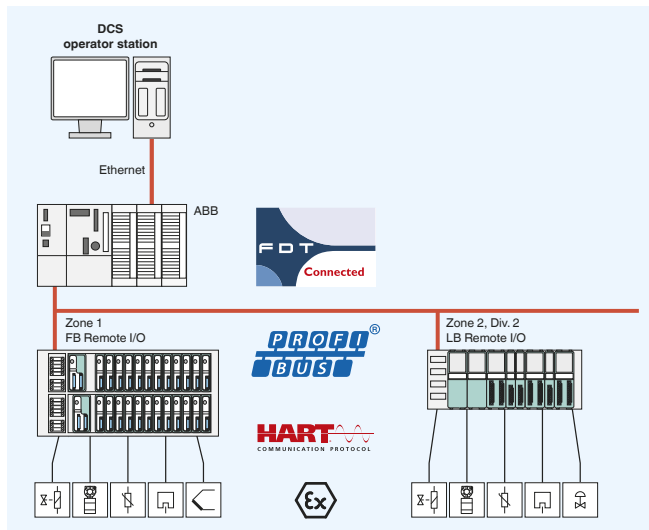

Figure 15 HART through ABB FDT/DTM technologies (Symphony and Freelance)

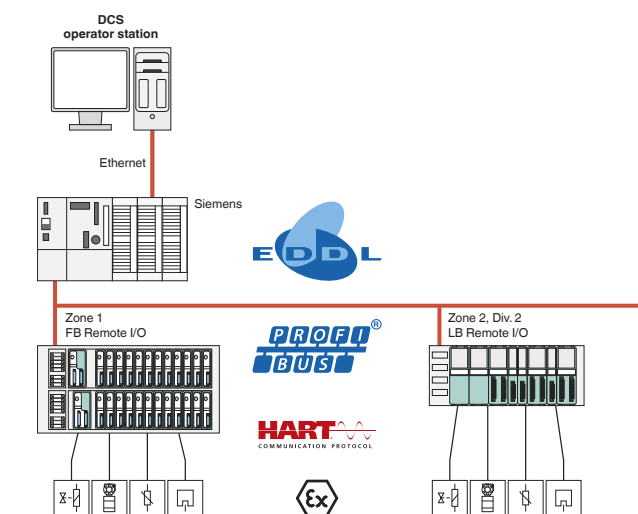

Figure 16 HART through Siemens EDDL technology (S7/400)

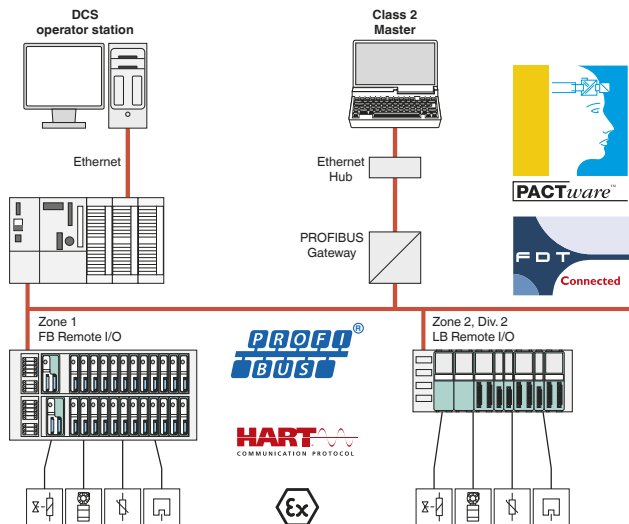

Figure 17 HART using class 2 master for any DCS

The figures show how HART commands are exchanged with field devices connected to Remote I/O. Figure 15 see ABB making use of FDT/DTM technologies to offer full HART compatibility. The same applies to Siemens (Figure 16) where the EDDL technology replaces the FDT concept. In both cases the HART features are available from the control system's own engineering tool and operator station.

In contrast Figure 17 shows a constellation which will work with any DCS or PLC irrespective of the master's capability to support PROFIBUS DP V1 or FDT/DTM or EDDL technologies.

The class 2 master is connected to the same PROFIBUS which the DCS or PLC are using for regular data exchange. The class 2 master can be any laptop or PC with a PROFIBUS interface card. This can be an integral part of the laptop or an external device as depicted in Figure 17. Off-the-shelf external class 2 PROFIBUS masters are also available in the form of Ethernet to PROFIBUS gateways.

The class 2 master does not interfere with the DCS or PLC PROFIBUS communication in any way. Class 2 PC or laptop software updates also do not have adverse effects on the bus's main function.

The class 2 master can make use of the following software packages to offer HART communications.

#### PACTware™

This software package employs the FDT/DTM concept. The basic functions are available free of charge. These also include configuring and parameterizing a Remote I/O slave as well as diagnostic functions. A licence fee becomes payable only if the more sophisticated project features are required which allow the user to build project trees rather than simply looking at each slave individually. PACTware™ is normally used as a class 2 master on a separate workstation.

### FieldCare

This software package employs the FDT/DTM concept in a similar way to **PACT<sup>ware</sup>**<sup>™</sup>. It also includes configuring and parameterizing a Remote I/O slave as well as diagnostic functions. It is licenced by Endress+Hauser. It is normally used as a class 2 master on a separate workstation.

### PDM

This software package employs the EDDL concept. This also includes configuring and parameterizing a Remote I/O slave as well as diagnostic functions. It is licenced by Siemens. It can form an integral part of the S7 or PCS7 system and route HART signals through the PROFIBUS master. It can also act as a class 2 master on a separate workstation.

### AMS

This software package employs the EDDL concept. It only offers HART functionality and does not include configuring and parameterizing a Remote I/O slave nor diagnostic functions other than for the HART transmitters. It is licenced by Emerson. It is normally used as a class 2 master on a separate workstation.

### HART and MODBUS

Unlike PROFIBUS the MODBUS protocol does not offer provisions for asynchronous HART communications to be transported via the same bus. MODBUS Remote I/O therefore require a service bus in order to support HART.

### HART via Ethernet

Unlike MODBUS RTU the Pepperl+Fuchs MODBUS TCP Ethernet Remote I/O supports HART via Ethernet. Similar to the PROFIBUS class 2 principle a stand-alone HART master can be connected to the Ethernet. This can be a laptop or PC running **PACT<sup>ware</sup>**<sup>™</sup> to support all the same features that this free software package offers with PROFIBUS applications.

### HART via Service Bus

Whenever neither of the above services are available LB/FB Remote I/O can make use of HART communications via the service bus. The service bus offers a separate RS 485 hardware connection to address Remote I/O slaves. It not only features HART but is also capable of acting as a fully fledged commissioning and service tool.

The service bus can be connected to a laptop or PC running **PACT<sup>ware</sup>**<sup>™</sup> to support all the same features that this free software package offers with PROFIBUS applications. A simple USB to RS 485 converter is required to accomplish the hardware adaptation. Please ask Pepperl+Fuchs for details.

### HART and FOUNDATION Fieldbus

FOUNDATION Fieldbus offers intelligent communications with field devices that go beyond the scope of HART. Since there is no standard to accommodate HART protocols on FOUNDATION Fieldbus traditional HART transmitters can only make use of the 20 mA signal when connected to the FF Modular I/O. Handheld communicators then give access to the device parameters. The 250 Ω communication resistance is incorporated in the transmitter power supply for the FF Modular I/O modules.

The Com Unit/Gateway is open for HART communication via the service bus. The I/O modules receive the HART telegrams from a communication unit (LB 8110 or FB 8210).

### Addressing HART Transmitters

Each field transmitter can easily be assigned to a Remote I/O slot during the engineering phase of a project. Activating the HART channel in the topology plan will be sufficient. Some commercially available software packages have learning functions that automate a scan of all the field devices as long as the HART channel of a module has been enabled.



## Response Times

### Cyclic Data Response Times

The response time of analog input cards of any Remote I/O largely depends on the scan rate of the bus. The fastest PROFIBUS (1.5 MBd) normally addresses the connected slaves about once every 20 ms. This is due to the internal processing time of the process control system (DCS) which has to deal with many bus lines and not just an individual slave.

The Pepperl+Fuchs communication module contains a dual port memory which scans the I/O modules internally once every 6.5 ms. So all input/output data is refreshed at that rate. Digital I/O therefore respond very quickly indeed. Your external scan cycle therefore does not have to wait for conversion times within the Pepperl+Fuchs system since all data is offered via direct memory access.

Furthermore most Remote I/O manufacturers use analog/digital converters in their analog input devices which work at around 20 ms ... 100 ms conversion time. This will help to filter out 50 Hz noise. There is also a 60 Hz setting.

At Pepperl+Fuchs we use a 20 ms conversion time. This conversion takes place in each module independent from other scan cycles. It will then take the Pepperl+Fuchs communication unit (the gateway) about 6.5 ms to store this data in memory for the DCS system to collect. After that it depends on the DCS scan rate to determine how soon the data will arrive in the master (see above). The same applies to analog outputs only in reverse.

Analog inputs also feature a filter to eliminate signal changes faster than 1 % per second (noise and interference). The filter can be activated or deactivated.

Under worst case conditions the conversion time will be extended on the basis that having missed a signal change on the first conversion cycle a second conversion cycle becomes necessary. For analog values the timings also include the settling time for a 10 % ... 90 % change to reach its correct value. Line fault detection can also slow down the timing.

### HART Response Times

As mentioned in previous paragraphs the HART signal is superimposed on the analog signal. The response time of the measured analog value is therefore much faster than that of the more accurate digital HART value. It can take several seconds before the HART value follows the corresponding analog value.

This is quite acceptable with process variables that only change slowly. So while these slow signals can be used for control fast moving signals do not normally lend themselves to be employed for this purpose.

## System Integration

System vendors employ different methods to integrate HART. LB Remote I/O being electronically identical with FB Remote I/O has successfully undergone integration tests with ABB and Siemens offering HART communications routed through the PROFIBUS master of the DCS. ABB makes use of the FDT/DTM principle while Siemens use their PDM with approved Pepperl+Fuchs EDDL files. LB/FB Remote I/O are fully compatible with both of these.

A class 2 master can be used for any other DCS vendor including those who do not offer PROFIBUS DP V1.

## Conclusion and Summary

To summarize we can state that HART communications are increasingly being used around the process industries. There is a large installed base of HART transmitters which can now be employed to fulfil new tasks. Their full potential lay dormant for many years and can now help to improve efficiency and reduce maintenance costs. HART via Remote I/O is compatible with all major DCS and PLC systems which have PROFIBUS, MODBUS, FOUNDATION Fieldbus or Ethernet interfaces.

Technology

Basic Principles

Applications

Ex Protection  
Intrinsic Safety

Functional  
Safety

Edition 912907 (US) / 220718 (EU) 06/2011

# Applications and Practical Solutions

## Standard and Customized Solutions

### Complete Solutions – Fast Installations to Suit Individual Needs

Pepperl+Fuchs products are used throughout the world involving industrial, hazardous, and corrosive environments. Closely cooperating with our customers our project engineers will offer complete solutions in a variety of panels and enclosures. Customized and standard solutions are equally competitively priced and ensure the fastest possible installation on site.

#### Solution Provider

Expert knowledge in applying all kinds of explosion protection methods ensures that we can help you find the best possible solution for your application.

Our field sales engineers are equipped with the necessary tools to quickly guide you through a wide variety of options that we can offer you to arrive at the best possible technical solution at a competitive price.

Our project engineers will accompany you through all the phases of your project from quoting to ordering to factory acceptance tests or even commissioning.

#### Hazardous Area Questions Answered

Pepperl+Fuchs employs standards experts to deal with explosion protection in all areas, covering a multitude of techniques. We are members of various international committees and standards groups. Thus we are at the forefront of the latest developments in state of the art technologies.

You can be sure to find good advice in the field of explosion protection. You can rely on cabinets and enclosures designed and manufactured by Pepperl+Fuchs to meet the relevant standards, rules, and regulations.

We supply documents and instruction manuals to help your staff install the equipment correctly. This goes as far as checking the permitted heat dissipation inside enclosures and cabinets for your application.

That way we strive to make hazardous area installations as easy for you as possible so that you can benefit from the advantages they can offer you.

This applies equally to end users, engineering companies, contractors, EPCs, or indeed system builders themselves.

### Explosion Protection Made Easy

Remote I/O represents an easy to use technology in that field instrumentation can be handled in the traditional way using multimeters and long established fault finding methods. Remote I/O employ various explosion protection methods in order to simplify matters for the end user.

So basically intrinsically safe loop proofing remains the same as for a traditional installation. Changes in instrumentation at a later stage are as easy as ever. Should you need extra power in the hazardous area even that can be accommodated using our Remote I/O.

### Combining Fieldbus and Remote I/O

Where necessary Pepperl+Fuchs can offer a combination of point to point interfaces with Remote I/O such as in SIL3 applications.

We also assist you in designing fieldbus systems in combination with Remote I/O when fieldbus related instruments need to be employed alongside traditional signals from switches, solenoids, or temperature sensors.

All this has been proven in use over many years.

### Safe Area Installation Advantages

Installing Remote I/O signal conditioning equipment in the safe area has the following advantages:

- within easy reach of the operator
- quick and easy service within walking distance
- fast commissioning
- module hot swap
- configuring and parameterizing field devices via the bus
- stretching service intervals through regular monitoring of the relevant field device parameters
- use of HART secondary variables to save on measuring points

However, long cable runs and control room space restrictions may favour hazardous area installations.

### Zone 2, Div.2 Installation Advantages

Installing Remote I/O signal conditioning equipment in Zone 2 or Div.2 hazardous areas has the following advantages:

- reduced wiring and reduced numbers of connections
- faster commissioning
- much reduced space requirements in the control room
- quick and easy service response via the bus
- module hot swap under normal operating conditions
- configuring and parameterizing field devices
- stretching service intervals through regular monitoring of the relevant field device parameters
- use of HART secondary variables to save on measuring points

## Zone 1 Installation Advantages

Installing Remote I/O signal conditioning equipment in Zone 1 hazardous areas has the following advantages:

- offers all the advantages listed for Zone 2 plus
- further reduced wiring and further reduced numbers of connections
- module hot swap under hazardous conditions

## Purge Advantages

In some cases it may be desirable to install safe area equipment in Zone 1 hazardous areas using purge. This has the following advantages:

- permits the use of low cost safe area devices
- permits devices from various manufacturers to be combined in one enclosure
- controllers and IS interfaces can share the same cabinet

However, module hot swap is not possible with a purge enclosure.

## High Reliability

Where necessary single channel I/O modules and redundancy offer an extra reliable system. The features need not be employed from the start but can be added when required.

## Sound Project Support

Our project engineers will also help you select the correct bus protocol from PROFIBUS to MODBUS to FOUNDATION Fieldbus or Ethernet. These represent industry standards which are open to all DCS, PLC, and SCADA systems.

Migration from one to the other is possible without too much ado giving you peace of mind.

Furthermore we help you observe hazardous area restrictions where components need manufacturer declarations for use in Zone 2 or certificates for Zone 1.

The documentation also reminds you that modifications or extensions have to be made in accordance with possible restrictions.

## Cabinets and Enclosures

Our project engineers will also optimize the subunit for your application. It will fit the location perfectly and contain not only the Remote I/O but also other components the application requires. It can be adapted to company standards to simplify on-site installation, handling and maintenance. Yet it is adaptable to future changes within the guidelines we provide.

Cabinets and enclosures may contain additional equipment to arrive at a complete solution. Pepperl+Fuchs has built thousands of "boxes" containing Remote I/O with valve banks or hazardous area replaceable fuses.

We have combined intrinsically safe loops and increased safety loops in the same housing. We have supplied cabinets with marshalling or without. We have accommodated fiber optic links and redundancy. There were Zone 1 mounted power supplies for relay circuits or separately powered field devices. The pictures present but a few examples.

Need we say more?

## Control Room Installation

Control cabinet with process control system

- space for 3 Remote I/O stations with 3 x 46 slots
- 240 analog signals or a combination of these.
- dimensions: 800 x 2000 x 400 mm (31.5 x 78.7 x 15.7 in)



Figure 1 Control room installation

## Zone 2/Zone 22/Div. 2 Installation

Standard stainless steel LB Remote I/O enclosure

- 80 analog I/O or 184 digital I/O or a combination of these
- dimensions: 800 x 800 x 300 mm (31.5 x 31.5 x 11.8 in)

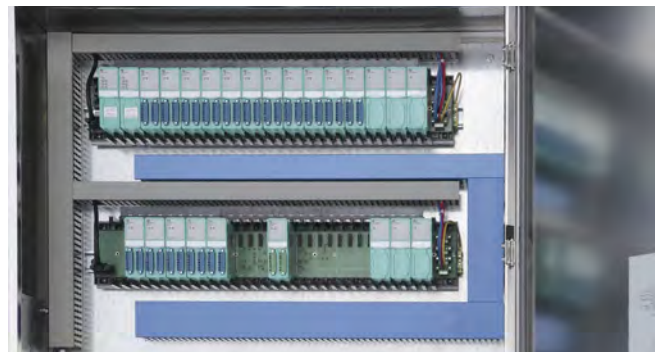

Figure 2 Stainless steel LB Remote I/O enclosure

### Zone 1/Zone 21 Installation

Customized stainless steel FB Remote I/O enclosure with added valve banks, marshalling terminals and replaceable power fuses

- 80 analog I/O or 196 digital I/O or a combination of these
- dimensions: 800 x 1000 x 300 mm (31.5 x 39.4 x 11.8 in).



Figure 3 Stainless steel FB Remote I/O enclosure

### Zone 1/Zone 21 Installation

Customized Polyester (GRP) FB Remote I/O enclosure with increased safety wiring to replaceable fuses

- flanged enclosures made up of standard 544 x 271 x 210 mm (21.4 x 10.7 x 8.3 in) boxes.



Figure 4 Polyester (GRP) FB Remote I/O enclosure

### Network Based Process Visualization

Pepperl+Fuchs VisuNet is the world's first Zone 1 HMI platform for the process industry to communicate via Ethernet TCP/IP network structures and eliminates proprietary connections. VisuNet is compatible with all established PC-based distributed control systems (DCS).

The distance between monitor, mouse and keyboard located in the hazardous area and the Host-PC in the safe area can be up to 2 km. It can be used to control plant operations via Remote I/O. VisuNet meets even the toughest requirements on robustness, safety and functionality.



Figure 5 VisuNet solutions

### Certificates

Pepperl+Fuchs equipment is supplied with a wide range of certificates from ATEX to IECEx to UL and many others for gas hazardous areas Zone 0, Zone 1, Zone 2, and Div. 1, Div. 2 or dust hazards in Zone 21, Zone 22, and Class III. In addition we offer FAT (Factory Acceptance Tests) and GAMP procedures.



## Global Purge Solutions

Applications requiring safe area equipment to be mounted in hazardous areas can be dealt with using Bebcos EPS Purge and Pressurization systems. These offer a safe and economical approach to installing electrical equipment in hazardous locations. They purge and pressurize the protected enclosure and then maintain pressure within the enclosure. This reduces the classification within the protected enclosure from a Div. 1/Zone 1/21 to Div. 2/Zone 2/22 or general-purpose area.

- By creating a safe area inside an enclosure, general-purpose equipment can be used in hazardous (classified) areas.
- Flammable gas collected inside the enclosure is removed and the accumulation of gases or ignitable dust within the pressurized enclosure is prevented.
- Europe, Asia, or North America –we have a universal purge solution for all your applications!

### 6000 Series: Type X/Ex px Purge Example

Pepperl+Fuchs' 6000 series is the most advanced system on the market! It has a 316L stainless steel, type 4X, IP66 housing that contains the controller, pneumatics, electrical I/O, and programming interface.

The programming screen allows easy setup and operation and lets the user program the system according to the requirements of the application. The screen also displays information such as flow, pressure, and system status. The pressure and flow feedback is provided to the control unit by the vent. Certified for use in North America, Europe, and Asia, this is your single solution for all your purge and pressurization applications.

- DEMKO, ATEX, UL, cULus, IECEx, IEC 61508, SIL2
- Enclosure volume up to 250 ft<sup>3</sup> (7.08 m<sup>3</sup>)
- Completely automatic
- Single unit certified for gas and dust atmospheres
- Vent can be mounted in any orientation
- Component kit available for easy integration of an existing enclosure



Figure 6 Purge solutions

## Remote I/O Isolated Barriers

Intrinsic safety barriers are the core of Pepperl+Fuchs' product portfolio. We offer the widest selection of devices for protection of electrical signals located in hazardous areas. This guide presents common hazardous area applications involving intrinsic safety barriers to assist in selecting the correct Remote I/O barrier application.

Their unique design allows simple expansion with no additional wires, and can be easily designed for redundant power and bus configurations. The LB- and FB-Systems ensure conformity to international standards.

At Pepperl+Fuchs, we build and support quality products that meet the demands of our customers and take intrinsic safety into the 21st century.

The barriers built into Remote I/O modules shown in the following diagrams are completely isolated from ground. In addition to the galvanic isolation from the bus and the power supply some even feature channel isolation while others offer group isolation.

The units are provided with amplifiers that transfer discrete (digital) or analog signals to and from a hazardous area to a safe area via a bus.

### Digital Input

A NAMUR proximity sensor is a device that has well-defined, electrical characteristics that can be interpreted by a switch isolator to indicate the presence or absence of particular material in front of the face of a sensor. Since it has very low energy consumption and storage, a NAMUR sensor is suitable for hazardous area applications. A mechanical contact or switch can also be used in conjunction with an isolated barrier and can be installed with parallel- and series-connected resistors to simulate the operation of a NAMUR sensor. Line fault detection (lead breakage/short circuit monitoring) is available on most switch isolator barriers.

The proximity sensor or mechanical contact will initiate a safe area control mechanism in the barrier and send the information to the gateway or Com Unit which in turn communicates with the master DCS or PLC via a bus.

The following illustrations show several of the possible configurations. The examples illustrated cannot claim to cover every aspect. Only a small number of possible solutions can be shown. Many additional options including special features are available.

The illustration shows a typical application involving a switch isolator. The product shown is powered via the backplane. This barrier can be connected to either a NAMUR proximity sensor, optocoupler or dry contact.

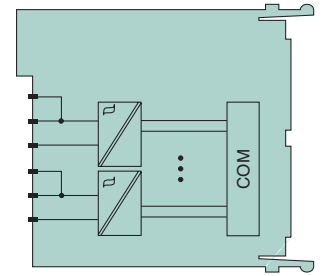
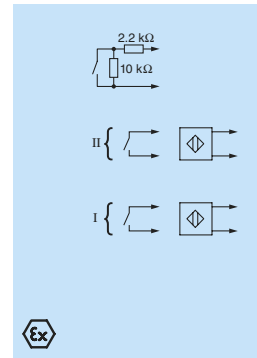

|       | 2 channels |         | 8 channels |         |
|-------|------------|---------|------------|---------|
|       | Zone 2     | Zone 1  | Zone 2     | Zone 1  |
| Ex ia | LB 1101    | FB 1201 | LB 1108    | FB 1208 |
| Ex ic | LB 1001    |         | LB 1008    |         |
| Ex e  |            | FB 1301 |            | FB 1308 |

Figure 7 Example digital input

### Frequency/Pulse Input

Frequency measurements are used in rotating machinery, in some flow meters, and for other process variables. Remote I/O frequency input modules can measure these provided they offer passive signals from NAMUR type sensors, opto couplers or dry contacts. Direction of rotation can be detected at the same time.

Similarly pulse inputs can be registered to integrate flow or other values in dosing applications using the up/down counter setting of the device.

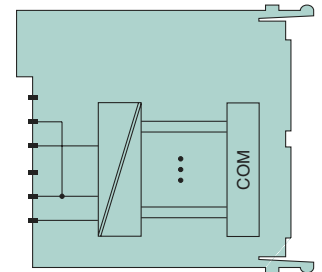
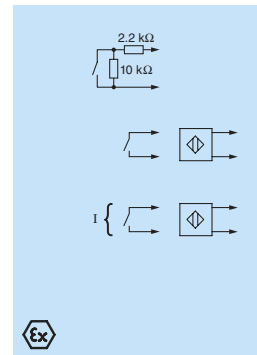

|       | 15 kHz    |           | 400 Hz    |           |
|-------|-----------|-----------|-----------|-----------|
|       | Zone 2    | Zone 1    | Zone 2    | Zone 1    |
| Ex ia | LB 1103 A | FB 1203 B | LB 1103 C | FB 1203 C |
| Ex ic | LB 1003 A |           | LB 1003 C |           |
| Ex e  |           | FB 1303 B |           |           |

Figure 8 Example frequency input

### Solenoids, LEDs, and Alarms

Many of the machine and process automation applications can range from the most basic on/off function to extremely complex sequencing.

When the process involves linear or rotary motion, or on/off flow control, solenoids are among the most common devices. Where simple status or alarm indication must be seen or heard, LEDs and audible alarms or sounders are employed.

The figure below illustrates the standard method of driving solenoids, LED clusters and audible/visual alarms in a hazardous location.

As the drive requirements for solenoids differ considerably there are a variety of solenoid driver modules available to suit each application. These range from 8-channel low power versions to 4-channel drivers with boost power. There is even a 1-channel output device with digital inputs to monitor valve position feedback.

Indicating LEDs or sounders can also be driven from these digital output devices. Make sure to switch off the line fault detection since this sends out a very short test pulse every so often to check for open or short circuits. With line fault detection On LEDs would start flashing and sounders might give a murmur with every test pulse.

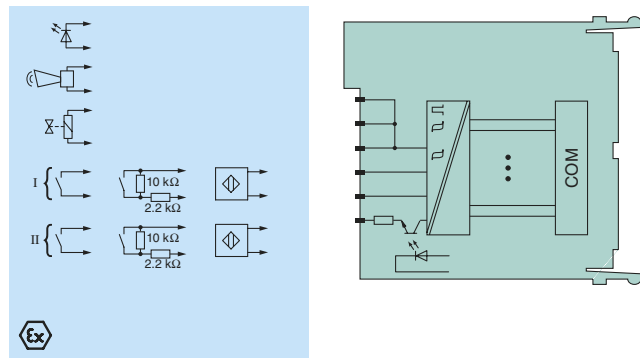

|       | 1 channel and 2 inputs |         | 4 channels |         |
|-------|------------------------|---------|------------|---------|
|       | Zone 2                 | Zone 1  | Zone 2     | Zone 1  |
| Ex ia | LB 21**                | FB 22** | LB 61**    | FB 62** |
| Ex ic | LB 2002                |         | LB 6010    |         |

\* Variants to cover different values

Figure 9 Example digital output

### Transmitters

Transmitters are used to generate an electrical 0/4 mA ... 20 mA signal proportional to a measured value such as temperature, pressure, differential pressure, level or flow. These devices are available as 2-wire, 3-wire, or 4-wire transmitters. Loop powered 2-wire transmitters are connected to transmitter power supplies which provide them with energy while at the same time converting the measured 4 mA ... 20 mA current into digital form for bus communications.

Some transmitter power supplies may also be used to feed 3-wire transmitters with up to 23 mA. In this case the third wire carries the active return current of either 4 mA ... 20 mA or 0 mA ... 20 mA.

Line fault detection for shorts and open circuits is possible for 4 mA ... 20 mA signals.

Some transmitters require more power than a transmitter power supply can provide. They are then separately powered and offer an active signal of either 4 mA ... 20 mA or 0 mA ... 20 mA. So two wires will go to their separate power source while the other two wire are connected to the analog input of the Remote I/O.

Many of these transmitters feature HART communications providing additional information vital to the process. The related digital signal is superimposed on the standard measurement signal. These transmitters can be configured via the loop and in some cases their secondary variables can be used to save on additional measuring equipment. By way of example a flow transmitter's primary value will be represented in the 4 mA ... 20 mA current signal while the temperature of the medium can be addressed by the HART protocol.

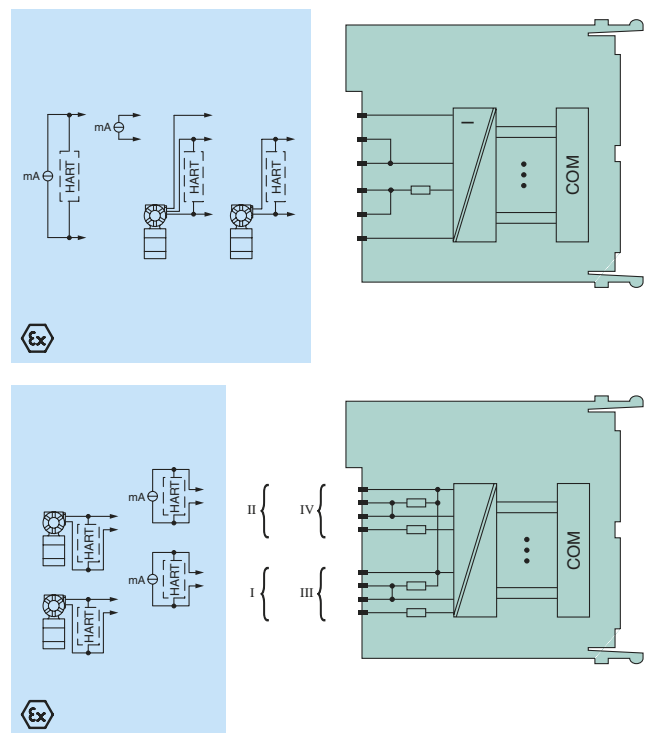

|       | 1 channel      |         | 4 channels  |         |
|-------|----------------|---------|-------------|---------|
|       | Zone 2         | Zone 1  | Zone 2      | Zone 1  |
| Ex ia | LB 3102        | FB 3202 | LB 3105     | FB 3205 |
| Ex ic | LB 3002        |         | LB 3005     |         |
| Ex e  |                | FB 3302 |             | FB 3305 |
| HART  | active/passive |         | active only |         |

Figure 10 Examples analog input

## Analog Output

Analog outputs are used to drive proportional valves, positioners, actuators, local indicators, or I/P (current to pressure) converters. These accurately control pressure or flow in all kinds of process applications.

There are version with short circuit detection for 4 mA ... 20 mA signals. Open circuits cannot be detected because of some field devices featuring non linear impedances.

There are 1-channel analog outputs for high availability or multi-channel devices for high packing density.

Many of the field devices feature HART communications providing additional information vital to the process. In the same way which is employed for transmitters the related digital signal is superimposed on the standard analog output signal.

This not only allows the devices to be configured via the loop but also enables asset management. By way of example a valve can record the number of strokes it has encountered since the last maintenance operation. This information can be accessed via the HART protocol to determine when the next regular service is due. This can save unnecessary down time and reduce maintenance costs.

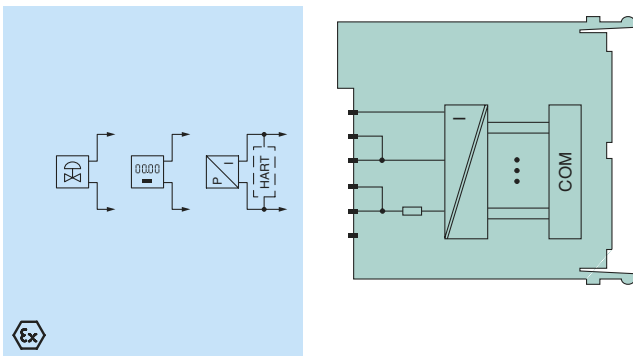

|       | 1 channel |         | 4 channels |         |
|-------|-----------|---------|------------|---------|
|       | Zone 2    | Zone 1  | Zone 2     | Zone 1  |
| Ex ia | LB 4102   | FB 4202 | LB 4105    | FB 4205 |
| Ex ic | LB 4002   |         | LB 4005    |         |
| Ex e  |           | FB 4302 |            | FB 4305 |

Figure 11 Example analog output

## Temperature

One of the most important process variables is temperature. This can be measured by various means. In many cases 2-wire head mounted temperature transmitters are used to be directly connected to transmitter power supplies (see previous chapter). In other cases it may be advantageous to connect the temperature sensors to suitable Remote I/O converters to take the digital signal to the bus.

The following paragraphs explain the features of RTD (Resistance Thermometer Detectors) and thermocouple measurements.

## RTD Temperature Measurements

Resistance thermometer detectors employ the physical effect of a resistor changing its value with a change in temperature of -200 °C to +850 °C. The material used is usually Platinum (Pt100) or Nickel (Ni100). The characteristic is non-linear so the converter not only measures the change in sensor resistance but also linearizes the result.

RTD measurements are based on the principle of a converter sending a small current (< 0.2 mA) to the temperature sensor and measuring the voltage drop which is proportional to the sensor temperature.

RTDs can be connected in 2-wire, 3-wire, or 4-wire configuration.

A 2-wire connection requires a calibration process to compensate for the line resistance. This is either done via an external potentiometer usually to calibrate to a preset value of 20 Ω or as in the case of Remote I/O by measuring the line resistance and entering this parameter in the converter accordingly.

The 2-wire measurement is the most economical method for RTD measurements as regards cabling however it is also the least accurate one. The line resistance of a copper cable also changes with ambient temperature resulting in small changes in the measurement depending on the time of day or season.

3-wire measurement offer the best compromise between cost and accuracy. In this case a third wire is used to allow the converter to eliminate the influence of the cable resistance without a calibration process.

4-wire measurements yield the best accuracy.

Line fault detection (lead breakage/short circuit monitoring) is available.

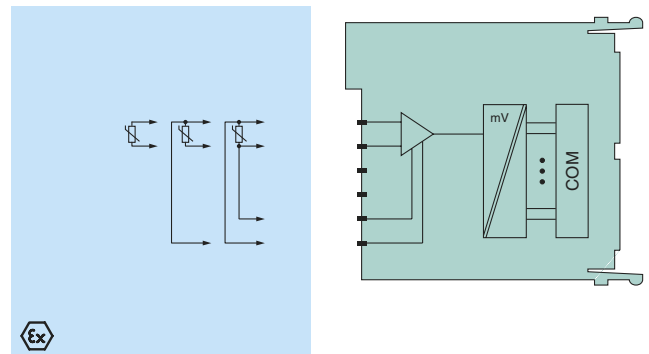

|       | 1 channel |         | 4 channels |         |
|-------|-----------|---------|------------|---------|
|       | Zone 2    | Zone 1  | Zone 2     | Zone 1  |
| RTD   |           |         |            |         |
| Ex ia | LB 5101   | FB 5201 | LB 5104    | FB 5204 |
| Ex ic |           |         | LB 5004    |         |

Figure 12 Example RTD temperature input

### Resistance/Slide Wire Sensors

RTD temperature converters can also be used to measure resistance. In that case the temperature linearization is switched off. The method is used in control applications where a valve position feedback is measured using a potentiometric sensor. Other applications employing changing resistors can equally be accommodated. 2-wire and 3-wire configurations are used to measure full scale values of 500 Ω up to a maximum of 10 kΩ.

### Thermocouple Temperature Measurements

Thermocouple temperature detectors employ the physical effect of a junction of two different types of metal generating a millivolt signal with changing temperatures of -200 °C to +1850 °C.

A variety of materials is used. The characteristic is highly non-linear so the converter not only measures the voltage but also linearizes the result.

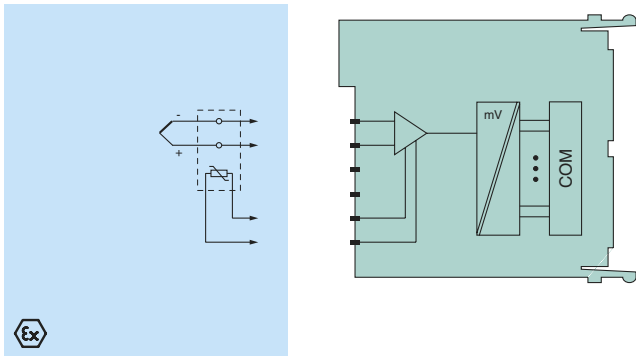

| TC/mV | 1 channel |         | 4 channels |         |
|-------|-----------|---------|------------|---------|
|       | Zone 2    | Zone 1  | Zone 2     | Zone 1  |
| Ex ia | LB 5102   | FB 5202 | LB 5105    | FB 5205 |
| Ex ic |           |         | LB 5005    |         |

Figure 13 Example thermocouple input

### Cold Junction Compensation (CJC)

Thermocouples are formed each time two different types of metal are joined. In order to avoid measurement errors it is therefore necessary to run compensation wires from the sensor to the measuring device or to the cold junction compensation. These wires are matched with the type of thermocouple used.

Without it new thermocouples would be formed at the junction between the compensating cable and the copper wires or indeed the junction terminals. Thus the thermocouple measurement becomes dependent on the ambient temperature at the junction. This temperature dependence can be compensated in various ways.

### Cold Junction Thermostat

The most accurate compensation method and also the most costly is that of a thermostat. This is a temperature controlled junction box which holds the temperature at the junction of the compensating cable and the copper cable at a constant 50 °C. The cold junction temperature is entered as a fixed value parameter for the Remote I/O input device.

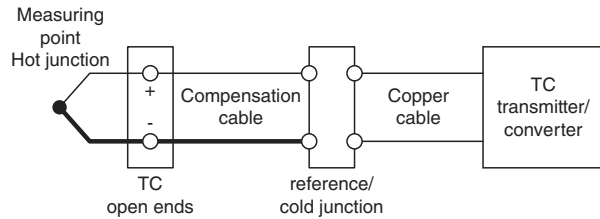

Figure 14 Reference point held at constant temperature

### Cold Junction RTD

As an alternative the cold junction temperature can be measured e. g. using a RTD offering a good compromise between the sophisticated method described above and accuracy.

To achieve the best possible degree of accuracy, the sensor is mounted externally or internally. In both cases the compensating circuit (RTD) must be very close to the incoming compensating wires.

### Galvanic Isolation

Thermocouples are prone to producing ground loops at temperatures beyond 800 °C. Therefore the corresponding converters have been equipped with channel isolation.

### Line Fault Detection (LFD)

A small current is sent to the sensor to allow the converter to detect open circuits. Short circuits cannot be detected since 0 V is also a measured value.

### Millivolt Measurements

A thermocouple transmitter can also be used to measure millivolt signals from other sources. In those cases the linearization and cold junction compensation are turned off.

### Strain Gauge

Strain gauge bridge measurements are used in weighing applications or pressure measurements.

The Remote I/O modules 5\*02 and 4\*01 can be interconnected and used for strain gauge measurements. The output isolator is used to form a constant current, while the measuring input of the thermocouple converter processes the mV signal of the resulting bridge voltage.

The result of the measurement is transmitted to the PLC or DCS via the bus.

A constant current of 20 mA is suitable for the supply of a 350 Ω bridge, whereby the bridge voltage is 7 V. With a sensitivity of the bridge of 2 mV/V, the voltage at full load is 14 mV. Normally there would be a starting and a full scale value.

The principle of a constant current bridge supply eliminates the need for sense wires normally associated with strain gauge bridges employing a constant voltage source. The constant current is unaffected by voltage drops along the cables.

When the two modules are combined, the overall accuracy can be calculated from the mean value of the accuracies of the individual devices.

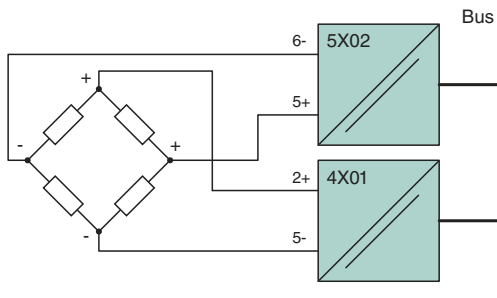

Figure 15 Strain gauge bridge device combination

### Voltage Converter

Sometimes 0 V ... 10 V converters are required e. g. with voltage sources or joystick applications.

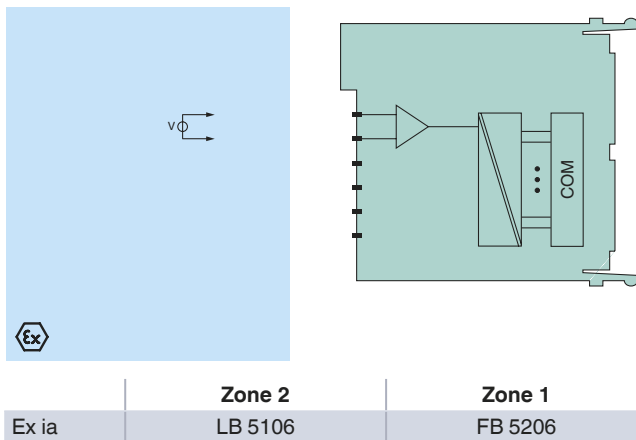

Figure 16 Example voltage input

### Joy Stick Control

The control of cranes and drilling derricks often involves the use of a "joystick". As these instruments are moved in various directions by the operator their movement is reflected in resistor changes. One resistor responds to the forward and reverse movement while the other one changes with the sideways movement. The resistor values vary between zero and approximately 2,700 Ω.

The Pepperl+Fuchs Remote I/O can measure the changing resistors by driving a constant current through the resistor and measuring the voltage drop across the changing resistors. This can be accomplished by using models 4\*01 and 5\*06. The interconnection of these two IS loops can be proven to be safe.

The following block diagram shows how these modules are connected.

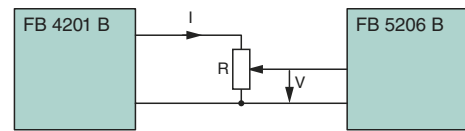

Figure 17 Example Joystick Device Combination for Zone 1

The DCS can be calibrated to the joystick position by driving a current "I" into the resistor "R" when the joystick is moved to its furthest position in one direction. The voltage reading "V" of the 5\*06 device should then show its maximum value. Next the joystick should be moved to the opposite position. The voltage reading should go to zero. In the centre position we shall read about 50 % of the maximum value. The centre position can also be indicated by switch positions on the joystick which can be wired to a digital input module.

As there are two variable resistors per joystick two identical module arrangements are required as explained above.

Edition 912907 (US) / 220718 (EU) 06/2011

### Relay Output

Many of the machine and process automation applications can range from the most basic on/off function to extremely complex sequencing.

Where simple status or alarm indication must be seen or heard, explosion proof strobe lights or rotating lights as well as audible alarms or sounders are employed.

Relay outputs can be used to drive these as well as high power flame proof solenoids, or trip points, or other general purpose switching functions.

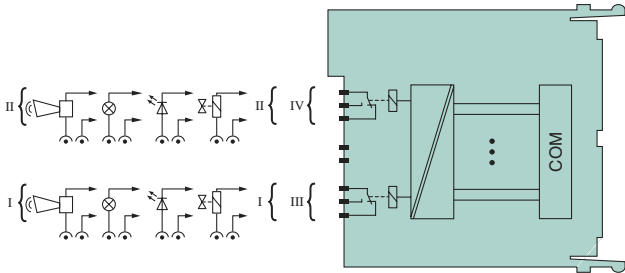

| 24 V/230 V | 2 channels |           | 4 channels |         |
|------------|------------|-----------|------------|---------|
|            | Zone 2     | Zone 1    | Zone 2     | Zone 1  |
| Ex nA      | LB 6101 H  |           | LB 6005    |         |
| Ex e       |            | FB 6301 H |            | FB 6305 |

| 24 V  | 8 channels |         |
|-------|------------|---------|
|       | Zone 2     | Zone 1  |
| Ex nA | LB 6006    |         |
| Ex e  |            | FB 6306 |

Figure 18 Example dual channel relay output

### Digital Output

Similar to relay outputs intrinsically safe digital outputs are used where simple status or alarm indication must be seen or heard, intrinsically safe strobe lights as well as audible alarms or sounders are employed.

Digital outputs also drive IS solenoids, LED clusters, beacons, or fit other general purpose switching functions.

It may be necessary to switch off the line fault detection for LEDs or lights since the device sends out a very small test current to check for open or short circuits. With line fault detection On, LEDs would start to glimmer and sounders might give a murmur.

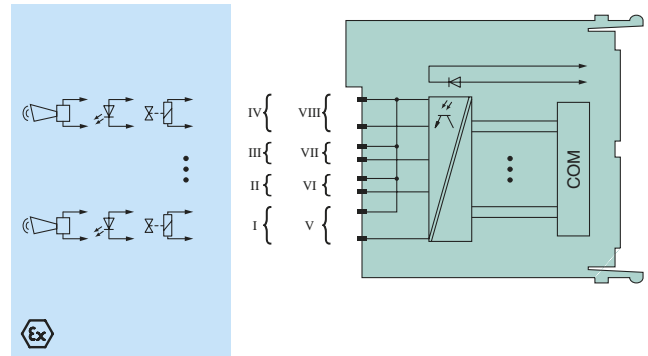

|       | 8 channels |         |
|-------|------------|---------|
|       | Zone 2     | Zone 1  |
| Ex ib | LB 6108    | FB 6208 |
| Ex ic | LB 6008    |         |

Figure 19 Example 8-channel digital input with bus-independent SIL2 shutdown input

Technology

Basic Principles

Applications

Ex Protection  
Intrinsic Safety

Functional  
Safety

## Gateway or Com Unit Selection Guide

The following table is intended to assist you in finding the best gateway or Com Unit for your application.

Gateways LB 8103 or FB 8203 only support single width modules. All other gateways support single channel high integrity modules as well as dual width multi channel modules. LB 8103 or FB 8203 are available mainly as replacements. Gateways LB 8106, FB 8206 are mainly used when the DCS prefers to configure the slaves on the basis of the GSE file only. This is possible with any system which supports PROFIBUS.

PROFIBUS systems which offer more can make use of the superior properties of the UniCOM gateways LB 8109 or FB 8209 (e. g. FDT or Siemens (PDM)). These are compatible with LB 8105 or FB 8205 gateways offering additional CiR functionality independent of the process control system or PLC (online configuration). LB 8105 or FB 8205 are legacy gateways mostly used in connection with ABB systems.

Gateways LB 8107 and FB 8207 are reserved for MODBUS applications.

Gateways LB 8108 are mainly used in connection with non-intrinsically safe applications, where a large number of digital inputs have to be processed.

| Gateway Zone 2, Div. 2                  | LB 8106            | LB 8107    | LB 8109  | LB 8110             | LB 8111    |
|---|--------------------|------------|----------|---------------------|------------|
| Gateway Zone 1                          | FB 8206            | FB 8207    | FB 8209  | FB 8210             | FB 8211    |
| System properties                       | PROFIBUS (GSD, C1) | MODBUS RTU | UniCOM   | FOUNDATION Fieldbus | MODBUS TCP |
| Firmware version                        | 6.*                | 7.*        | 9.*      | 1.*                 | ≥ 7.53     |
| Operating interface or DTM for FDT 0.98 |                    | 6          |          |                     | ≥ 7.5      |
| Operating interface or DTM for FDT 1.2  | ≥ 7.5              | ≥ 7.5      | 7        | 7                   | ≥ 7.5      |
| Service bus required                    |                    | ■          |          |                     |            |
| Service bus useable                     | ■                  | ■          | ■        | ■                   | ■          |
| HART via Service bus                    | ■                  | ■          | ■        | ■                   | ■          |
| HART via PROFIBUS                       | ■                  | ■          | ■        |                     | ■          |
| HART secondary, cyclic                  | ■                  | ■          | ■        |                     | ■          |
| GSD/GSE file                            | CGV61711           |            | CGV61710 |                     |            |
| PROFIBUS DP                             | ■                  |            | ■        |                     |            |
| PROFIBUS DPV1                           | ■                  |            | ■        |                     |            |
| FOUNDATION Fieldbus                     |                    |            |          | ■                   |            |
| MODBUS                                  |                    | ■          |          |                     | ■          |
| Redundancy                              | ■                  | ■          | ■        |                     | ■          |
| HCiR                                    | ■                  |            | ■        |                     |            |
| CiR                                     |                    |            | ■        |                     |            |
| System independent, online configurable |                    | ■          | ■        | ■                   | ■          |

Gateways listed here support all of the modules as per the following data sheets

Restriction: Gateways LB 8110 and FB 8210 only support dual width modules. See the corresponding data sheets for details.

Table 1 Selection table



Technology

Basic Principles

Applications

Ex Protection  
Intrinsic Safety

Functional  
Safety

Edition 912907 (US) / 220718 (EU) 06/2011

# Overview of Explosion Protection and Intrinsic Safety

## Hazardous Locations and Protection Methods

### Introduction

This document deals with the physical principles and fundamentals of explosion protection and with the legal situation of the two division model (North America) and the three zone model (Europe and IEC countries) of hazardous (classified) locations. Regardless of geographic location, the physical principles of explosion protection are identical. What differentiates one country from another are national deviations and varying requirements associated with the explosion protection methods. In very general terms, we can differentiate between the IEC and North American concepts.

After World War II, the increased use of oil and its derivatives brought the construction of a great number of plants for extraction, refining, and transformation of the chemical substances needed for technological and industrial development.

The treatment of dangerous substances, where there exists the risk of explosion or fire that can be caused by an electrical spark or hot surface, requires specifically defined instrumentation, located in a hazardous location. It also requires interfacing signals coming from a hazardous location to be unable to create the necessary conditions to ignite and propagate an explosion.

This risk of explosion or fire has been the limiting factor when using electrical instrumentation because energy levels were such that the energy limitation to the hazardous location was difficult, if not impossible, to obtain. For this reason, those parts of the process that were considered risky were controlled with pneumatic instrumentation.

The introduction of semiconductor devices (transistors first and, subsequently, integrated circuits), along with the capability to reduce the working voltages and energy levels, made the energy-limitation protection technique, called intrinsic safety, easier to apply when using electronic instrumentation in hazardous locations. Thus, a more economical and more efficient solution to the problem was created.

The purpose of this publication is to:

- explain the principles on which the protection techniques against the danger of explosion are based
- present intrinsic safety and its application to anyone who faces the problems relative to design, installation, and maintenance

### Introduction to Intrinsic Safety

In England, the 1913 methane gas explosion in a coal mine caused the loss of many lives. The inquiring commission in charge of the investigation debated at length whether or not the explosion was caused by the low-voltage signaling system that was used to advise the surface crew that coal cars were ready to be brought to the surface.

The signaling system, composed of a set of batteries and a bell, was activated by shorting, with a metallic tool or by hand, two bare conductors routed along the mine's galleries (refer to Figure 1). The system was considered safe because the low voltage and current level in the circuit were within recognized safety parameters.

The research that followed revealed that the most important factor in determining the safety of an electrical circuit is the energy stored in the circuit. Without the use of proper limitation methods, the inductive energy stored in the bell and wiring produced energy levels sufficient enough to generate an electric arc that was able to ignite the dangerous air/gas mixture – causing the fatal explosion.

The concept of intrinsic safety was born.

The electrical apparatus and its associated circuits had to be designed in a manner that would prevent the generation of arcs, sparks, or thermal effects that could ignite a potentially dangerous substance, during both normal and fault conditions of the circuit.

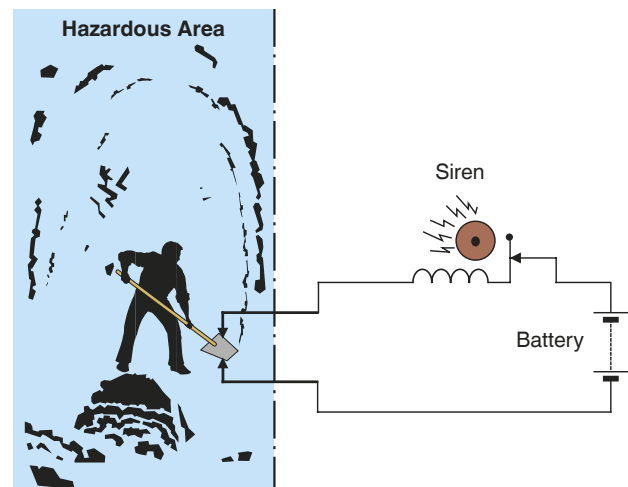

Figure 1 Mine signaling system erroneously considered safe causes an explosion

The first regulation for testing and certification of signaling systems for mines was issued. Subsequently, the study of the lighting mechanism was expanded to include alternative current (AC) circuits and other dangerous gas mixtures.

The intrinsic safety concept was then applied to the surface industries where explosive atmospheres, i. e., containing hydrogen or acetylene, are easier to ignite than the methane present in coal mines.

## Physical Fundamentals of Explosion Protection

### Ignition Triangle

From a chemical point of view, oxidation, combustion, and explosion are all exothermic reactions with different reaction speeds. For such reactions to take place, it is essential that the following three components be present simultaneously in suitable proportions:

- Fuel: flammable vapors, liquids or gases, or combustible dusts or fibers,
- Oxidizer: generally air or oxygen,
- Ignition energy: electrical or thermal.
- These three components are identified in the ignition triangle displayed in Figure 2.

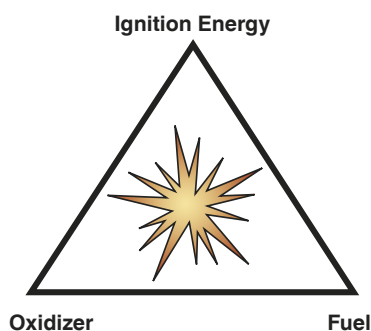

Figure 2 Ignition triangle

Once the reaction is ignited, depending on how the exothermic energy is released, the results can be a controlled combustion, flame wave, or explosion.

All protection methods used today are based on eliminating one or more of the triangle components in order to reduce the risk of explosion to an acceptable level. In a properly designed safety system, it is generally acceptable that two or more independent faults must occur, each one of low probability, before a potential explosion can occur.

There are also materials that can explode spontaneously without supplied energy; however, this subject will not be addressed here. This publication deals with the prevention of explosions that can be ignited.

### Explosive Mixture Characteristics

The risk of an ignition of an air/gas mixture depends on the probability of the simultaneous presence of the following two conditions:

- Formation of flammable or explosive vapors, liquids or gases, or combustible dusts or fibers with atmosphere or accumulation of explosive or flammable material;
- Presence of an energy source – electrical spark, arc, or surface temperature – that is capable of igniting the explosive atmosphere present.

It is possible to draw an ignition characteristic for each type of fuel. The characteristic curves of hydrogen and propane are illustrated in Figure 3. A **Minimum Ignition Energy (MIE)** exists for every fuel and represents the ideal ratio of fuel to air. At this ratio, the mixture is most easily ignited. Below the MIE, ignition is impossible for any concentration.

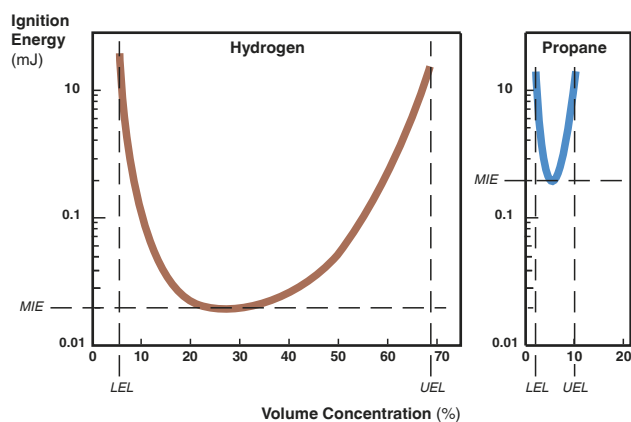

Figure 3 Ignition energy in relation to hydrogen and propane air/gas concentration

For a concentration lower than the one corresponding to the MIE, the quantity of energy required to ignite the mixture increases until a concentration value is reached below which the mixture cannot be ignited due to the low quantity of fuel. This value is called the **Lower Explosive Limit (LEL)**. In the same way, when increasing the concentration the energy requirement increases, and a concentration value is identified above which ignition cannot occur due to the low quantity of an oxidizer. This value is called the **Upper Explosive Limit (UEL)**.

For example, the following table lists the explosive characteristics of hydrogen and propane.

|          | MIE    | LEL | UEL   |
|----------|--------|-----|-------|
| Hydrogen | 20 μJ  | 4 % | 75 %  |
| Propane  | 180 μJ | 2 % | 9.5 % |

Table 1 Explosive characteristics of hydrogen and propane

From a practical point of view, LEL is more important and significant than UEL because it establishes, percentage-wise, the minimum quantity of gas needed to create an explosive mixture. This data is important when classifying hazardous locations.

The MIE (minimum energy required to ignite an air/gas mixture in the most favorable concentration) is the factor upon which the intrinsic safety technique is based. With this technique, the energy released by an electrical circuit, even under fault conditions, is limited to a value lower than the MIE.

## Ignition Temperature

The minimum ignition temperature of an air/gas mixture is the temperature at which the explosive atmosphere ignites without electrical energy being supplied.

This parameter is important because it establishes the maximum surface temperature allowed for devices located in a hazardous location, under both normal and fault conditions. This must always be lower than the ignition temperature of the gas present.

## Flash Point Temperature

The flash point temperature is a characteristic of a volatile liquid, and it is defined as the lowest temperature at which the liquid releases sufficient vapors that can be ignited by an energy source.

Since a liquid above its flash point constitutes a source of danger, this parameter must be considered when classifying locations.

## Evaluation of Explosion Risk

In any situation involving an explosive material, the risk of ignition must be taken into account. Generally, this evaluation will involve industry specialists, safety and mechanical engineers as well as chemists and other critical facility personnel.

In addition to the nominal rating of materials under consideration, parameters related to the process involved are especially important in the evaluation. As an example, the risk of explosion may be caused by the evaporation of a liquid or by the presence of liquid sprayed under high pressure.

It is also important to know what atmospheric conditions are present normally and abnormally. The range of concentration between the explosion limits generally increases as the pressure and temperature of the mixture increases. The relationship between explosion limits and flash point for ethyl alcohol is illustrated in Figure 4.

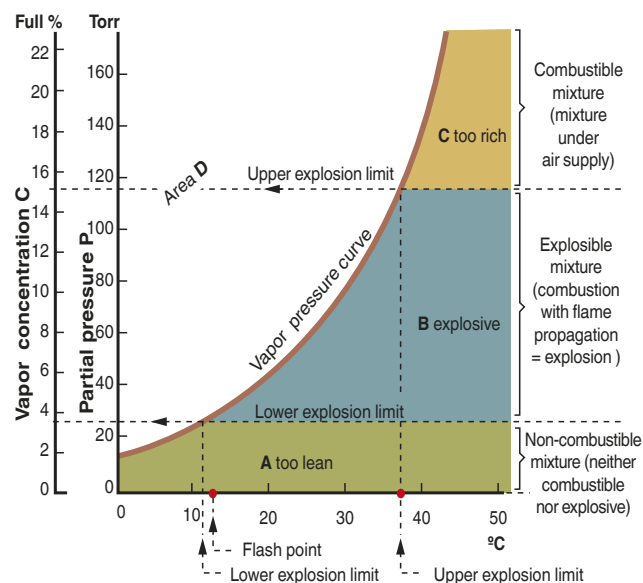

Figure 4 Graph representing the vapor pressure of ethyl alcohol

The atmosphere is capable of exploding within the explosion limits and is shown as area B of the image. Area A is below the LEL; therefore, the mixture is no longer capable of ignition since it is too "lean". The mixture is also not capable of ignition in area C since it is too "rich" (i. e. the oxygen content is too low for an explosion). If air is introduced, the mixture will again become flammable.

In the area surrounding the vapor pressure curve (area D), mixtures are in equilibrium; therefore, a gas that is handled or stored within the critical temperature range of area B is explosive.

The flash point is generally a few degrees above the lower explosive limit. A liquid is considered flammable if its flash point is below 38 °C (100.4 °F) while it is considered combustible if its flash point is above 38 °C (100.4 °F).

## Classification of Hazardous Areas

Although the physical principles of explosion protection are the same worldwide and are not differentiated, the procedures determined by national legislation in the approximately 100-year history of explosion protection have resulted in various solutions.

### Hazardous Areas and Apparatus

Determining hazardous areas in a plant is normally performed by experts of various disciplines. It may be necessary for chemists, process technologists, and mechanical engineers to cooperate with an explosion protection expert in order to evaluate all hazards. The possible presence of a potentially explosive atmosphere as well as its properties and the duration of its occurrence must be established.

Hazardous areas are most frequently found in places where there is a possibility of an emission of flammable gas or dust. The hazardous area can occur in normal operation, in the event of a fault, or due to wear and tear of seals or other components.

A hazardous area ranges from the area of release to areas in which the affected substance is so diluted with air that ignition is no longer possible (LEL). The extent of the area is dependent on the type and quantity of released gases, degree of ventilation, or other similar conditions.

Many areas are designated as hazardous due to the presence of flammable gas. However the hazard associated with flammable dust is equally significant, since dispersed dust can also lead to explosions. An explosion hazard due to flammable dust can occur in various sectors of industry, for example, food products (e. g. confectionery, starch, flour, feed yeast), plastics, timber, rubber, furniture, textiles, pesticides, medicines, dyes, coal, metals (e. g. aluminum, chrome, iron, magnesium and zinc) as well as in electricity generation from fossil fuels.

Today, expressed in rather simple terms, we can differentiate between the IEC and the North American procedure. The differences lie in the categorization of hazardous areas, the design of apparatus, and the installation technology of electrical systems. The categorization of these areas is carried out in North America in accordance with the National Electrical Code NFPA 70, article 500 according to material groups (Class I: gases, vapors, and mist; Class II: dust; Class III: fibers and suspended particles) and a further categorization according to the probability of occurrence of these materials being present in a potentially hazardous quantity (Division 1 and Division 2).

## Two Division Model

Hazardous areas are dependent on the type of flammable materials present and are divided into the following three categories:

|                  |   |
|------------------|---|
| <b>Class I</b>   | Locations containing flammable gases, flammable liquid-produced vapors, or combustible liquid-produced vapors |
| <b>Class II</b>  | Locations containing combustible dusts  |
| <b>Class III</b> | Locations containing fibers and flyings   |

Table 2

The probability of occurrence of these materials is taken into consideration through the classification into divisions:

|                   | <b>Class I (Gases and Vapors)</b>  | <b>Class II (flammable Dust or Powder)</b>  | <b>Class III (flammable Fibers or suspended Particles)</b>  |
|-------------------|--|---|---|
| <b>Division 1</b> | In accordance with NEC 500.5 and CEC J18-004<br><br>Areas containing dangerous concentrations of flammable gases, vapors or mist continuously or occasionally under normal operating conditions. | In accordance with NEC 500.6 and CEC 18-008<br><br>Areas containing dangerous concentrations of flammable dusts continuously or occasionally under normal operating conditions. | Divisions in accordance with NEC 500.7 and CEC 18-010<br><br>Areas containing dangerous concentrations of flammable fibers or suspended particles continuously or occasionally under normal operating conditions. |
| <b>Division 2</b> | Areas probably not containing dangerous concentrations of flammable gases, vapors or mist under normal operating conditions.   | Areas probably not containing dangerous concentrations of flammable dusts under normal operating conditions.  | Areas probably not containing dangerous concentrations of flammable fibers or suspended particles under normal operating conditions.  |

Table 3

Classes of hazardous areas are divided into sub-groups dependent on the type of flammable gas or vapor present:

| <b>Class I</b>  | <b>Group A</b> | Atmospheres containing acetylene  |
|-----------------|----------------|---|
|                 | <b>Group B</b> | Atmospheres containing hydrogen and flammable process gasses with more than 30 % hydrogen by volume, or gases or vapors posing a similar risk level such as butadiene and ethylene oxide  |
|                 | <b>Group C</b> | Atmospheres such as ether, ethylene or gases or vapors posing a similar risk level  |
|                 | <b>Group D</b> | Atmospheres such as acetone, ammonia, benzene, butane, cyclopropane, ethanol, gasoline, hexane, methanol, methane, natural gas, naphtha, propane or gases or vapors posing a similar risk level   |
| <b>Class II</b> | <b>Group E</b> | Atmosphere containing combustible metal dusts, including aluminum, magnesium and their commercial alloys, or other combustible dusts whose particle size, abrasiveness and conductivity present similar hazards in the use of electrical equipment                  |
|                 | <b>Group F</b> | Atmospheres containing combustible carbonaceous dusts including carbon black, charcoal, coal, or coke dusts that have more than 8 percent total entrapped volatiles, or dusts that have been sensitized by other materials so that they present an explosion hazard |
|                 | <b>Group G</b> | Atmospheres containing combustible dusts not included in Group E or Group F, including flour, grain, wood, plastic, and chemicals   |

Table 4

The sub-groups and the gases contained within each sub-group are based on the **Maximum Experimental Safe Gap (MESG)** or the **Minimum Ignition Current (MIC)**.

**Class III**

- Class III hazardous locations are those that are hazardous because of the presence of easily ignitable fibers or flyings, but in which such fibers or flyings are not likely to be in suspension in the air in quantities sufficient to produce ignitable mixtures.
- Class III, Division 1 locations are those in which easily ignitable fibers or flyings are handled, manufactured or used.
- Class III, Division 2 locations are those in which easily ignitable fibers or flyings are stored or handled.
- Locations belonging in this class usually include parts of textile mills, cotton gins, flax-processing plants, clothing manufacturing plants, woodworking plants, etc.
- Easily ignitable fibers and flyings include rayon, cotton, sisal, hemp, cocoa fiber, kapok, Spanish moss, excelsior, etc.
- Class III locations are not further subdivided.

Figure 5 shows a gas tank with a fixed roof and vent as a typical example of a Class I hazardous area applicable in North America with categorization into Divisions 1 and 2.

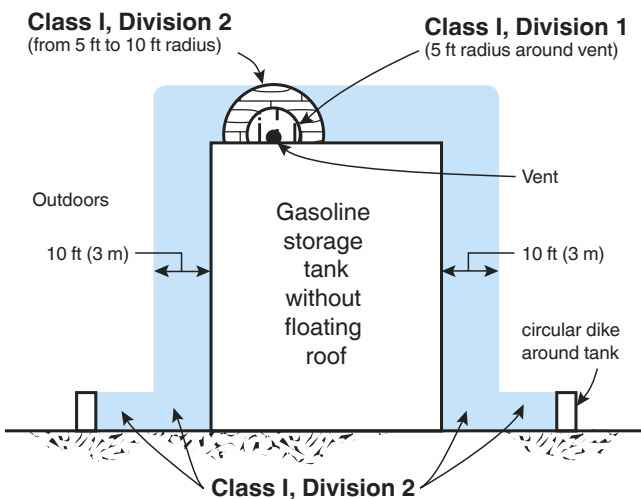

Figure 5 Schematic of a division-based area classification of a fuel tank with fixed lid and breather

**Zone Model in North America and Canada**

In 1988 in Canada, plants for Class I applications were transferred to the 3-zone concept of the IEC. For plants built after 1988, the 3-zone concept is mandatory (CEC, 1988 edition). In 1996 in North America, the NEC 505 section was introduced for Class I applications. Since the time of this addition to the NEC, area classification according to the IEC zones has been an option for companies.

**Class I (Gases and Vapors)**

Zones in accordance with NEC 505.5 and CEC 18-006:

|               |   |
|---------------|---|
| <b>Zone 0</b> | Areas containing dangerous concentrations of flammable gases, vapors, or mist continuously or for long periods under normal operating conditions.                                 |
| <b>Zone 1</b> | Areas containing dangerous concentrations of flammable gases, vapors, or mist during normal operating conditions, during repair or maintenance operations, or because of leakage. |
| <b>Zone 2</b> | Areas likely to contain not containing dangerous concentrations of flammable gases, vapors, or mist under normal operating conditions.  |

Table 5

However, in North America the traditional division practice dominates and the opportunity for zone classification is seen as secondary. As a comparison, the division practice in North America is compared to the zone practice in Europe in the following section.

**Three Zones Model**

The European zone practice is described in IEC/EN 60079-10. In accordance with this standard, any area in which there is a probability of a flammable gas or dispersed dust to exist must be classified into one of the following areas.

|                |  |
|----------------|--|
| <b>Zone 0</b>  | An area in which an explosive air/gas mixture is continuously present or present for long periods.                   |
| <b>Zone 1</b>  | An area in which an explosive air/gas mixture is likely to occur in normal operation.                                |
| <b>Zone 2</b>  | An area in which an explosive air/gas mixture is unlikely to occur; but, if it does, only for short periods of time. |
| <b>Zone 20</b> | An area in which a combustible dust cloud is part of the air permanently, over long periods of time or frequently.   |
| <b>Zone 21</b> | An area in which a combustible dust cloud in air is likely to occur in normal operation.                             |
| <b>Zone 22</b> | An area in which a combustible dust cloud in air may occur briefly or during abnormal operation.                     |

Table 6

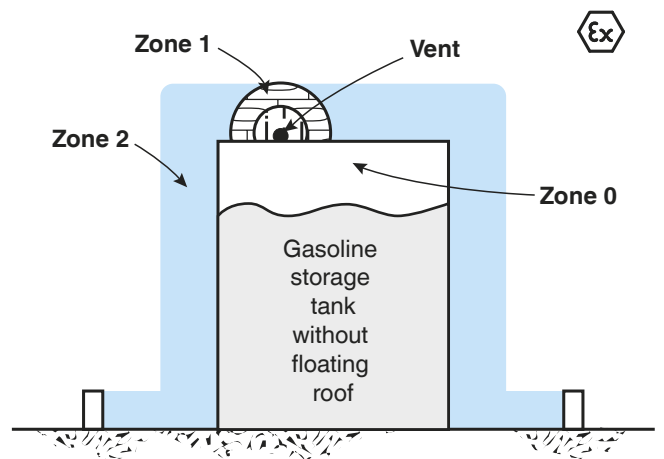

Figure 6 Schematic of a zone-based area classification of a fuel tank with fixed lid and breather

In practical implementation, relevant national regulations for zone classification, installation, and operation of a plant are to be observed. These national regulations may differ or support IEC regulations.

## Classification of Apparatus for Zones

European standard EN 60079-0 requires apparatus to be subdivided into two groups:

|                 |  |
|-----------------|--|
| <b>Group I</b>  | Apparatus to be used in mines where the danger is represented by methane gas and coal dust.  |
| <b>Group II</b> | Apparatus to be used in surface industries where the danger is represented by gas and vapor that has been subdivided into three groups: A, B and C. These subdivisions are based on the <b>Maximum Experimental Safe Gap (MESG)</b> for an explosion-proof enclosure or the <b>Minimum Ignition Current (MIC)</b> for intrinsically safe electrical apparatus. |

Table 7

The groups indicate the types of danger for which the apparatus has been designed. Since Group I is intended for mines, this subject will not be addressed in this publication.

Group II concerns above-ground industries (electrical apparatus for hazardous areas with potentially explosive gas (dust) atmosphere except firedamp hazardous mining areas) and is subdivided into II G (gases) and II D (dusts).

### Differences between Division and Zone Practices

The following table shows the differences between the North American and European practices, regarding the classification of hazardous locations.

| Method          | Constant risk | Occasional risk | Risk only in the case of a fault |
|-----------------|---------------|-----------------|----------------------------------|
| <b>Division</b> | Division 1    |                 | Division 2                       |
| <b>Zone</b>     | Zone 0/20     | Zone 1/21       | Zone 2/22                        |

Table 8 Classification of hazardous areas

It is evident from the above table that Zone 2/22 (IEC/Europe) and Division 2 (North America) are almost equivalent, while Division 1 includes the corresponding Zones 0/20 and 1/21. An instrument designed for Zone 1/21 cannot necessarily be directly used in Division 1. In the stated definition from the cited standard, no quantification of the expressions "long period of time" for Zone 0/20, "can be present" for Zone 1/21 and Division 1, and "not normally present" for Zone 2/22, is given.

The main difference between the North American and the European classification of hazardous locations is that there is currently no direct equivalent to the European Zone 0 in the North American system. Zone 0 is therefore the most dangerous. An instrument designed for Zone 0 must be incapable of generating or accumulating sufficient energy to ignite the fuel mixture.

In Europe, the apparatus are certified on the basis of design and construction characteristics. From a practical point of view, the two systems are equivalent even if there are minor differences, as shown in the following table.

| Materials                    | Apparatus classification |                   | Ignition energy |
|------------------------------|--------------------------|-------------------|-----------------|
|                              | Europe (* IEC)           | North America     |                 |
| Methane                      | Group I (mining)         | Class I, Group D  |                 |
| Acetylene                    | Group IIC                | Class I, Group A  | > 20 μJ         |
| Hydrogen                     | Group IIC                | Class I, Group B  | > 20 μJ         |
| Ethylene                     | Group IIB                | Class I, Group C  | > 60 μJ         |
| Propane                      | Group IIA                | Class I, Group D  | > 180 μJ        |
| Conductive dust (metal)      | Group IIIC*              | Class II, Group E |                 |
| Non-conductive dust (carbon) | Group IIIB*              | Class II, Group F |                 |
| Cereal/flour                 | Group IIIB*              | Class II, Group G |                 |
| Fibers/suspended particles   | Group IIIA*              | Class III         |                 |

Table 9 Classification of apparatus in North America, IEC and Europe

\* The current IEC 60079-0 standard now contains dust protection requirements and defines dust atmospheres as Groups IIIC, IIIB and IIIA. Caution: according to directive 94/9/EC, explosion protection for dust atmospheres is still listed as Group II D in Europe.

Each subgroup of Group II and of Class I is associated with a certain number of gases having an ignition energy included in the value reported and is represented by the gas referenced in the above table that is used in certification tests.

Group IIC and Class I, Groups A and B are the most dangerous because they require the lowest level of ignition energy. An apparatus designed for these groups must be incapable of igniting, by electrical means, any potentially explosive air/gas mixture.

### Classification of Surface Temperature for Divisions and Zones

Apparatus installed directly in a hazardous area must be classified for the maximum surface temperature that the device will produce under normal operation or in the event of a fault. The maximum surface temperature must be below the minimum ignition temperature of the gas present.

In the USA and Canada (as in Europe), six temperature classes are differentiated, T1 to T6. The classes T2, T3, and T4 are however divided into further subclasses, as indicated in the following table.

| Maximum temperature |     | Temperature class in North America |
|---------------------|-----|------------------------------------|
| °C                  | °F  |                                    |
| 450                 | 842 | T1                                 |
| 300                 | 572 | T2                                 |
| 280                 | 536 | T2A                                |
| 260                 | 500 | T2B                                |
| 230                 | 446 | T2C                                |
| 215                 | 419 | T2D                                |
| 200                 | 392 | T3                                 |
| 180                 | 356 | T3A                                |
| 165                 | 329 | T3B                                |
| 160                 | 320 | T3C                                |
| 135                 | 275 | T4                                 |
| 120                 | 248 | T4A                                |
| 100                 | 212 | T5                                 |
| 85                  | 185 | T6                                 |

Table 10 Classification of surface temperature

Each gas is allocated to a temperature class according to its ignition temperature. Please note that for all specific mixtures, there is no connection between ignition energy and ignition temperature.

Hydrogen for example has a minimum ignition energy of 20  $\mu\text{J}$  and an ignition temperature of 560 °C (1040 °F), whereas acetaldehyde has an ignition energy of over 180  $\mu\text{J}$  and an ignition temperature of 140 °C (284 °F).

An apparatus classified for a particular temperature class can be used in the presence of all gases, provided that its ignition temperature is above the temperature class rating of the particular device. For example, a T5 classified apparatus can be used with all gases, the ignition temperature of which is above 100 °C (212 °F).

**Important: For all explosion protection methods, a temperature classification is required with regard to all surfaces that could come into contact with a potentially explosive atmosphere.**

## Ignition Protection Methods

In order to reduce the risk of explosion, elimination of one or more of the components of the ignition triangle is necessary (refer to "Ignition Triangle" section for a discussion). There are three basic methods of protection – explosion containment, segregation, and prevention.

- **Explosion containment:** The only method that allows the explosion to occur but confines it to a well-defined area, thus avoiding the propagation to the surrounding atmosphere. Flame-proof and explosion-proof enclosures are based on this method.
- **Segregation:** A method that attempts to physically separate or isolate the electrical parts or hot surfaces from the explosive mixture. This method includes various techniques, such as pressurization, encapsulation, etc.
- **Prevention:** A method that limits the energy, both electrical and thermal, to safe levels under both normal operation and fault conditions. Intrinsic safety is the most representative technique of this method.

## Selecting a Protection Method

First of all, the normal functioning of the apparatus must be considered. Secondly, eventual malfunctioning of the apparatus due to faulty components must be a consideration. Lastly, all those conditions that can accidentally occur, such as a short circuit, open circuit, grounding, and erroneous wiring of the connecting cables, must be evaluated.

The choice of a specific protection method depends on the degree of safety needed for the type of hazardous location considered in such a way as to have the lowest probable degree of an eventual simultaneous presence of an adequate energy source and a dangerous concentration level of an air/gas mixture.

None of the protection methods can provide absolute certainty of preventing an explosion. Statistically, the probabilities are so low that not even one incident of an explosion has been verified when a standardized protection method has been properly installed and maintained.

The first precaution to be used is to avoid placing electrical apparatus in hazardous locations. When designing a plant or factory, this factor needs to be considered. Only when there is no alternative should this application be allowed.

Other secondary, but important, factors for consideration are the size of the apparatus to be protected, the flexibility of the system, the possibility of performing maintenance, the installation cost, etc. Respective of these factors, intrinsic safety has many advantages; however, to better understand these advantages, it is necessary to know and understand the limitations of the other protection methods.



The purpose of this section is to briefly present the different methods of protection. In Europe, CENELEC and IEC standards refer to protection methods with symbols, such as Ex d for the flame-proof method. These symbols are not used by the United States and Canada for Division rated products.

Using the symbol and labeling of the relevant apparatus, the protection method in use can be easily identified. The same applies to North America and Canada when the CEC zone method or NEC 505 (American conversion of the IEC recommendations for gases and vapors) are used.

|                                  |      |
|----------------------------------|------|
| Oil immersion                    | Ex o |
| Powder filling                   | Ex q |
| Encapsulation                    | Ex m |
| Pressurization                   | Ex p |
| Increased safety                 | Ex e |
| Flame-proof                      | Ex d |
| Intrinsic safety                 | Ex i |
| Ignition protection n            | Ex n |
| Intrinsically safe systems       | Ex i |
| Apparatus with optical radiation | op   |

Table 11 Code designation of protection methods for hazardous gas areas according to IEC 60079-X and NEC 505

The same ignition protection classes exist in the North American zone methods as identified in the appropriate IEC 60079-X series standards.

### Flame-proof and Explosion-proof Enclosure

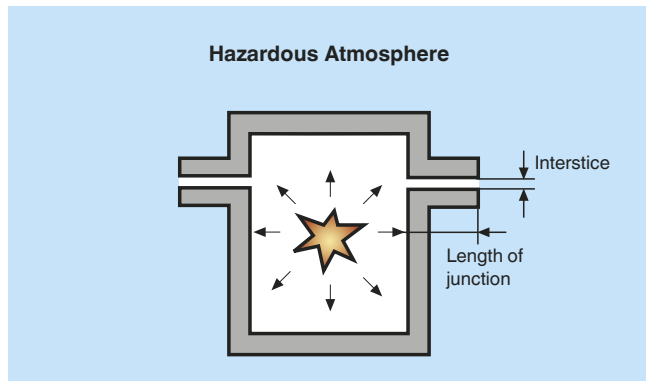

Figure 7 Schematic diagram of a flame-proof enclosure (IEC 60079-1, EN 60079-1, FM 3615, UL 2279.P1)

This protection method is the only one based on the explosion-containment concept. In this case, the energy source is permitted to come in contact with the dangerous air/gas mixture. Consequently, the explosion is allowed to take place, but it must remain confined in an enclosure built to resist the excess pressure created by an internal explosion, thus impeding the propagation to the surrounding atmosphere.

The theory supporting this method is that the resultant gas jet coming from the enclosure is cooled rapidly through the enclosure's heat conduction and the expansion and dilution of the hot gas in the colder external atmosphere. This is only possible if the enclosure openings or interstices have sufficiently small dimensions.

### Distinctions for Two Division Model

In North America, a flame-proof enclosure (in accordance with IEC) is as a rule equated with the "flame-proof" designation. In both considerations, the housing must be designed for a x1.5 explosion overpressure. The North American version "Explosion-proof" (XP) must withstand a maximum explosion overpressure of x4.

Furthermore, in North America the installation regulations (NEC 500) specify metal conduit to be used for the field wiring installation. It is also assumed here that the air-gas mixture can also be present within the conduit system. Therefore, the resulting explosion pressures must be taken into consideration. The conduit connections must be constructed according to specification and sealed (i. e. lead seals) with appropriate casting compound.

The housing is not constructed gas-tight. Of course, large openings are not permitted on the enclosure, but small ones are inevitable at any junction point. Some of these gaps may serve as pressure relief points. Escaping hot gases are cooled to the extent that they cannot ignite the potentially explosive atmosphere outside the housing. Ignition is prevented if the minimum temperature and minimum ignition energy of the surrounding potentially explosive atmosphere is not reached. For this reason, the maximum opening allowed for a particular type of joint depends on the nature of the explosive mixture and width of the adjoining surfaces (joint length).

The classification of a flame-proof enclosure is based on the gas group and the maximum surface temperature which must be lower than the ignition temperature of the gas present.

## Installation and Maintenance Problems of Explosion-Proof Enclosures

Often, explosion-proof enclosures have installation and maintenance problems that can be summarized as follows:

- A medium-weight enclosure is very heavy, and its installation creates mechanical and structural complications.
- Particularly corrosive atmospheric conditions (characteristic of chemical or petrochemical plants, or oil platforms), require the use of material such as stainless steel or bronze, resulting in dramatically higher costs.
- Cable entries require a particular arrangement (reductions, cable clamps, conduits, metal-clad cable, sealing) and, in some cases, such items may represent a cost higher than the enclosures themselves.
- In a particularly humid atmosphere, condensation may cause problems inside the enclosure or conduit pipe.
- The safety of an explosion-proof enclosure is based entirely on its mechanical integrity; therefore, periodic inspections are needed.
- Opening of the enclosure is not permitted while the apparatus is functioning; this may complicate maintenance and inspection operations. Usually, the process must shutdown and the area inspected in order to perform routine maintenance.
- It is difficult to remove the lid (a special tool is needed or sometimes 30 to 40 bolts must be unscrewed). After removing the lid, it is important to ensure the integrity of the joint before restarting the system.
- Changes to the system are difficult to implement.

The degree of safety of an explosion-proof enclosure, over time, depends on the correct use and maintenance by the plant personnel. Because of this vulnerability, the flame-proof method is not always allowed, such as in the European Zone 0.

In the United States, not having a direct equivalent to Zone 0, there are particular restrictions in using explosion-proof enclosures in Division 1. Practically speaking, it is not allowed in any location that would be classified as Zone 0.

This protection method is one of the most widely used and is suitable for electrical apparatus located in hazardous locations where high levels of power are required, such as for motors, transformers, lamps, switches, solenoid valves, actuators, and for all parts that generate sparks. On the other hand, practical matters such as high maintenance and calibration costs make the use of this method less cost effective than that of intrinsic safety.

## Purging or Pressurization Method

Purging or pressurization is a protection method based on the segregation concept. This method does not allow the dangerous air/gas mixture to penetrate the enclosure containing electrical parts that can generate sparks or dangerous temperatures. A protective gas – air or inert gas – is contained inside the enclosure with a pressure slightly greater than the one of the external atmosphere (refer to Figure 8).

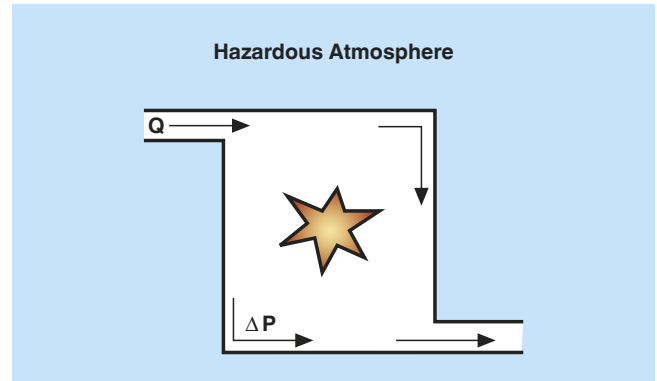

Figure 8 Schematic diagram of a pressurizing system (IEC 60079-2, EN 60079-2, FM 3620 and NFPA 496)

The internal overpressure remains constant with or without a continuous flow of the protective gas. The enclosure must have a certain degree of tightness; however, there are no particular mechanical requirements because the pressure supported is not very high.

To avoid pressure loss, the protective gas supply must be able to compensate, during operation, for enclosure leakage and access by personnel where allowed (the use of two interlocked doors is the classical solution).

Because it is possible for the explosive atmosphere to remain inside the enclosure after the pressurization system has been turned off, it is necessary to expel the remaining gas by circulating a certain quantity of protective gas before restarting the electrical equipment.

The classification of the electrical apparatus must be based on the maximum external surface temperature of the enclosure, or the maximum surface temperature of the internal circuits that are protected with another protection method and that remain powered even when the protective gas supply is interrupted.

The purging or pressurization technique is not dependent upon the classification of the gas. Rather, the enclosure is maintained at a pressure higher than the dangerous external atmosphere, preventing the flammable mixture from coming in contact with the electrical components and hot surfaces inside.

## Two Division Model

In the United States, the term "pressurization" is limited to Class II applications. This is the technique of supplying an enclosure with clean air or an inert gas, with or without continuous flow, at sufficient pressure to prevent the entrance of combustible dusts. Internationally, the term "pressurization" refers to a purging technique for Zones 1 and 2.

The two division model of the purging protection method is based on the reduction of the classification inside the enclosure to a lower level. The following three types of protection (X, Y, and Z) are identified in relation to the hazardous-location classification and the nature of the apparatus.

### Types of protection in relation to classification and nature of apparatus

- Type X: reduces the inside of the enclosure from Division 1 to a non-hazardous state that requires an automatic shutdown of the system in case of pressure loss.
- Type Y: reduces the inside of the enclosure from Division 1 to Division 2.
- Type Z: reduces the inside of the enclosure from Division 1 to a non-hazardous state, requiring alarm signals only.

## Three Zones Model

The European standard regarding this protection method, EN 60079-2, requires that particular safety systems function regardless of internal protective gas loss due to leakages, shutdowns, compressor breakdowns or operator errors.

Pressurization is allowed as a method of protection in Zones 1 and 2. In the case of pressure loss, an automatic shutdown of the power supply can occur even with a slight delay for Zone 1, while a visual or audible signal is sufficient for Zone 2.

The European and the American practices are quite similar. In fact, The European standards have been revised to include three new protection methods of px, py and pz. These methods are similar to the North American counterparts and show the level of harmonization taking place in the world. The safety devices (pressure sensors, flow meters, delay relays, etc.) needed to activate the alarm or the shutdown of the power supply must be either explosion-proof or intrinsically safe because, as a general rule, they are in contact with the explosive atmosphere both on the outside of the enclosure and on the inside during the expulsion phase or during pressure loss.

Sometimes the internal overpressure protection method is the only possible solution, for example, when no other method of protection is applicable. For example, in the case of large electrical apparatus or control panels where the dimensions and high-energy levels make it impractical to use an explosion-proof enclosure or the application of the energy limitation method, the internal overpressure protection method is often the only answer.

The use of pressurization is limited to the protection of apparatus that do not contain the source of an inflammable mixture. For this type of apparatus, such as gas analyzers, the continuous-dilution technique must be used. This technique always keeps the protective gas – air or inert gas – in a quantity such that the flammable mixture concentration never exceeds 25 % of the lower explosive limit of the gas present.

## Encapsulation

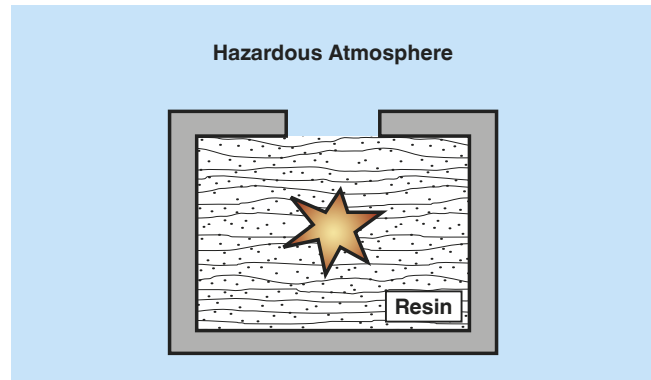

Figure 9 Schematic diagram of the cast enclosure (IEC 60079-18, EN 60079-18, UL 60079-18, FM 3600)

The encapsulation protection method is based on the segregation of those electrical parts that can cause the ignition of an explosive atmosphere in the presence of sparks or heating, by potting in resin that is resistant to the specific ambient conditions (refer to Figure 9).

Encapsulation ensures a good mechanical protection and is very effective in preventing contact with an explosive mixture. Generally, it is used to protect electrical circuits that do not contain moving parts, unless these parts, (e. g., reed relays) are already inside an enclosure that prevents the resin from entering. This technique is often used as a complement to other protection methods.

## Oil-immersion Protection Method

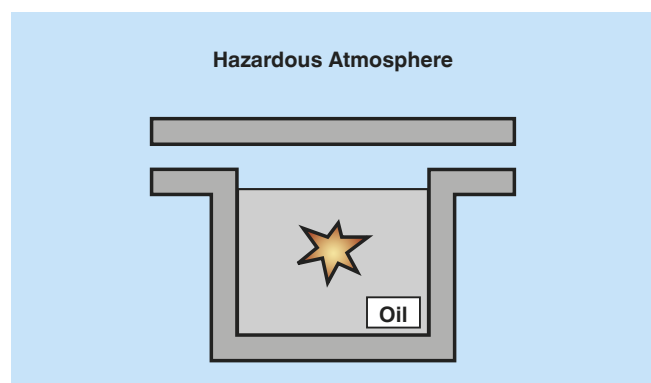

Figure 10 Schematic diagram of the oil enclosure (IEC 60079-6, EN 60079-6, UL 60079-6, FM 3600)

According to this protection method, all electrical parts are submersed in either nonflammable or low-flammability oil, which prevents the external atmosphere from contacting the electrical components. The oil often serves also as a coolant (refer to UL 698 and IEC 60079-6).

The most common application is for static electrical equipment, such as transformers, or where there are moving parts, such as transmitters.

This method is not suitable for process instrumentation or for apparatus that require frequent maintenance or inspections.

## Sand-filled (Powder-filled) Enclosure

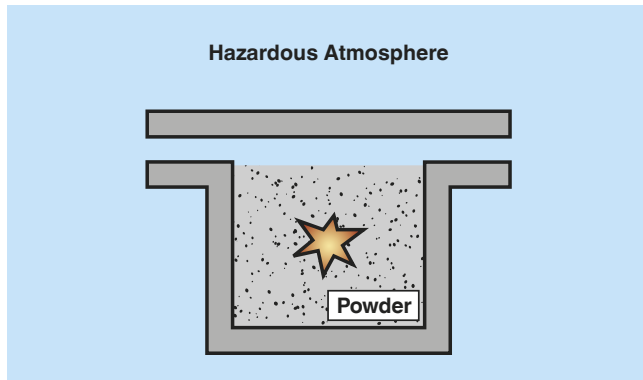

Figure 11 Schematic diagram of the sand enclosure (IEC 60079-5, EN 60079-5, UL 60079-5, FM 3600)

This protection method is based on spatial separation of the ignition source and the potentially explosive atmosphere. Electrical components which could ignite a potentially explosive atmosphere via sparks or heating are fixed in position within a housing and surrounded by a filling. The potentially explosive mixture may permeate the housing. A possible explosion of this mixture inside the housing would be extinguished by the filling before it can ignite the potentially explosive atmosphere surrounding the device. The filling must be accomplished in a manner so that there are no cavities in the filling material.

Normally the filling is quartz sand (glass beads). The filling is subject to special legal requirements, as is the design of the housing.

The free space inside the sand-filled electrical apparatus or Ex component must be completely occupied by filling material. The external surfaces of the housing may not reach the relevant minimum ignition temperature at any point.

The housing may not be opened and the filling must not escape from the housing, neither under normal operation, nor due to electric arcs or other processes within the sand enclosure.

Application: components giving rise to sparks or hot components, the function of which is not influenced by fine-grained filling material. Capacitors or transformers are typical applications, but also complex electronic components, such as computers and monitors which are used for controlling, operating and visualizing process data in hazardous areas (see Figure 11).

## Increased Safety

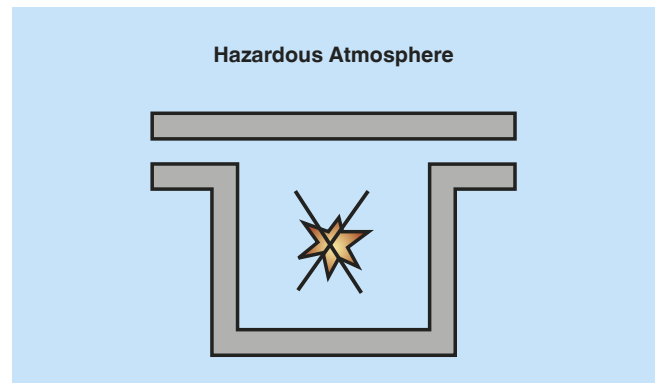

Figure 12 Schematic diagram of the increased safety ignition protection class (IEC 60079-7, EN 60079-7, UL 60079-7, FM 3600)

This protection method is based on the prevention concept. Measures must be applied to the electrical apparatus to prevent, with an elevated safety coefficient, the possibility of having excessive temperature or the generation of arcs or sparks inside and outside the apparatus during normal functioning (refer to Figure 11).

The increased safety ignition protection class is suitable for Zones 1 and 2. Under normal operation, an increased degree of safety is achieved by means of design parameters (increased air and creepage distances, degrees of protection to be observed, tensile strength of terminal connections and cable glands, minimum cross sections, mechanical strengths and isolation properties of the winding wire).

According to the standard, the prescribed means of construction must be made in such a way as to obtain an elevated safety coefficient during normal functioning. In the case of eventual allowed overloading, construction must comply to very specific standards regarding connections, wiring, components, distances in air and on surfaces, isolators, mechanical impact and vibration resistance, degree of protection of the enclosure, etc. Particular attention must be given to those parts of the apparatus that could be sensitive to temperature changes, such as motor windings.

In the event of an overload, cage motors, for example, can be shutdown promptly before the motor windings reach an impermissibly high temperature and become an ignition source.

Application: junction boxes and connection boxes, connection spaces for heating, transformers, ballast resistors, squirrel-cage induction motors, in combination with other ignition protection methods.

### Intrinsic Safety

Intrinsic safety is based on the principle of preventing an effective source of ignition. The electrical energy is kept below the minimum ignition energy required for each hazardous area.

The intrinsic safety level of an electrical circuit is achieved by limiting current, voltage, power and temperature; therefore, intrinsic safety is limited to circuits that have relatively low levels of power. Of critical importance are the stored amounts of energy in circuits in the form of capacitance and inductance. These energy storage elements must be limited based on the voltage and current levels present in a particular circuit or make-break component.

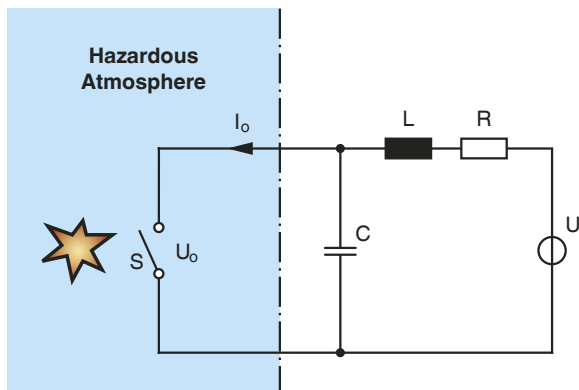

Figure 13 Schematic representation of an intrinsically safe circuit

In normal operation and in the event of a fault, no sparks or thermal effects may occur that could lead to the ignition of a potentially explosive atmosphere. Intrinsically safe circuits may therefore be connected and disconnected by experts during operation (even when live), as they are guaranteed to be safe in the event of a short circuit or disconnection. Intrinsic safety is the only ignition protection class that allows connectors to be opened and intrinsically safe apparatus to be removed and replaced by an equivalent device in a hazardous area. Because of the level of freedom this brings, intrinsic safety has become one of the most important methods of protection in the industrial automation industry.

### Installation Costs

The standard relative to intrinsic safety allows the installation of apparatus in a similar way to the practice used for standard apparatus. This factor alone lowers the cost of installation.

Explosion-proof, flame-proof, and pressurized enclosures require special devices, such as metal-clad cables, conduits, cable clamps, lead seals, etc. Purging, or pressurization also requires a pipeline for the protective gas. These are the principle reasons for the higher installation cost when these protection methods are used rather than intrinsic safety.

### Maintenance Costs

Relative to maintenance costs, intrinsic safety is the most advantageous because this method allows live maintenance with no need for plant shutdown. Intrinsic safety is also more reliable due to the use of infallible and de-rated components as prescribed by the standards.

Explosion-proof and flame-proof enclosures require that particular attention be given to the integrity of the coupling joints and cable entrance, which adds to the cost of maintenance over a period of time.

For pressurized enclosures, there is an added cost for the maintenance of the protective gas supply system and its relative piping.

### Conclusion

From the comparison of the three most widely used protection methods, it is evident that intrinsic safety, where applicable, is preferred for safety and reliability reasons. Intrinsic safety is also the most economical for installation and maintenance.

The use of intrinsic safety provides the best mix of an affordable system and safety requirements.

### Special Ignition Protection Classes

Ignition protection class n, for use on electrical apparatus in Division 2 and Zone 2 includes a number of various degrees of protection, some of which can be seen as simplifications of intrinsic safety and other ignition protection classes already presented.

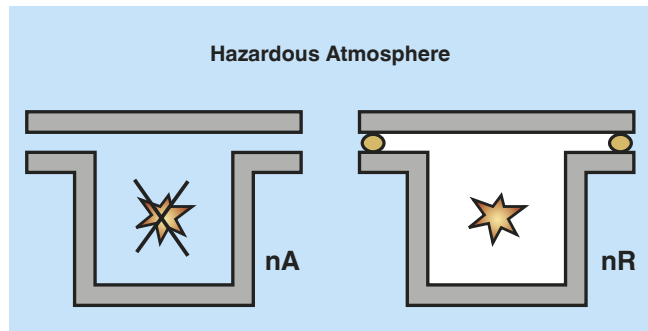

Figure 14 Schematic diagram of ignition protection class n (n = non-incendive) (IEC 60079-15, EN 60079-15, UL 60079-15, FM 3600)

Technology

Basic Principles

Applications

Ex Protection  
Intrinsic Safety

Functional  
Safety

Edition 912907 (US) / 220718 (EU) 06/2011

## Two Division Model

The concept of non-incendive circuitry is defined by the National Electrical Code, NFPA 70, as a circuit in which any arc or thermal effect produced, under intended operating conditions of the equipment, is not capable, under specified test conditions, of igniting the flammable gas, vapor, or dust-air mixture. To better understand the entire non-incendive energy concept, refer to ANSI/ISA S12.12.01 for further detail.

The non-incendive technique, when applied to electrical apparatus, makes the apparatus incapable of igniting a surrounding explosive atmosphere during normal functioning.

Non-incendive devices are not approved for Division 1.

## Three Zones Model

The European standard EN 60079-15 describes the requirements for equipment to be used in Zone 2. These include:

- Non-sparking electrical equipment
- Equipment with parts or circuits that require light arcs, sparks, or hot surfaces (and that could, therefore, be capable of igniting a potentially explosive atmosphere if they are unprotected).

Possible protective principles of ignition protection class n are summarized in the table below:

| Equipment n                               | Examples of protection methods   | Marking |
|---|--|---------|
| Non-sparking (simple "increased safety")  | Electro-motors (squirrel cage rotor), terminal box, fuses, lights, transformers, equipment with low power (C&I systems), plug-in devices, cells, batteries, etc.                             | Ex nA   |
| With protected contacts                   | Simple "flame-proof enclosure" or simple "cast enclosure"  | Ex nC   |
| Enclosed mechanism                        | Same   |         |
| Part not capable of igniting              | Contact mechanism or housing designed so as to prevent ignition  |         |
| Hermetically sealed construction          | Seal ensured by a melting process such as soft or hard soldering, welding, or melting glass into metal   |         |
| Sealed device                             | Designed so that it cannot be opened during normal operation   |         |
| Enclosed device                           | Completely embedded in an enclosing cast body  | Ex nR   |
| Restricted breathing                      | Housing design limits penetration of gases and vapors. Only sparking equipment with an internal temperature $\leq 10$ K compared to the ambient temperature of the housing can be installed. |         |
| Limited power (simple "intrinsic safety") | Limit power on circuits and components in accordance with the intrinsic safety concept   | Ex nL   |

Table 12 Possible protection principles of ignition protection class n

### Note:

nC, if molded, is now part of the protection method "encapsulation" mc (EN 60079-18).

nL is now part of the protection method "intrinsic safety" ic (EN 60079-11).

## Mixed Protection Methods

In the process instrumentation field, the use of several protection methods applied to the same apparatus is a common practice. For example, circuits with intrinsically safe inputs can be mounted in pressurized or explosion-proof enclosures.

Generally, this mixed system does not present installation difficulty if each of the protection methods is appropriately used and is in compliance with the respective standards.

## Summary of Protection Methods

This section has briefly presented the protection methods against fire and explosion. The concepts upon which these methods are based were introduced, and the general methods of construction and application were discussed.

The purpose of this section is not to exhaust the subject, but rather to offer an overview of the applicable protection methods for the electrical instrumentation used in that part of the plant classified as hazardous.

Intrinsic safety will be discussed in detail in the next section. For all other techniques, refer to the respective standards.

The following table presents a summary of the protection methods against explosion, stating the functioning principles from both the Two Division Model and Three Zones Model.

| General Principles    | Three Zone Model               | Zone    | Two Division Model                                | Division | Basic Features  | Defining Standard (IEC/EN) |
|-----------------------|--------------------------------|---------|---|----------|---|----------------------------|
| Explosion Containment | Flame-proof Ex d               | 1, 2    | Explosion-proof                                   | 1, 2     | Relatively simple to implement, however some mechanical requirements. Difficult/costly to maintain/test.  | EN 60079-1 (IEC 60079-1)   |
| Segregation           | Enclosed switch contacts Ex nC | 2       | Hermetic seal                                     | 2        | Protected contacts, usable for Zone 2/Division 2.   | EN 60079-15 (IEC 60079-15) |
|                       | Pressurization Ex px, Ex py    | 1, 2    | Purging   | 1, 2     | Can be used for large housing or workspaces. Requires special monitoring equipment.   | EN 60079-2 (IEC 60079-2)   |
|                       | Pressurization Ex pz           | 2       | Purging   | 2        | Similar to Ex px and Ex py but can only be used for Zone 2/ Division 2.   | EN 60079-2 (IEC 60079-2)   |
|                       | Encapsulation Ex ma            | 0, 1, 2 | Not recognized                                    | –        | Can be used for small components. Ensures good electrical and mechanical protection.  | EN 60079-18 (IEC 60079-18) |
|                       | Encapsulation Ex mb            | 1, 2    | Not recognized                                    | –        | Similar to Ex ma but can only be used for Zone 1 and Zone 2.  | EN 60079-18 (IEC 60079-18) |
|                       | Encapsulation Ex mc            | 2       | Not recognized                                    | –        | Similar to Ex ma but can only be used for Zone 2.   | EN 60079-18 (IEC 60079-18) |
|                       | Oil immersion Ex o             | 1, 2    | Oil immersion                                     | 1, 2     | Can be used for transformers and circuit breakers.  | EN 60079-6 (IEC 60079-6)   |
|                       | Restricted breathing Ex nR     | 2       | Not recognized                                    | –        | Can be used for housing used to prevent a gaseous atmosphere from entering.   | EN 60079-15 (IEC 60079-15) |
|                       | Powder filling Ex q            | 1, 2    | Not recognized                                    | –        | Can be used if there are no moving parts.   | EN 60079-5 (IEC 60079-5)   |
|                       | Increased safety Ex e          | 1, 2    | Not recognized                                    | –        | Can be used for apparatus that does not spark in normal operation (connecting devices, terminals, bulb sockets, motors). Special requirements for construction. | EN 60079-7 (IEC 60079-7)   |
| Prevention            | Non-sparking Ex nA             | 2       | Non-incendive equipment                           | 2        | Can be used for non-sparking devices with a low operating temperature.  | EN 60079-15 (IEC 60079-15) |
|                       | Intrinsic safety Ex ia         | 0, 1, 2 | Intrinsic safety                                  | 1, 2     | Ideal for process instrumentation. Simple installation, maintenance and testing during operation. Limited to low power, safe even if two faults occur.          | EN 60079-11 (IEC 60079-11) |
|                       | Intrinsic safety Ex ib         | 1, 2    | Not recognized                                    | –        | Similar to Ex ia, safe for one fault  | EN 60079-11 (IEC 60079-11) |
|                       | Intrinsic safety Ex ic         | 2       | (Associated) non-incendive Field Wiring Apparatus | 2        | Similar to Ex ia, safe in normal operation  | EN 60079-11 (IEC 60079-11) |

Table 13 Summary of protection methods against explosion

## Labeling of Explosion Protection Methods

### ATEX Labeling

With the introduction of ATEX requirements, a new labeling program came into force for the use of certain products in the EC.

The labeling requirements are aimed at uniformity. The CE conformity labeling on a product is an indication that all relevant directives (e. g. ATEX, low voltage directive 2006/95/EC, electromagnetic compatibility directive 2004/108/EC, machinery directive 2006/42/EC) have been adhered to and that the product for use corresponds to manufacturer's instructions.

For products used in hazardous areas, the following table is valid:

| Device group                 | Device category | Type of atmosphere       | Protection to be ensured | Hazardous area characteristics                                    | Zone comparison   |
|------------------------------|-----------------|--------------------------|--------------------------|---|-------------------|
| I (mining)                   | M1              | –                        | Very high                | Present continuously – equipment cannot be de-energized           | –                 |
|                              | M2              | –                        | High                     | Present continuously – equipment can be de-energized              | –                 |
| II (all areas except mining) | 1               | G (gases, vapors, mists) | Very high                | Present continuously, for long periods or frequently              | Zone 0<br>Zone 20 |
|                              |                 | D (dust)                 | High                     | Likely to occur in normal operation and for short periods of time | Zone 1<br>Zone 21 |
|                              | 2               | –                        | Normal                   | Not likely to occur in normal operation or infrequently           | Zone 2<br>Zone 22 |

Table 14 ATEX labeling

In the following example, the key elements of device labeling are listed:

 II (1) G [Ex ia] IIC PTB 00 ATEX 2080  
 II (1) D [Ex ia] IIIC



|                     |  | Symbol identifies the product for hazardous locations   |
|---------------------|---|---|
| ATEX portion        | II  | Device group – non-mining application   |
|                     | 1   | Device category – Can be used in Zone 0 and/or 20 – (...) indicates only part of the device meets the requirements of the category. |
|                     | G   | Atmosphere type – can be used in/for areas with flammable gas   |
|                     | D   | Atmosphere type – can be used in/for areas with flammable dust  |
| CENELEC/IEC portion | [...]   | Associated apparatus that supplies safety into the hazardous area.  |
|                     | Ex  | Product type – explosion protection   |
|                     | ia  | Protection type – intrinsic safety  |
|                     | IIC   | Equipment group – IIC (gas) is most hazardous area  |
|                     | IIIC  | Equipment group – IIIC (dust)   |
| Certificate details | PTB   | Certifying test agency  |
|                     | 00  | Test year (2000)  |
|                     | ATEX 2080   | Compliance with directive 94/9/EC<br>Registration number  |

Table 15 Device labeling

The Ex hexagon logo  indicates that this is a device for use in hazardous areas in the European market.

The EEx abbreviation stands for the CENELEC standard series EN 50\*\*\*. Since December 2004, the Ex abbreviation has stood for CENELEC standard series EN 60079-\*\*, which is based on harmonization with the IEC standard series of the same name.

### Division Model Labeling

A label must be placed on the device that indicates the Approval Type, Class, Division and Group used. On devices certified according to the two division model, reference to a control drawing or installation document is normally included on the product label.

Furthermore, using the NEC 505 zone model, a similar IEC-based ignition protection class and marking (incorporating the AEx symbol) is permitted in USA. However, according to article 505 of the NEC, the installation methods and electrical connections employed for zones are similar to the those used in article 500 of the NEC (i. e. conduit must be used). The exception to this requirement is when intrinsic safety is implemented.

|         |  |
|---------|--|
| NEC 500 | Class I, Division 1, Groups A, B, C, D, T6   |
| NEC 505 | Class I, Zone 1, AEx de IIC T6   |
| IEC     | Ex de IIC T6   |
| ATEX    |  II 2 G EEx or Ex de IIC T6 |

Table 16 Differences in labeling for NEC 500, NEC 505, IEC and ATEX

### Labeling of Associated Apparatus

#### Two Division Model

A label is placed on the device that indicates the approval type, class, division, and group used, and references a specific Control Drawing.

#### Example:

Associated apparatus for use in Class I, Division 2, Groups A,B,C,D hazardous locations provides intrinsically safe circuits for use in Class I, Division 1, Groups A,B,C,D hazardous locations when installed in accordance with Drawing No. ABC-1234.

#### Three Zones Model

##### Example 1: [Ex ia] IIC

Associated electrical apparatus located in a non-hazardous location

##### Example 2: Ex d [ia] IIC T4

Associated electrical apparatus in an explosion-proof enclosure located in a hazardous location

The marking between [ ] indicates that it is an associated electrical apparatus.



## The Philosophy of Intrinsic Safety

In the previous section, the different methods that are used to reduce the danger of explosion or fire were presented. The protection methods, based on the containment and segregation concepts, are methods that contain the explosion in order for the energy source – electrical or thermal – to avoid coming in contact with the potentially explosive mixture. In both cases, the use of appropriate enclosures and specific wiring and installation systems are required. The intrinsic safety method prevents the ignition of the explosive atmosphere, while simplifying the installation and use of the required apparatus that is connected to the electrical circuits directly located in a hazardous location.

## The Intrinsically Safe Circuit

According to article 504 of the National Electrical Code, NFPA 70 and IEC/EN 60079-11, an intrinsically safe electrical circuit is defined as one in which no spark or thermal effect generated during normal functioning and/or during specific fault conditions is able to ignite a given explosive atmosphere.

An electrical circuit typically consists of a voltage  $U$ , resistance  $R$ , inductance  $L$ , capacitance  $C$  and switch  $S$ , connected as shown below.

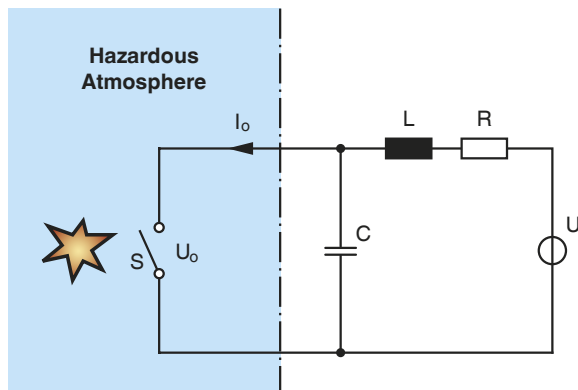

Figure 15 Schematic representation of an intrinsically safe circuit

In order to affirm that an electrical circuit is intrinsically safe, the parts of the circuit which are able to store energy, i. e., the inductor and the capacitor, must be considered. When the switch in the hazardous location is open, the capacitor accumulates energy that is discharged when the switch closes, thereby causing an electrical spark. In the same way, when the contact is closed, the inductor stores energy that is released in the form of an electrical arc when the switch opens. The energy that can be released by the circuit must be lower than the minimum ignition energy (MIE) of the air/gas mixture present in the hazardous location. Safety factors are then applied to ensure that the values allowed are well below that required for ignition.

A theoretical estimation of the energy inherent to an electrical circuit is not always possible, especially when the energy provided by the power source is higher, compared to the energy stored by the reactive components.

For this reason, the data normally used in considering intrinsic safety is presented in the form of the correlation between electrical parameters of the circuit, voltage and current, and the minimum ignition energy level of the hazardous atmosphere.

An electrical circuit, no matter how complex, is sequentially examined as resistive, inductive and capacitive. If the safety criteria are satisfied by the different types of circuits, the circuit can be considered intrinsically safe.

## Resistive Circuits

A circuit is considered as resistive when the reactive part, inductance and capacitance, is zero or negligible.

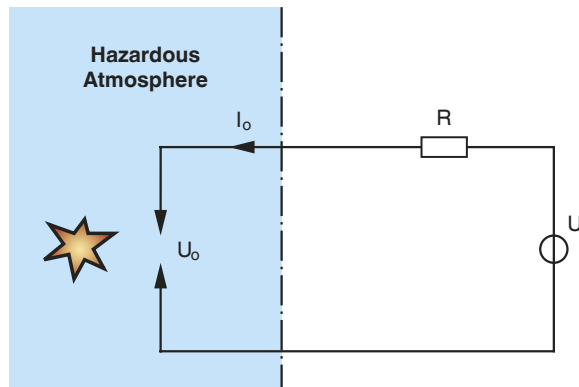

Figure 16 Schematic diagram of a resistive circuit

The energy released by this type of circuit depends essentially on the power supply source  $U$  and the current limitation due to the presence of resistor  $R$ .

The experimental tests on this type of circuit have demonstrated that the capacity for igniting an explosive atmosphere depends on the open-circuit voltage ( $U_0 = U$ ) and the short circuit current ( $I_0 = U / R$ ).

The ignition curve for resistive circuits relative to the group of gases that are considered by the standards is shown in Figure 17.

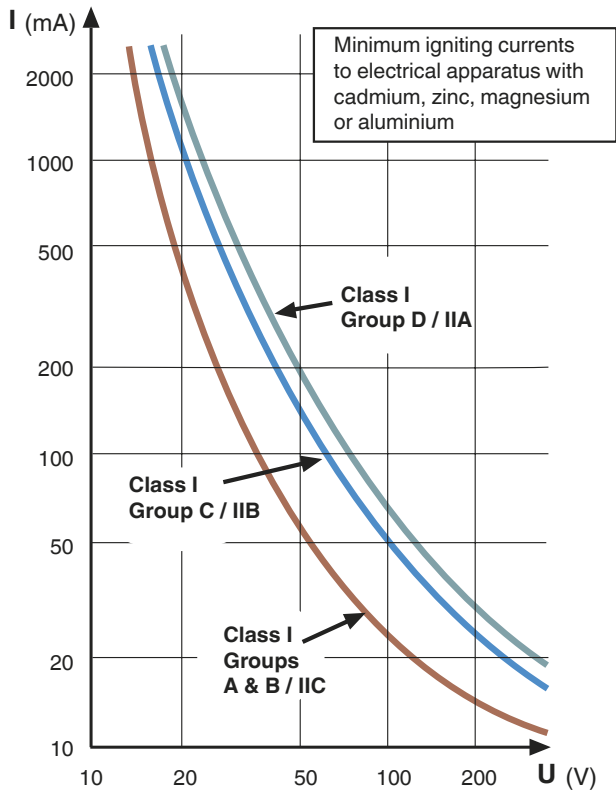

Figure 17 Ignition curve for a resistive circuit

By the trend of the curve, note that the lower the open-circuit voltage, the greater the amount of power that can be used safely. This characteristic allows process instrumentation that works with voltages on the order of 20 V to 30 V to be used efficiently in intrinsic safety applications.

For a more detailed ignition curve, refer to the appropriate standards.

### Inductive Circuits

An electrical circuit is inductive when the reactive part, due to its inductance, is high with respect to the resistive part.

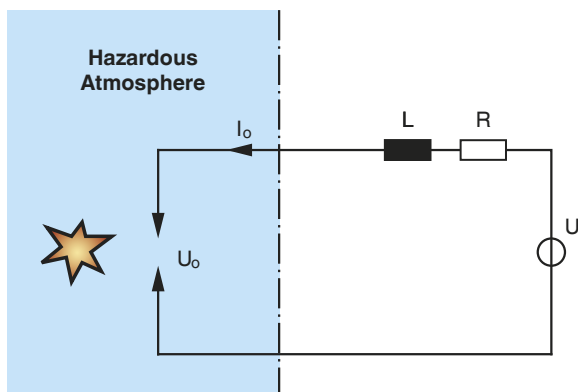

Figure 18 Schematic diagram of an inductive circuit

### Closed Electrical Circuits

The maximum current that circulates in a closed circuit is:

$$I_o = U / R$$

The inductor L stores energy in the amount of:

$$E = \frac{1}{2} \times L \times I_o^2$$

### Open Electrical Circuits

When the circuit is opened, a voltage ( $U_{ind} = L di / dt$ ) is induced at the ends of the inductor that is added to voltage U. Therefore, the energy stored in the inductive magnetic fields, plus the energy coming from the power source, is released in the form of an electric arc at the point of the circuit's opening.

If the inductor's stored energy is the only cause of the spark, the minimum ignition current for a certain hazardous atmosphere is bound to the L value according to the following relationship:

$$MIE = 1/2 \times L \times I_o^2 = \text{constant}$$

Graphic representation on a logarithmic scale should present a rectilinear trend with an inclination of -2.

From the graph in Figure 19, you will note that the relationship can be verified except when the inductor value is lower than, or equal to, 1 mH.

This is due to the fact that, for high currents and low inductor values, the circuit becomes resistive. In this case, the power supply source becomes predominant as energy is released by the circuit.

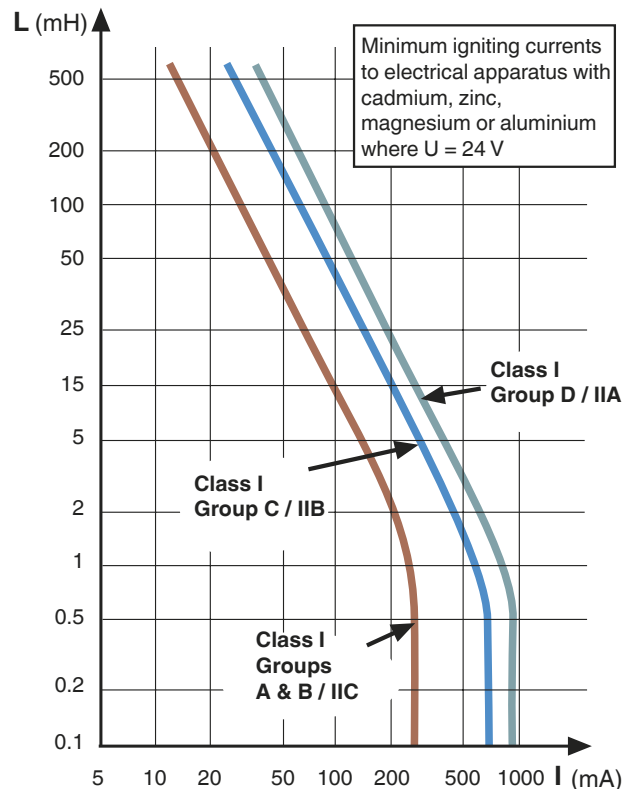

Figure 19 Ignition curve for an inductive circuit

Edition 912907 (US) / 220718 (EU) 06/2011

For a more detailed ignition curve, refer to the appropriate standards.

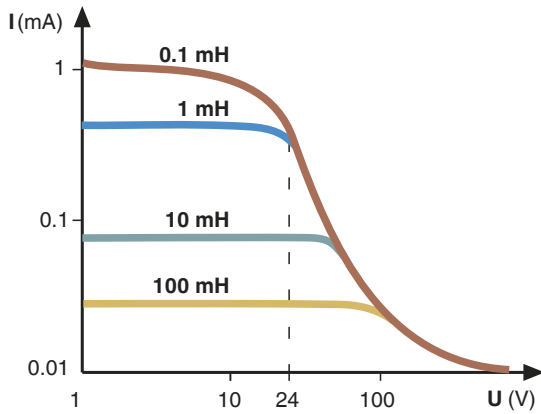

Figure 20 Minimum ignition current for inductive circuits in relation to voltage U

### Capacitive Circuits

When a capacitive circuit (Figure 21) is open, the capacitor charges to a voltage U and accumulates an energy ( $E = 1/2 \times C \times U^2$ ) that is released in the form of a spark at the point where the circuit closes. For an analogy with the inductive circuit with an inclination of -2 on the logarithmic scale, a relationship appears to exist between the capacitance value and the voltage source. However, experimental tests have demonstrated that this theoretical relationship does not exist and the ignition curves are as shown in Figure 22.

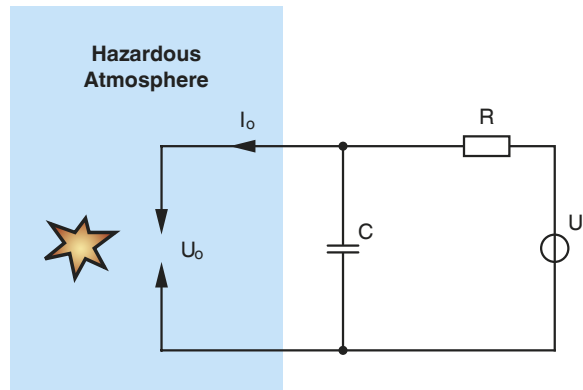

Figure 21 Schematic diagram of a capacitive circuit

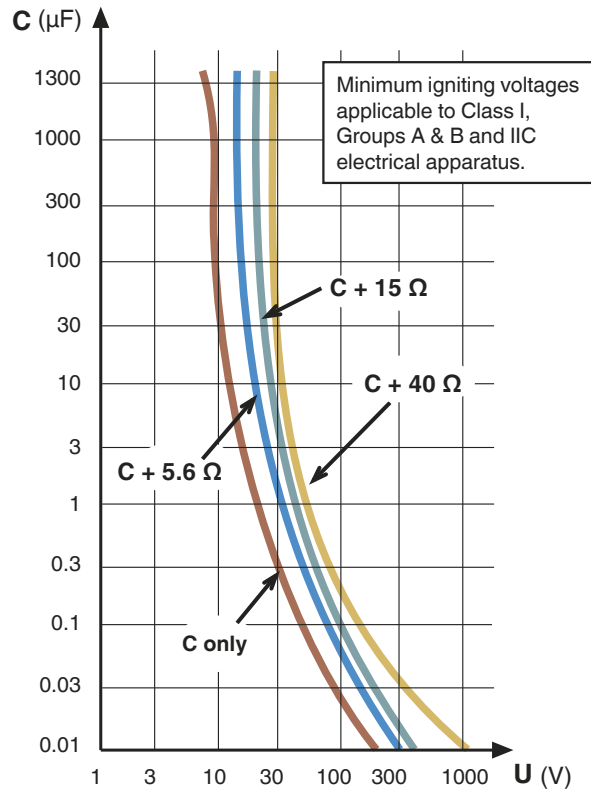

Figure 22 Ignition curve for a capacitive circuit

This discrepancy between the theoretical values and experimental data is due to the fact that the capacitor's discharge is not complete and instantaneous. Each resistor inserted in the capacitor's discharge circuit, besides increasing the discharge time constant, dissipates part of the accumulated energy, thus reducing the energy released at the point of contact.

Technology

Basic Principles

Applications

Ex Protection  
Intrinsic Safety

Functional  
Safety

## Intrinsically Safe Systems

Intrinsically safe apparatus never stand alone (unless they are battery operated). Generally, it is part of a system in which the certified components are used to guarantee the safety of the system.

The simplified schematic of an intrinsically safe system is shown in Figure 23 includes:

- Electrical apparatus (simple apparatus or intrinsic safe apparatus) located in a hazardous area
- Electrical apparatus located in a safe (non-hazardous) area
- The wiring between the two apparatus

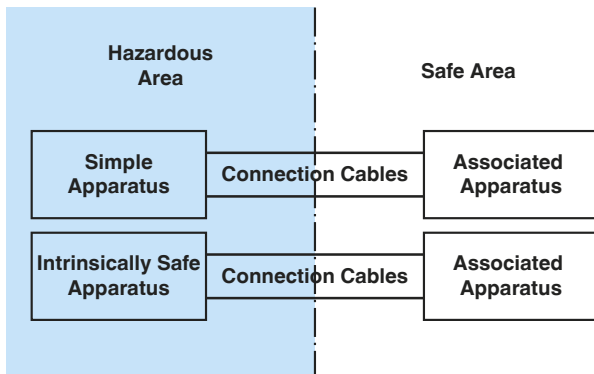

Figure 23 Simplified schematic of an intrinsically safe system

The analysis of an intrinsically safe system follows criteria that verify that the maximum energy, electrical and thermal, released in a hazardous location is lower than the ignition limit of the potentially explosive air/gas mixture, during normal or fault conditions.

## Hazardous Area Apparatus

Apparatus that are certified for use in hazardous locations are of two types – simple apparatus and intrinsically safe apparatus.

### Simple Apparatus

According to IEC 60079-11 the following shall be considered to be simple apparatus:

1. Passive components, for example switches, junction boxes, resistors and simple semiconductor devices;
2. Sources of stored energy consisting of single components in simple circuits with well defined parameters, for example capacitors or inductors, whose values shall be considered when determining the overall safety of the system;
3. Sources of generated energy, for example thermocouples and photocells, which do not generate more than 1.5 V, 100 mA and 25 mW.

## Intrinsically Safe Apparatus

The intrinsic safety of the apparatus must be guaranteed. This is accomplished by not permitting high energy levels, coming from connected apparatus or other circuits located in the same area, to be present in the hazardous location.

The certification exemption of simple apparatus cannot be applied to reactive circuits due to their capability of storing energy. Inductive components, relay coils or solenoid valves often can operate with energy levels much lower than the limits for intrinsic safety, but the energy released when the circuit is open can cause the ignition of the explosive atmosphere. In the same way, a capacitive circuit can cause ignition during discharge of the capacitor. Those types of apparatus must be equipped with components to reduce the released energy to safe levels.

There are many ways to make apparatus and circuits intrinsically safe. One such solution for making an inductive component safe is to parallel-connect a semiconductor diode to the coil so that released energy can be absorbed. For capacitive components, a resistor can be series-connected to reduce the discharged current to a safe level.

The standards permit the use of components such as diodes and resistors to be considered "infallible" where working conditions are concerned. Diodes must be duplicated and mounted so that a possible fault will not disconnect them from the coil. The resistor must be of metal film or wire-wound and of the necessary power rating. It must also be wired so that it will not short circuit during fault status.

These are just a few methods employed by designers to achieve the necessary protection for intrinsic safety apparatus.

## Parameters of Intrinsically Safe Apparatus

Electrical apparatus for hazardous locations must be approved as intrinsically safe. Normally, an intrinsically safe apparatus will have manufacturer's documentation, certificate, or control drawing that specifies parameters for the selection of the associated apparatus.  $U_i$  and  $I_i$  parameters are assigned to each input. The associated apparatus connected to each input must not have a maximum output voltage  $U_o$  greater than  $U_i$ . Similarly, the associated apparatus must not have a maximum output current  $I_o$  greater than  $I_i$ .

|       |                                      |
|-------|--------------------------------------|
| $U_i$ | Maximum voltage applied to apparatus |
| $I_i$ | Maximum current applied to apparatus |
| $C_i$ | Internal unprotected capacitance     |
| $L_i$ | Internal unprotected inductance      |

Table 17

## Connection Cables

The length of cable connecting intrinsically safe equipment with associated equipment may be limited because of the energy-storing characteristics of the cable. The manufacturer's documentation, certificate, or control drawing provides guidance on determining the maximum allowed capacitance and inductance.

The electrical parameters of an associated apparatus determine the maximum allowed inductance and capacitance values of the connected circuit; therefore, not only must the reactive part of the field devices be considered, but also the part related to the interconnecting cables. It is possible to limit or suppress the stored energy for field and non-hazardous location apparatus; however, because the total inductance and capacitance of the cable are distributed along its length, it is not possible to limit or suppress the stored energy for the connecting cable (refer to Figure 24).

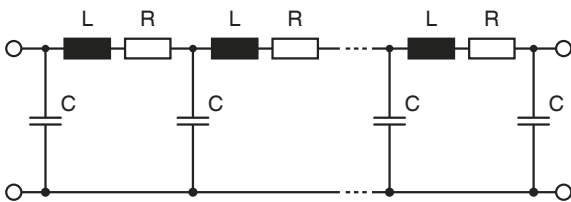

Figure 24 Equivalent schematic of a connecting cable

The capacitance, inductance, and resistance to length ratio parameters are usually supplied by the cable manufacturer and rarely cause a problem for the user. Particular attention must be given to the cable parameters because the manufacturer's data is not related to the possible fault situations covered by intrinsic safety. The fault combination that determines the worst condition must be verified.

For a 2-conductor cable, the manufacturer's data is sufficient. For shielded or multi-conductor cables, the analysis is more complex.

## Safe Area Associated Apparatus

Associated electrical apparatus, which are located in a non-hazardous location, consists of electrical circuits related to intrinsic safety and can be designed to limit the energy toward the hazardous location to the required level.

Associated apparatus can be of the following three types:

- Apparatus receiving signals from the field
- Apparatus sending command signals to the field
- Intrinsically safe interfaces

Instrumentation devices that receive signals from a hazardous location do not supply power to the field devices during normal functioning. Intrinsic safety is accomplished by limiting the energy in the case of a fault.

Instruments that send signals are designed so that the dangerous energy level is never exceeded during normal operation or under fault conditions.

Intrinsically safe interfaces (e. g., Zener Barriers) prevent the transfer of dangerous energy coming from the uncertified instrumentation in non-hazardous locations.

## Parameters of Associated Apparatus

Associated electrical apparatus must be certified as intrinsically safe, based on the maximum energy that can be transferred to the hazardous location, and have the following parameters:

|       |                               |
|-------|-------------------------------|
| $U_o$ | Maximum open-circuit voltage  |
| $I_o$ | Maximum short circuit current |
| $C_o$ | Maximum allowed capacitance   |
| $L_o$ | Maximum allowed inductance    |

Table 18

These parameters are very important for the intrinsic safety of a system. If the parameters are respected, ignition of the explosive atmosphere will be prevented, during normal operation or under fault conditions (i. e., accidental short circuiting, opening, or grounding of the connecting cable).

## Protection Levels of Intrinsically Safety Systems

### Zone Classification Protection Levels

Intrinsically safe electrical apparatus and the intrinsically safe part of the associated electrical apparatus are divided into three levels of protection – ia, ib, and ic.

- Level ia: An electrical apparatus belonging to level of protection ia must not be able to ignite an explosive atmosphere during normal functioning, during a single-fault condition, or during a combination of a two-fault condition with the following safety factors:
  - 1.5 during normal functioning,
  - 1.5 during normal functioning with one fault,
  - 1 with two faults
- Level ib: An electrical apparatus belonging to level of protection ib must not be able to ignite an explosive atmosphere during normal functioning or during a single-fault condition with the following safety factors:
  - 1.5 during normal functioning,
  - 1.5 during normal functioning with one fault
- Level ic: An electrical apparatus belonging to level of protection ic must not be able to ignite an explosive atmosphere during normal functioning.

In conclusion, safety is guaranteed for the apparatus of level of protection ia during a two-fault condition; safety is guaranteed for the apparatus of level of protection ib during a single-fault condition. For both levels of protection, the safety factor during normal functioning with one fault is 1.5.

Levels ia, ib, and ic can be used for any group of gas; however, level of protection ia is the only category permitted for Zone 0. This is justified by the fact that, according to the safety concept expressed in section "Ignition Triangle", there must be at least two independent events, each one of low probability, before the ignition can occur.

For Zone 0, where danger is ever present, level ia allows up to two non-sequential events. For Zone 1, where danger is intermittent, the two events are the simultaneous presence of the dangerous gas and a single-fault condition in intrinsically safe apparatus. For Zone 2, the area is normally not hazardous.

It is evident that apparatus designed for Zone 0, level of protection ia, can be used in Zones 1 and 2 with a greater margin of safety.

### Division Classification Protection Levels

In the United States, the competent authority for the classification of hazardous locations is the National Fire Protection Association (NFPA). The NFPA is responsible for the National Electrical Code, NFPA 70, and the American standard for intrinsic safety is ANSI/ISA-60079-11 Classification of Hazardous Locations.

Article 500 of the National Electrical Code stipulates the use of electrical apparatus in hazardous locations and defines the classification of the areas, the groups of potentially explosive material and surface temperatures.

ANSI/ISA-60079-11 is specifically related to intrinsic safety and is the authority on which the standards used by the testing labs are based (ANSI/UL 913, FM 3610). The requirements contained in ANSI/ISA-60079-11 are based on IEC 60079-11 with national deviations. This results in significant harmonization of requirements between North America and the IEC.

A hazardous location of Division 1 includes the corresponding Zone 0 and Zone 1. Therefore, only one intrinsic safety category is allowed with the following safety factors:

- 1.5 considering the most unfavorable condition of a single fault
- 1 considering the most unfavorable condition of two faults

The North American standard is equivalent to the European standard for category ia.

The certification of apparatus, as it relates to the present danger – gas, dust, fiber – and surface temperature, follows the same concept as the European classification. The differences lie with the denomination of the groups and the subclasses of temperature.

The ignition curve for the resistive, inductive, and capacitive circuits are identical to IEC 60079-11.

## Safety Barriers for Protection of Intrinsically Safe Circuits

Safety barriers are electronic circuits to limit the energy to the field within the minimum ignition level of the explosive atmosphere. In order to interface electrical apparatus located in a hazardous location with electrical apparatus located in a non-hazardous location (associated apparatus), defined barriers must be used.

Barriers can be of the following two types:

- Not galvanically isolated **Zener Barriers**
- Galvanically isolated barriers

### Zener Barriers

Intrinsic safety barriers of this type are uncomplicated from a circuitual point of view (refer to Figure 25).

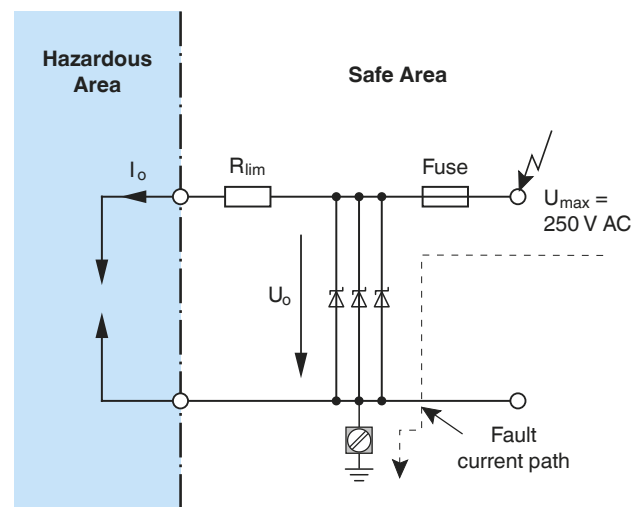

Figure 25 Schematic of a Zener Barrier

The functioning principle relating to this type of barriers is based on the following: If a dangerous voltage that comes from the safe area (250 V AC max.) is present, the zener diode limits the voltage and shunt the fault current toward ground until the fuse breaks, thereby maintaining an open-circuit "safe" voltage ( $U_o$ ) toward the hazardous location, while the maximum field short circuit current is defined by

$$I_o = U_o / R_{lim}$$

The safety parameters of Zener Barriers are defined in the following table:

|       |                               |
|-------|-------------------------------|
| $U_o$ | Maximum open-circuit voltage  |
| $I_o$ | Maximum short circuit current |
| $C_o$ | Maximum allowed capacitance   |
| $L_o$ | Maximum allowed inductance    |

Table 19

The efficiency of Zener Barriers in limiting the maximum energy to the hazardous location substantially depends on the integrity of the barrier ground connection. Installation rules require that the ground-connection resistance of the barrier must be lower than 1  $\Omega$ .

The main advantages of Zener Barriers are:

- Lower component costs
- Uncomplicated and reliable functioning
- More flexibility

The limitations of Zener Barriers are:

- The requirement of an equipotential ground system
- The existence of problems with current return caused by the absence of input/output isolation
- The reduction of the voltage available for the field apparatus caused by the limiting resistor, and the introduction of errors when the limiting resistor is connected to resistance temperature detectors
- The introduction of errors by the limiting zener due to the current leakage toward ground
- The requirement of active instrumentation for obtaining a signal, i. e., 4 mA to 20 mA, that is usable in non-hazardous locations when used with passive sensors, such as TCs, RTDs, etc.
- The possibility of permanent damage to the barrier in the case of a fault situation or an incorrect connection

### Isolated Barriers

Galvanically isolated barriers are transmitter power supplies, signal converters or repeaters that transmit or receive signals from hazardous locations in an isolated manner (refer to Figure 26).

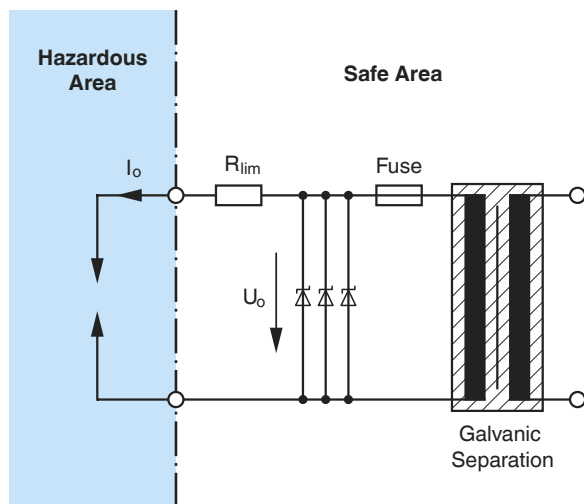

Figure 26 Schematic of a galvanically isolated barrier

The main difference between a passive Zener Barrier and a galvanically isolated barrier, lies in the safety components that are used to obtain the isolation between the non-hazardous location and the circuit related to intrinsic safety.

This configuration does not allow the dangerous voltage (250 V AC max) that may be present on the terminal blocks, which are located in a non-hazardous location, to be transferred to the energy-limiting circuit that must be able to tolerate, during a fault condition, the maximum voltage of the secondary side.

Since the entire circuit is floating in respect to ground, there is no possibility for the fault current, due to the 250 V AC, to pass through the energy-limiting circuit; therefore, it is not necessary to ground the energy-limiting circuit.

The safety parameters for isolated barriers ( $U_o$ ,  $I_o$ ,  $C_o$ , and  $L_o$ ) are determined in a similar way to the safety parameters for zener barriers. This is due to the similarity of the intrinsically safe circuits toward the hazardous location.

The main advantages of galvanically isolated active barriers are:

- A grounded system is not required.
- Grounded sensors can be used.
- Galvanic isolation avoids the problems of the return currents and allows a high common-mode rejection.
- Better measurement accuracy is possible.
- Output signals can be directly used.
- Designed and optimized for specific application.

The limitations of galvanically isolated barriers are:

- Higher component costs, although installed costs are more comparable.

## Proof of Intrinsically Safe Systems

### Systems with only one Associated Apparatus (Simple Proof)

In order to verify the intrinsic safety between the associated apparatus and the field device in the hazardous location, the safety parameters (i. e. entity parameters) must be matched. The voltage, current, power, capacitance, and inductance must be verified according to the following relationships:

| Safety/entity parameters     |   |             |                      |       |
|------------------------------|---|-------------|----------------------|-------|
| Intrinsically safe apparatus |   | Cable/leads | Associated apparatus |       |
| $U_i$                        |   |             | $\geq$               | $U_o$ |
| $I_i$                        |   |             | $\geq$               | $I_o$ |
| $P_i$                        |   |             | $\geq$               | $P_o$ |
| $L_i$                        | + | $L_c$       | $\leq$               | $L_o$ |
| $C_i$                        | + | $C_c$       | $\leq$               | $C_o$ |

Table 20 Electrical parameters of a simple intrinsically safe circuit

As an example, the test of a simple intrinsically safe circuit comprising a proximity switch and a switch amplifier should be carried out according to IEC/EN 60079-14, NEC NFPA 70 article 500 or CEC C22.1 as appropriate.

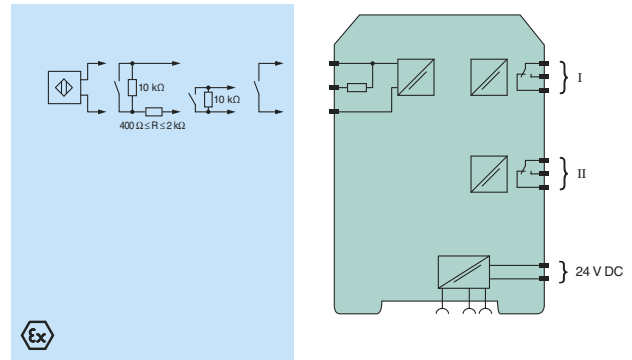

Figure 27 Intrinsic safety circuit to monitor position of a flap

| Associated apparatus |                | Manufacturer       | Relevant Certificate | $U_o$ [V] | $I_o$ [mA] | $P_o$ [mW] | $L_o$ [mH] | $C_o$ [nF] | Ex group |
|----------------------|----------------|--------------------|----------------------|-----------|------------|------------|------------|------------|----------|
| Designation          | Type           |                    |                      |           |            |            |            |            |          |
| Switch amplifier     | KFD2-SR2-Ex2.W | Pepperl+Fuchs GmbH | PTB 00 ATEX 2080     | 10.5      | 13         | 34         | 3          | 620        | IIC      |

| Serial no. | Intrinsically safe electrical apparatus |         | Manufacturer  | Relevant Certificate | $U_i$ [V]   | $I_i$ [mA] | $P_i$ [mW] | $L_i$ [mH] | $C_i$ [nF] | Ex group |
|------------|---|---------|---|----------------------|-------------|------------|------------|------------|------------|----------|
|            | Designation                             | Type    |   |                      |             |            |            |            |            |          |
| 1          | Proximity switch                        | SJ3,5-N | Pepperl+Fuchs GmbH  | PTB 99 ATEX 2219     | 16          | 25         | 64         | 1.25       | 50         | IIC      |
| 2          | Cable inductance and capacitance        |         | $L_c = 700 \mu\text{H/km}$<br>$C_c = 45.9 \text{ nF/km}$<br>$l = 600 \text{ m}$ |                      |             |            |            | 0.42       | 27.54      |          |
|            | Total inductance and capacitance        |         | $L_i/C_i$   |                      |             |            |            | 1.67       | 77.54      |          |
|            | Conditions for intrinsic safety         |         | $U_o$   | $\leq$               | $U_i$       | 10.5 V     | $\leq$     | 16 V       |            |          |
|            |   |         | $I_o$   | $\leq$               | $I_i$       | 13 mA      | $\leq$     | 25 mA      |            |          |
|            |   |         | $P_o$   | $\leq$               | $P_i$       | 34 mW      | $\leq$     | 64 mW      |            |          |
|            |   |         | $L_o$   | $\leq$               | $L_i + L_c$ | 3 mH       | $\leq$     | 1.67 mH    |            |          |
|            |   |         | $C_o$   | $\leq$               | $C_i + C_c$ | 620 nF     | $\leq$     | 77.54 nF   |            |          |

Table 21 Proof of intrinsic safety of a simple intrinsically safe circuit (example)

Typically, if safety or entity parameters are not available, a system certificate issued by a certification authority will be necessary to guarantee the intrinsic safety of the equipment.



### Systems with Several Associated Apparatus (Interconnected)

In the case of two or more associated apparatus in an intrinsically safe circuit, the following practical method can be used to determine the new maximum system voltages and currents under fault conditions in the intrinsically safe circuit using the values  $U_o$ ,  $I_o$  of each item of associated apparatus taken from the documentation or from the marking plate. Dependent on the interconnection of the intrinsically safe terminals of the associated apparatus, the values of  $U_o$  and  $I_o$  should be determined, in the case of normal operation and also under fault conditions, taking into account

- the summation of voltages only,
- the summation of currents only, or
- the summation of both voltages and currents.

In the case of series connection of the associated apparatus with galvanic isolation between intrinsically safe and non-intrinsically safe circuits only the summation of voltages is possible, irrespective of the polarity of the circuits.

In the case of parallel connection of both poles of the sources only the summation of currents is necessary.

In all other cases, where any interconnection of the poles of the sources is possible series or parallel connections have to be taken into account, dependent on the fault under consideration. In this situation, both the summation of voltages and the summation of currents have to be considered separately.

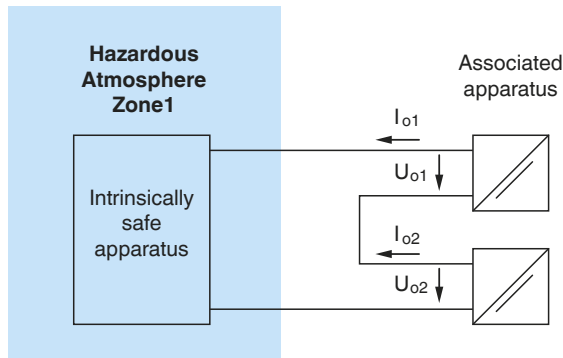

New maximum system values:

$$U_o = \sum U_{oi} = U_{o1} + U_{o2}$$

$$I_o = \max. (I_{oi})$$

Figure 28 Series connection – summation of voltage

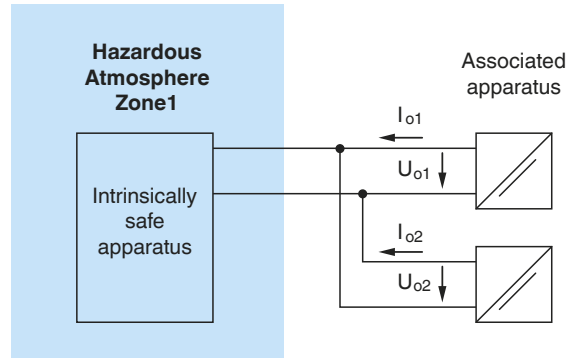

New maximum system values:

$$U_o = \max. (U_{oi})$$

$$I_o = \sum I_{oi} = I_{o1} + I_{o2}$$

Figure 29 Parallel connection – summation of current

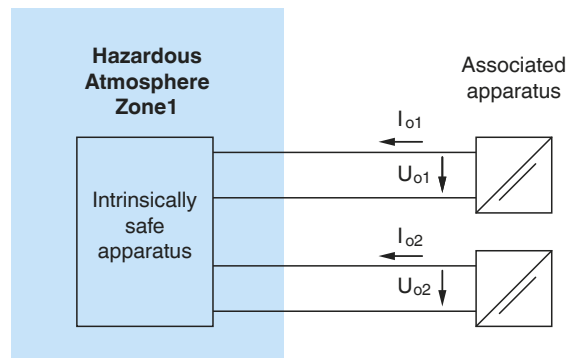

New maximum system values:

$$U_o = \sum U_{oi} = U_{o1} + U_{o2} \text{ or } U_o = \max. (U_{oi})$$

$$I_o = \max. (I_{oi}) \text{ or } I_o = \sum I_{oi} = I_{o1} + I_{o2}$$

Figure 30 Series and parallel connections – summation of voltage and current

## Installation of Intrinsically Safe and Associated Apparatus

Installation of intrinsically safe and associated apparatus must conform to IEC 60079-14, Article 504 of the NEC, section 18 of the CEC and other applicable standards. These standards require that intrinsically safe wiring be separated from non-intrinsically safe wiring, and that intrinsically safe wiring, terminals, and raceways be clearly labeled. Other considerations such as grounding and shielding requirements are also considered.

The installation of intrinsically safe and associated apparatus must be handled with particular care in order to prevent any intrusion in the intrinsically safe circuits from apparatus and conductors that are not intrinsically safe circuits, if these intrusions could reduce or eliminate the intrinsic safety of the system.

To achieve this, it is important to understand the concepts of segregation, separation, and clear identification of the intrinsically safe components. In particular:

1. The terminals of the intrinsically safe circuits must be placed at a distance of at least 50 mm (2 in) from the terminals of the non-intrinsically safe circuits, or adequate separators (e. g., grounded metal partitions) must be used.
2. The different types of intrinsically safe circuits do not have to be electrically connected, unless such connection has been specified in the control drawing or if the proof of intrinsic safety is verified.
3. When different types of intrinsically safe circuits end at the same marshaling terminal, it is advisable to maintain a distance between the relative terminals that is much greater than the 6 mm (0.24 in) required by the standard, unless it can be demonstrated that the interconnection between the different types of circuits will not introduce a dangerous energy situation.
4. The properties of intrinsically safe circuits are different if the circuits:
  - Operate at different voltages or polarities
  - Have different barrier grounding points
  - Are certified for different categories or for different gas groups

For the intrinsically safe circuit, installation must be performed so that the maximum allowed value for current and voltage can never be exceeded because of external electric or magnetic fields. For example, proper installation in this case requires the use of cables that are adequately shielded and are separated from the cables of other circuits.

The connection elements – terminal block housing, protective enclosures for cables, the external enclosures for single conductors, and the wiring between intrinsically safe apparatus and associated apparatus – must be clearly marked and easily identified. If a color is used for this purpose, the color must be light blue.

For devices such as terminal blocks and switches, additional certification or specific marking is not required.

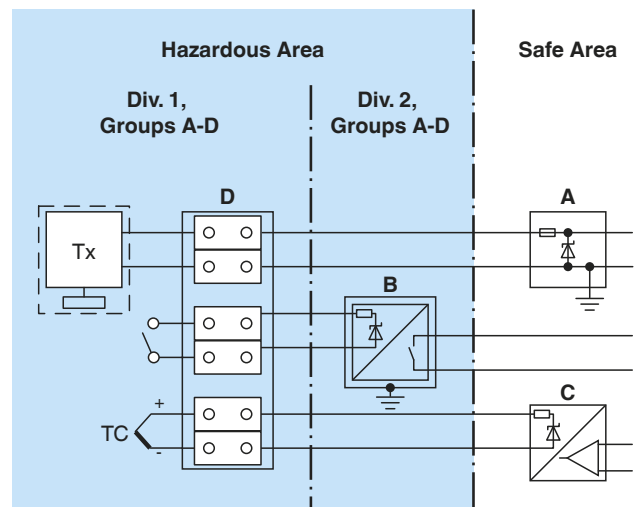

- A Zener Barrier
- B Switch amplifier
- C Converter
- D Terminal block for IS circuits

Figure 31 Example of different types of intrinsically safe circuits

## Protection Ratings for Enclosures

### Indoor Enclosures

Required by the standards for enclosures of intrinsically safe and associated apparatus, Type 1/IP20 is the minimum degree of protection for enclosures that are installed in indoor and/or protected areas. (refer to the "Additional Information" section for a detailed presentation of type and IP protection ratings).

### Outdoor Enclosures

For outdoor enclosures, a protection degree of Type 4 or 4X/IP54 is required. It is important to consider protection ratings of enclosures for intrinsically safe and associated apparatus in the context of the overall functionality and safety of the plant.

## Cable Capacitance and Inductance

When designing and installing intrinsically safe systems, keep in mind that capacitance and inductance parameters of the connecting cables are important factors, even if they are not always determining factors.

The capacitance and inductance values of the cable (generally, given in pF/m and  $\mu\text{H}/\text{m}$ ) should be easily available from the cable manufacturer. However, if there are difficulties in obtaining this data, the following values can be used (but only in an extreme situation), where the interconnection comprises two or three cores of a conventionally constructed cable (with or without shield): 200 pF/m (60 pF/ft) and either 1  $\mu\text{H}/\text{m}$  (0.2  $\mu\text{H}/\text{ft}$ ).

As an alternative to the inductance, another characteristic of the cable, the inductance/resistance ratio (L/R), can be used and is normally given in  $\mu\text{H}/\Omega$ . This parameter permits more flexibility in the cable installation process.

Refer to Figure 32 for examples of cable installation and to Figure 33 for examples of wiring in small enclosures containing associated apparatus.

**A** The cables of the intrinsically safe and non-intrinsically safe circuits are installed in two separate, isolated conduits.

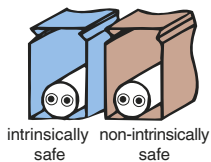

**B** The cables of the intrinsically safe and non-intrinsically safe circuits are installed in two separate, metallic, grounded conduits.

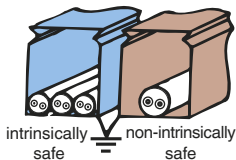

**C** The cables of the intrinsically safe and non-intrinsically safe circuits are installed in the same conduit. One of the cables is protected by a grounded shield to divert fault current to ground.

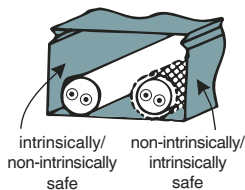

**D** Installation as above, but the cables are separated by anchor brackets. The distance d must conform to the standards with a minimum of 50 mm.

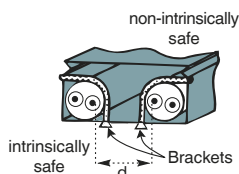

**E** Installation as above but the conduit must have an isolated divider.

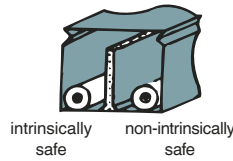

**F** Installation as above but the conduit and divider must be made of metal and grounded.

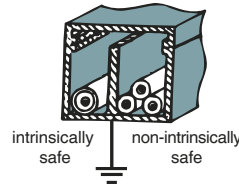
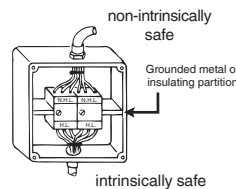
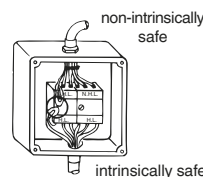

Figure 32 Examples of cable installation

**A** **Correct:** When installing the wiring as shown, the minimum required distance between intrinsically safe and non-intrinsically safe conductors is guaranteed.



**B** **Incorrect:** Several conductors are of excessive length.



**C** **Incorrect:** A separation does not exist between intrinsically safe and non-intrinsically safe conductors.

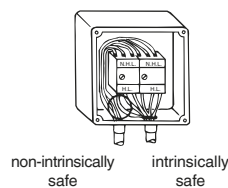

**D** **Correct:** The maximum distance between the lid and the separator must be less than 1.5 mm; or the separator must guarantee a distance in air around the lid of at least 50 mm between the terminals of the intrinsically safe circuit and the non-intrinsically safe circuit.

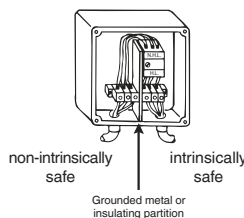

Figure 33 Examples of wiring in small enclosures containing associated apparatus

## Grounding of Intrinsically Safe Plants

Intrinsic safety standards require that certain points of the system must be grounded and others must be isolated from ground. Generally, the grounding of intrinsically safe circuits is required to prevent or even to reduce the probabilities that excessive energy levels can be generated in the hazardous location.

The isolation from ground of parts of the circuit is required to prevent the possibility of having two grounded points with a different potential and the possible circulation of a high current.

It is also a requirement of intrinsic safety that only one point can be grounded, while the rest of the circuit must be isolated from ground (500 V AC min).

The grounding of intrinsically safe circuits must be accomplished with a conductor that is isolated from any other plant grounds and connected to the reference ground system.

The NEC and CEC should be reference for North American installations while EN 60079-14 is used in Europe. Refer to the applicable standards for grounding practices in other countries.

## Grounding of Zener Barriers

From an intrinsic safety point of view, the effective functioning of Zener Barriers is linked to their capability of diverting to ground the dangerous energy coming from the non-hazardous instrumentation devices on which they are connected.

For this reason, it is very important that the ground connection of the Zener Barrier is made to an equipotential ground system (refer to Figure 34).

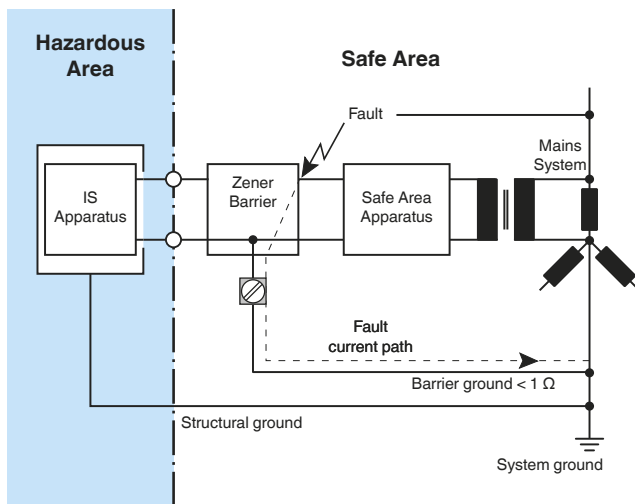

Figure 34 Schematic of a grounded Zener Barrier

The ground connector must be mechanically and electrically reliable and be able to reduce the fault current or the sum of the fault currents, if more barriers are connected to a single-ground bus.

The connecting cable used in grounding the barriers must be at least No. 12 AWG (American Wire Gauge) or  $2 \times 1.5 \text{ mm}^2$  (Europe cross-sectional requirement).

The allowed resistance between the ground terminal of the most distant barrier and the isopotential ground point must be less than  $1 \Omega$ .

Barrier ground connections must be separated from any other plant grounds and must be connected to a ground system at only one point.

The required condition of the only ground point implies that a Zener Barrier cannot be used on interfacing sensors or hazardous location apparatus containing grounded or poorly isolated circuits (i. e., thermocouples with grounded junctions or non-isolated transmitters).

## Grounding of Shielded Cables

The use of shielded cables for connecting the hazardous location sensors or transmitters with the non-hazardous location control and measurement apparatus is widespread.

From a functional point of view, the shield's purpose is to create an equipotential zone around the conductor's capacitive coupling with that of other conductors. This is only true if the shield is connected to a grounded reference potential.

The shield should be grounded at only one point – preferably, at the system's ground point. If the shield is grounded at two non-equipotential points, the current could circulate in the shield, preventing functionality. Therefore, a shielded cable must be provided with an extra isolating coat above the shield to prevent accidental ground contacts.

For intrinsically safe apparatus, the shield acts as another conductor between the hazardous and non-hazardous locations and could become the fault current route if the cable is damaged. From this point of view, the principle of isolating the circuit in hazardous locations and grounding it in non-hazardous locations can also be applied to the shield.

For passive-barrier applications, the shield can be locally grounded if the galvanic isolation is not damaged by this connection. This means that the two shields at the two sides of the isolation device must not be interconnected.

For applications where shielding is part of the segregation technique between different types of intrinsically safe circuits (i. e., multipolar cables), the reference ground connection of the shields must be the same as the ground connection of Zener Barriers (refer to Figure 35).

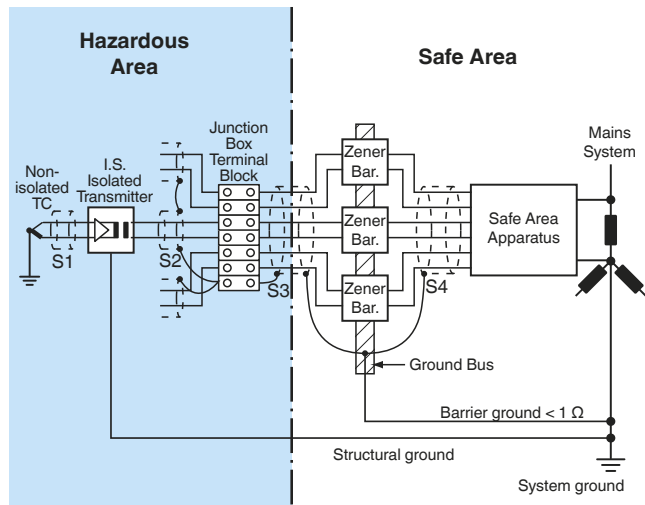

Figure 35 Example of shield ground connections

For functional reasons, the S1 shield is connected to the same grounding point as the measuring circuit. This must not be connected to the transmitter's metallic parts in order to prevent the second-circuit ground connection, which is not permitted by the intrinsic safety protection method.

Since the purpose of the field transmitter is to galvanically isolate the thermocouple's circuit from instrumentation in non-hazardous locations, there must be no connection between shields S1 and S2.

Shields S2 and S3 provide the shielding of the connection between the transmitter and the barrier. They are interconnected in an isolated point of the junction box terminal block.

S3 is also connected to the barrier's ground bus that, by means of a separate conductor, is connected to the reference ground point.

Shield S4 completes the shielding of the system and is not very important from a safety point of view. It is connected to the shield's reference point, which is represented by the ground bus.

For this type of connection, it is necessary that shield S2 be properly isolated from the transmitter's metallic structure; otherwise, a situation as shown in Figure 36 can occur.

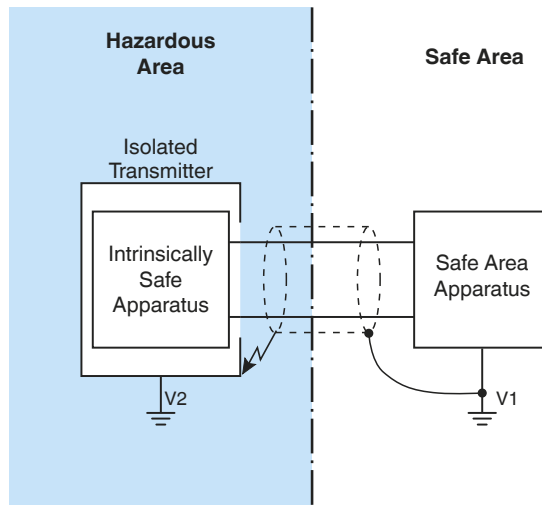

Figure 36 Possible dangerous situation for grounding of non-hazardous-location shields

When isolation no longer exists between the shield and the transmitter's enclosure, an excessive energy level could be present in a hazardous location if ground potential V1 is different from V2. Since the fault current is limited only by the resistance of the shield and the one existing between V1 and V2, the generated spark could ignite the surrounding potentially dangerous atmosphere.

This situation can be prevented by grounding the shield in the hazardous location; therefore, a spark could occur in the non-hazardous location without causing a fire or explosion.

Technology

Basic Principles

Applications

Ex Protection  
Intrinsic Safety

Functional  
Safety

## Legal Situation

In industrial countries explosion protection is regulated by law. Given any hazardous location installation, the plant operator is subject to the legal situation of the particular country. The following is a brief description of the North American situation followed by a more detailed situation for Europe.

### Legal Situation in North America

The United States and Canada have a set of National Standards in force for equipment relating to hazardous locations. The Standards Council of Canada and the Occupational Health and Safety Administration in the US indicate that hazardous location equipment shall be certified by designated, third-party agencies (Nationally Recognized Test Laboratories in the US) to the appropriate standards of safety. Compliance to the standards are verified by the approval agencies. After successful completion of product evaluation, the testing agent will authorize the use of their mark on the product as an indication of meeting the necessary safety standard. Installation of the equipment in the particular state or providence of use is covered by the appropriate installation standard (i. e. NEC and CEC) and verified by the **Authority Having Jurisdiction (AHJ)**.

### Legal Situation in Europe

The European Union has issued the ATEX directives (Atmosphere Explosive) which required the use of type-tested explosion-proof equipment.

ATEX consists of two parts: ATEX 95 (directive 94/9/EC), which concentrates on the duties of the manufacturer; and ATEX 137(directive 1999/92/EC), which focuses on the end user's obligations.

ATEX 95 applies to electrical as well as mechanical equipment and applies to gases, vapors, and dust atmospheres. Equipment manufacturers apply the harmonized explosion protection standards applicable in Europe and request an EC type test. Following successful testing, the testing institute issues a corresponding certificate (ATEX certificate) which is a prerequisite for bringing the equipment into circulation in the EC. Compliance with the ATEX directives means reinforced safety aspects – safer design, more demanding testing procedures, and specific quality assurance measures for the design as well as the manufacturing process.

With the signing of the Treaties of Rome (article 100: removal of technical barriers to trade), the foundation for harmonizing explosion protection on a European level was laid in 1957.

CENELEC (European Committee for Electrotechnical Standardization) emerged. With that, inside the EC and also beyond its borders (EFTA states and other countries), a unified legal basis for the manufacture and trade of electrical apparatus for use in hazardous areas was created. The installation conditions were subject to and are still widely subject to the legal and administrative regulations of the relevant countries using them.

CENELEC was originally composed of members of the European Economic Community (EEC). Today, CENELEC extends to almost 30 countries and many partner members.

Furthermore, CENELEC has decided only to enact standards in parallel with the IEC. This means in practice that European standards in the area of electrical engineering will only be based on IEC standards as harmonized EN standards or be newly drafted.

For explosion protection of electrical equipment, these are mainly standards of series EN 60079 which also cover the requirements of dust explosion protection.

The internationalization will be supported further by the introduction of the so-called IECEx scheme. The aim of the IECEx scheme is world-wide recognition, based only on a certificate and the associated test. In the future, manufacturers will not require further approvals for the entire global market. There is great interest in the implementation of this idea worldwide. More and more countries (already 31 in 2010) have declared their intention to participate and have begun to prepare legislative adaptations.

In recent years, two EC directives have fundamentally changed the European Ex-landscape:

- Directive 94/9/EC of the European Parliament and Council of 23 March 1994 for harmonization of the statutory provisions of member states for devices and protection systems for intended use in hazardous areas (ATEX 95).
- Directive 1999/92/EC of the European Parliament and Council of 16 December 1999 regarding minimum provisions to improve health protection and safety of employees who may be endangered by potentially explosive atmospheres (ATEX 137).

The ATEX 95 is mainly directed towards the manufacturers of electrical and non-electrical components and systems for hazardous areas and must literally be implemented in national law, while the ATEX 137 mainly applies to the safe operation of these plants. The minimum requirements of ATEX 137 had to be implemented in line with national law and each member state could largely implement its own workplace protection independently.

The goal of the EC is easy to recognize: on the one hand, to create equal competition for all suppliers in the EC single market and on the other hand, to create equivalent safety standards for all operators of installations and equipment within the EC.

The directive 94/9/EC prescribes an EC-Type Examination with a corresponding verification certificate (Ex certificate of compliance) for electrical devices of categories 1 and 2. To obtain this certificate, the manufacturer submits all technical materials and possibly a prototype to a notified body. On passing the test, an EC-Type Examination Certificate is issued, which contains all binding information and parameters for use in hazardous areas. This is the basis for operation and connection of several electrical devices in Ex Zones 0 and 20, as well as 1 and 21.

For category 3 devices (operation in Zones 2 and 22) an EC declaration of conformity regarding the compliance with the directive is sufficient.

The directive 1999/92/EC describes the "minimum requirements" for improving the health and safety of workers potentially at risk. It classifies the flammable atmosphere into zones and specifies which category of equipment is allowed for use in the zones.

The directive demands the analysis and description of the risks, the zone definitions and the required practices in relation to site safety. The effects of any explosion must be minimized in such a way that workers are not put at risk. Essentially, the employer is required to take all reasonable measures to prevent the formation of an explosive atmosphere in the workplace. Where this is not possible, measures must be taken to avoid the ignition of any potentially explosive atmosphere. In addition, the effects of any explosion must be minimized in such a way that workers are not put at risk.

The main obligations on employers

- Prepare an **Explosion Protection Document (EPD)**
- Classify the workplace into Zones where applicable
- Select ATEX 95 certified products (categories according to zone)
- Identify locations where explosive atmospheres may occur (using warning signs)
- Workers should be trained on hazardous area issues by the employer.
- Authorization should be given to each employee working in a hazardous area.
- When equipment is to be repaired, the end user has the responsibility to select a qualified repair shop.

Corresponding installations and equipment are classified as installations subject to monitoring in accordance with directive 1999/92/EC and may only be equipped with approved devices. In addition, installations must be tested before commissioning, following alterations and regularly by approved institutions, companies or by specially qualified personnel.

The responsibility for the plant safety is to the end user.

The safety of an Installation in a hazardous area is the result of cooperation between the equipment manufacturer, the installer and the end user. Under ATEX, the only parties responsible for preventing accidents due to explosive atmosphere are the equipment manufacturer and the end user. To use the equipment in a safe manner, the end user is obligated to follow the manufacturer's instructions regarding to installation, maintenance and repair for each piece of equipment.

The proof of intrinsic safety can be used to establish the safely limited energy values to ensure intrinsic safety. This proof is a component part of the documentation (a requirement of the European operating guidelines 1999/92 EC), which must be compiled before installation and kept up to date.

IEC/EN 60079-14 states that the requirements in the proof of intrinsic safety are adhered to if no system description exists for the overall intrinsically safe circuit. After establishing intrinsic safety the installer must then ensure that all required distances and separations between circuits are adhered to, especially with regards to the circuits being properly marked in accordance with IEC/EN 60079-14.

Obtaining proof of intrinsic safety is possible using several processes and depends on:

- the number of associated (supply) apparatus (one or more)
- shape of the output characteristic curve (linear or non-linear)
- type of reactances (lumped or distributed)

The following table provides an overview of the possible procedures for obtaining proof.

| Number of pieces of associated apparatus | Characteristic curve shape | $L_p, C_p$ both > 1 %<br>$L_o, C_o$ | Process                              |
|--|----------------------------|-------------------------------------|--------------------------------------|
| 1  | Linear                     | No                                  | Simple proof                         |
| 1  | Linear                     | Yes                                 | IEC/EN 60079-25 annex C or 50 % rule |
| 1  | Non-linear                 | Not relevant                        | IEC/EN 60079-25 annex C              |
| > 1                                      | All linear                 | No                                  | Simple proof                         |
| > 1                                      | All linear                 | Yes                                 | IEC/EN 60079-25 annex C              |
| > 1                                      | > 1 non-linear             | Not relevant                        | IEC/EN 60079-25 annex C              |

Table 22 Possible proof test procedures according to IEC/EN 60079-14 and IEC/EN 60079-25

The ignition limit curves can only be directly used to evaluate an intrinsically safe circuit and determine the maximum values for capacitance and inductance in the case of "simple proof" according to IEC/EN 60079-11 (EN 50020).

There are explosion limit curves for resistive, capacitive and inductive circuits.

Depending on which gas group an intrinsically safe circuit is being designed for, different curves are used to establish the minimum ignition energy for each gas group.

When both limits were pushed at the same time laboratory tests confirmed that ignition could occur.

In the example in Table 21 both the lumped inductances and capacitances are shown. This has already been factored into the certification of the associated apparatus through reduced  $L_o$  and  $C_o$  values. If these reduced values are not provided in the authorization then in the case of there being both lumped inductances and capacitances present the proof must be generated according to the IEC/EN 60079-25 annex C. In "simple" systems (only one source, output curve is linear) the "50 % process" from IEC/EN 60079-11 will suffice.

## Testing and Maintaining of Intrinsically Safe Systems

No method of protection is completely safe and human-error proof. Proper maintenance that includes a rigorous initial inspection, verification, and subsequent periodic inspections and repairs is extremely important for the safety and economical management of any instrumentation plant, and becomes fundamental in plants where the danger of fire or explosion exists.

To reduce the risk of catastrophic human errors, it is also important to permit only authorized and competent personnel to repair explosion-proof apparatus – as equipment must not be serviced under power. The following maintenance criteria are presented to give the reader a general understanding of what is involved in order to maintain an industrial facility relative to safety. This material is not intended to replace the applicable safety standards.

After the installation and completion of each plant, it is necessary to perform the following three types of inspection/maintenance activities:

- Initial inspection
- Programmed maintenance (periodic inspections and repairs)
- Apparatus failure and repairs

To maintain safety of electrical systems in hazardous areas regular maintenance is necessary.

Therefore the system operator is responsible for appropriate testing and maintenance cycles of their own system in accordance with the 1999/92/EC operator guidelines or other appropriate regulations.

For example, IEC/EN 60079-17 (testing and maintenance of electrical systems in hazardous areas) describes the procedure for electrical systems used in conjunction with explosion protection. The following applies in general:

Working on live electrical systems and apparatus in hazardous areas is strictly prohibited. Working on intrinsically safe systems is an exception to this rule.

Therefore special requirements exist for the intrinsic safety ignition protection class:

- Maintenance work on live intrinsically safe systems may be carried out under certain conditions.
- The ground connections of safety barriers may not be removed before the circuits in the hazardous area are disconnected.

Work in hazardous areas is to be limited to:

- disconnecting, removing, or changing parts
- adjusting all setting required for calibration
- removing or changing pluggable components
- using testing instruments as set out in the documentation
- After testing, the intrinsically safe system/apparatus must fulfill all requirements of the system documentation

The documentation must contain the following:

- proof of Intrinsic Safety
- manufacturer, type of apparatus and certification number, category, apparatus group, temperature class
- electrical parameters (inductance, capacitance, length, type and routing of cables, leads)
- special requirements according to the component data sheet
- The installation location of each component within the system

In addition the following should be tested:

- Easily identifiable marking of intrinsically safe circuits
- The conformity of the actual installation with the documentation
- Separation of components between intrinsically safe and non-intrinsically safe circuits
- Cables and leads and their shielding
- Continuity of grounding of non-galvanically isolated circuits, ground connections to ensure intrinsic safety
- Grounding or isolation of intrinsically safe circuits
- Adhering to specified minimum distances



## A new Dimension of Intrinsic Safety with DART

### Introduction

Intrinsic safety is a worldwide-accepted type of ignition protection that offers many advantages over other types of ignition protection. It is based on the principle that the energy released within an electrical circuit through sparks, heat, or other normal and abnormal events is incapable of igniting a potentially explosive atmosphere.

Intrinsic safety is currently achieved by limiting the available power. This limitation of power – usually to less than 2 W – provides intrinsic safety (Ex i) and is therefore mainly employed in the area of control and instrumentation in the power supply to actuators and sensors with low connected loads.

A significantly higher direct power with the simultaneous safeguarding of all the positive characteristics of intrinsic safety offers the user a new and essentially wider scope of application. These aims are achieved through DART technology (**D**ynamic **A**rc **R**ecognition and **T**ermination). DART is a means of instantaneous tripping, which dynamically detects an undesired condition or a fault in the electrical system precisely as it occurs and instigates an immediate transition to a safe condition before any safety-critical parameters are exceeded. DART is based on the detection of fault conditions and the characteristic rate of change of current.

Through the use of DART, systems can be operated at drastically increased direct power output compared to present intrinsic safety solutions. More available direct power opens the door to the use of intrinsic safety in many applications relevant to the process industry. The following are some examples: analytic equipment, weighing equipment, lighting systems, valve control systems and fieldbus systems such as FOUNDATION Fieldbus H1 and PROFIBUS PA.

### Basic Operating Principles

In the normal operating condition, the DART power supply feeds the full nominal power, which, depending on the application, can be greater by a factor of up to 25 (50 W) when compared to standards-related permissible values. At the very instant of the onset of a fault incident, such as the opening of the circuit, DART detects the resulting change in current and immediately switches off the power supply. In this way, the energy from the electrical system is effectively limited in just a few microseconds. Thus, a spark capable of causing an ignition is prevented.

This procedure is possible due to a very characteristic and therefore easily detectable change in current ( $di/dt$ ) during the onset of a fault condition. The reaction of the power supply takes place very quickly – in approximately 1.4  $\mu$ s. On such a fast reacting system, an additional factor to be considered is the propagation time on the cable. The energy released is determined by the power converted at the point of the fault integrated over the time up to the effective disconnection. The following physical parameters are principally responsible for this:

- The power – determined by the supply voltage and the load current
- The time – comprising the signal propagation delay in the cable and the reaction time of the power supply
- The energy stored in the connection cable
- The load behavior.

The energy liberated in the spark is determined by the power available, integrated over time. The relationships are explained below. Figure 37 shows the arrangement of the power supply, cable and devices in the hazardous area.

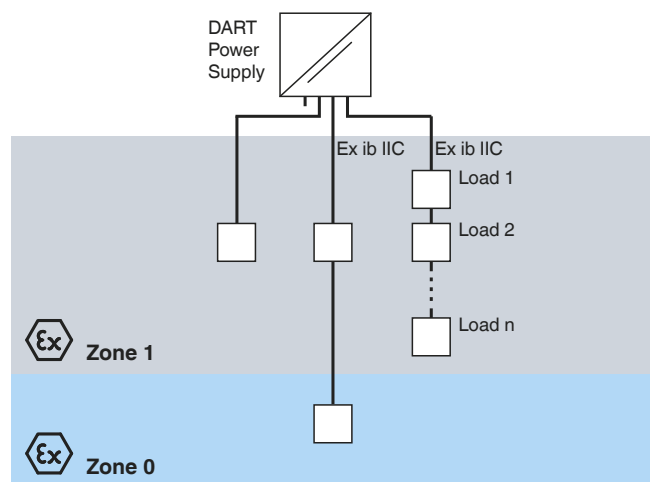

Figure 37 Arrangement of the power supply, cable and devices in the hazardous area

## Detecting the Ignition of a Spark

The determination of the intrinsically safe ignition limit values is made with the spark test apparatus specified in the standard IEC/EN 60079-11 – in which these values are subjected to a specified ignition probability. It is important to distinguish make sparks and break sparks. Only break sparks are considered in this context as they represent the critical case.

A typical example of the behavior of the electrical parameters of a break spark is shown in Figure 38. A break spark commences with the voltage  $U_F = 0$  V and usually ends on reaching the open circuit voltage at  $U_F = U_{\sigma}$ , in which the steady increase of the spark voltage is directly associated with a reduction in the spark current  $I_F$  in a linear circuit. The period of time in between depends on the circuit and is referred to as the spark duration  $t_F$ .

Typical spark duration  $t_F$ :  $5 \mu\text{s} < t_F < 2 \text{ ms}$ .

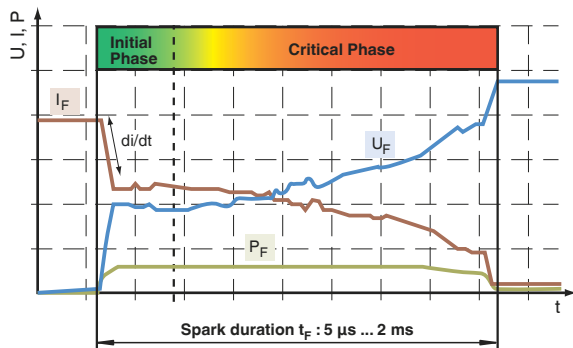

Figure 38 Variation with time of the spark current, voltage and power of a linear limited break spark (non-IS)

At the start of a break spark, the spark voltage  $U_F$  jumps within a very short time ( $t \leq 1 \mu\text{s}$ ) from 0 V to  $U_F \geq 10$  V. The voltage change is directly linked with a characteristic and easily evaluated sharp current change  $di/dt$  (see curve  $I_F$ ). Directly after this change in current, the spark current and spark voltage remain relatively constant for approximately 1 to 5  $\mu\text{s}$ . During this period there is definitely **no possibility of ignition** due to the extremely low available spark energy  $W_F$  and it is referred to as the "initial phase". The time following this initial phase persists up to the end of the spark duration  $t_F$ . This range is the "critical phase" during which **an ignition can occur**. During this period, the spark draws the necessary ignition energy from the system, i. e. from the source, the cable, and the loads.

From the knowledge of these variations, it can be shown that the rapid detection of sparks in combination with a means for the rapid disconnection of the source can be employed to reliably prevent the ignition of an explosive mixture. The task is principally to evaluate the current change ( $di/dt$ ), while giving consideration to the characteristic safety values.

Figure 39 shows the time history of a spark interrupted by a DART power supply. The current change is clearly evident and is used to trigger the transition of the circuit into the safe condition. It is clear, that with DART a fault condition is not only already detected and evaluated within the "initial phase", but that it also leads to the disconnection of the power supply. The switch-off time available during this process depends on the system. A frequently used value, based on the physics of the spark is 5  $\mu\text{s}$ .

Due to the very short rise times of current and voltage during the onset of a spark, the connecting cable between the power supply and the load acts as a wave guide even when the cable lengths are very short. The information that a spark is in existence propagates as a traveling wave or surge on the connecting cable. Thus, the power supply receives the information delayed – by up to one cable propagation delay period. The reaction of the power supply in turn becomes effective only after one cable propagation delay period and is based on the maximum cable length.

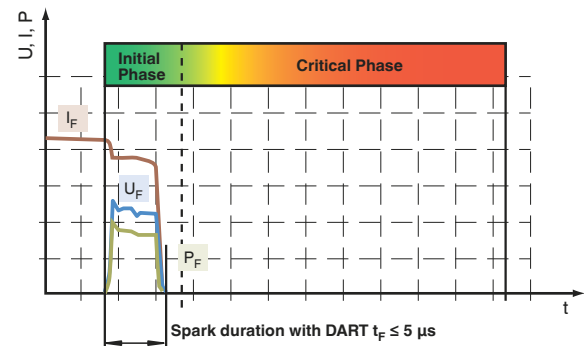

Figure 39 Time history of the spark current, voltage and power of a break spark with DART interruption

This delay is an important safety parameter. In a typical cable used for instrumentation, electric waves travel at approx. half the speed of light or 160000 km/s. Available power is approximately inverse proportional to the cable length. Further influencing factors to be considered are the stored energy in the connection cable and in the load.

### Function of DART Components

A DART power system is comprised of three components – the power supply, the connecting cable/s, and one or more loads. A system consists of only one source, which can be provided in a redundant form for reasons of availability. The loads are connected to the power supply via a connecting cable with a defined surge impedance.

#### Power Supply

The output voltage is galvanically isolated from the station supply and limited by multiple redundant circuits. The DART specific behavior is achieved through the functions represented in the block diagram in Figure 40.

Coordination of functions integrated in the DART power supply leads to the output characteristics, in which the output voltage  $U_{out}$  is represented against the output current  $I_{out}$  described below. In addition to the highest permitted safe values  $U_{lim}$  and  $I_{lim}$ , the characteristic is divided into the two operating ranges A and B:

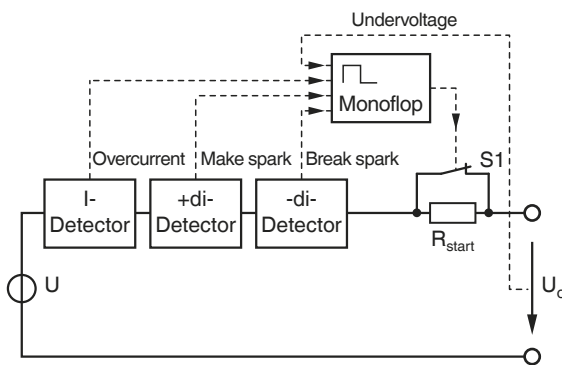

Figure 40 Block diagram of power supply

#### Safe Range A: Figure 41

This range, which is called the start-up and fold-back range, represents the characteristic curve of a linear voltage source with safe values. After switching on the source, switch  $S1$  is open (point 1). A very low current of a few mA, the "trickle current" (point 2) begins to flow across the internal current limiting resistor  $R_{start}$  and to the load resistance. The comparator circuit monitors the output voltage and in effect the combination of cable and load resistances to ensure no fault is present ( $R_{Load} > R_{L1}$ ). When the output voltage reaches or exceeds a fixed threshold value  $U_{thre}$  (point 3) and after a necessary safety period of approx. 3 ms, the source switches to range B, the operating range. However, this is only possible if the current variation  $di/dt$  due to the load lies below the prescribed detection threshold during the switch-on phase.

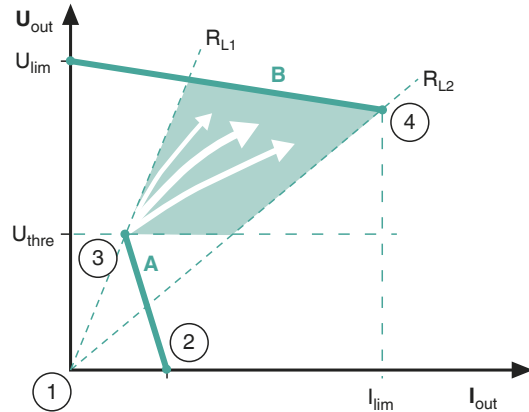

Figure 41 Output characteristic of a DART source with a representation of the transition from the safe range A to the optimum operating range B (Schematic representation)

#### Normal – Working Range B: Figure 42

Range B represents an almost ideal voltage source with an internal resistance  $R_i \approx 0 \Omega$ . In the operating range, the source can provide the optimum power to the load, by which means the maximum power conversion is possible at point 4 with  $R_{Load} = R_{L2}$ . Any variations in the load condition – including that due to faults – are associated with an immediate current variation  $di/dt$ . If the prescribed maximum value of the current variation is exceeded, the source switches off and the operating point returns immediately from range B to the safe fold-back range A. This likewise takes place if the maximum permissible load current  $I_{lim}$  is exceeded. (see point 4).

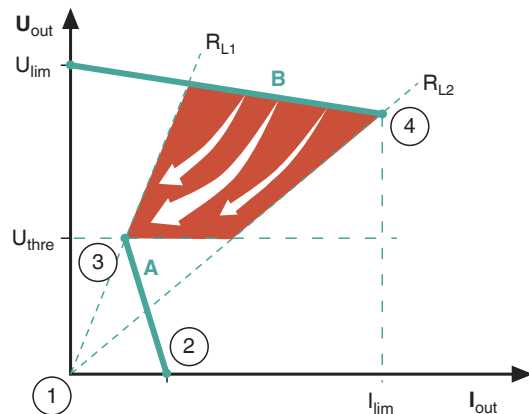

Figure 42 Behavior of the DART source in the event of a fault (schematic representation)

In summary, the dynamic control behavior of a DART source can be characterized as follows: a transition into the optimum operating range in the ms range and rapid turn-off to the safe fold-back range in the  $\mu s$  range in the event of faults.

Edition 912907 (US) / 220718 (EU) 06/2011

## Loads

The following prerequisites have been taken into account in the DART concept with regard to the loads:

The spectrum of loads that can be used should be as comprehensive as possible.

- It should be as simple as possible to integrate the loads into the system.
- It should be possible to operate already existing components / loads (including the customary field devices) with this technology in the same manner as is possible with previously customary technologies – e. g. FISCO (protection of stocks).
- In order to keep the safety considerations straightforward, only a line topology is envisioned.
- The loads must not have a negative influence either on the functional or the safety capability of the DART source or other loads (including the cable).

The following particularly applies to the loads: They must not restrict or absorb the propagation of information on the formation of sparks. In this context, the load behavior must be accepted as not being exactly defined. The following two examples illustrate safety-critical cases, which demand additional measures.

## Decoupling Module

A decoupling module ensures a well-defined electrical behavior both from a functional as well as a safety perspective. It permits operation of practically any load with DART. A decoupling module is integrated into the explosion-proof housing of the load and connected in series with it. The decoupling module essentially fulfills the following tasks:

- Soft start-up of the load with limited current rise (di/dt)
- Well-defined electrical behavior
- Optional disconnection in the case of faults through di/dt detection.

## Summary and Outlook

Due to DART, very high intrinsically safe power is available for new applications in the process industry, depending on the length of cable employed. The maximum possible power output is strongly dependant on the delay times on the transfer cable. Solutions exist for two application areas: DART power for maximum power output and DART for fieldbus, optimized for fieldbus applications.

| Output voltage $U_{out}$ | Active power $P_{out}$ | Cable length |
|--------------------------|------------------------|--------------|
| <b>DART power</b>        |                        |              |
| 50 V DC                  | approx. 50 W           | 100 m        |
| 24 V DC                  | approx. 22 W           | 100 m        |
| 50 V DC                  | approx. 8 W            | 1000 m       |
| <b>DART for Fieldbus</b> |                        |              |
| 24 V DC                  | approx. 8 W            | 1000 m       |

Table 23 Maximum intrinsically safe output values of DART at typical cable length

Suitable test methods have been developed for an exact safety evaluation of the energy-limiting behavior of dynamically operating power supply concepts. Changes to the currently applicable standards have already been investigated. Further steps will follow.

DART enables the use of intrinsic safety in applications with power requirements, which today necessitate other, typically inflexible or expensive types of explosion protection. By means of DART operating processes will become simpler and complexity is reduced. Operating safety will be increased.

## Application Practice

Depending of the plant topology, there are different possibilities for interfacing field devices with the centralized engineering station. For conventional wiring, zener and isolated barriers with intrinsically safe wiring to the field loops protect your plant. With a Remote I/O-System or a fieldbus infrastructure, the field wiring and also the amount of connections to the engineering station can be reduced. In this case, other aspects of explosion protection have to be considered.

In the following section, different mounting options for barriers, Remote I/O-Systems, or fieldbus infrastructure components will be discussed.

In the field, all kinds of devices can be connected to the interfacing products:

Two-wire transmitters, four-wire transmitters, contacts, optocouplers, NAMUR initiators, temperature sensors, frequency gauges, relay outputs, solenoids, lamps, indicators, sounders, LEDs, proportional valves, positioners, I/P converters, etc.

The signal transfer from or to the field device can either be conventional with digital or analog signals or also with digital fieldbusses. The physics of explosion protection is the same. Therefore the field devices in the following drawings are shown as neutral blue boxes.

## Zener and Isolated Barriers Applications

### Connecting IS Signals to Safe Area Mounted Devices

Isolated barriers and not-isolated Zener Barriers shown in Figure 43 are mounted in the safe area. They have an intrinsic safe wired connection (Ex i) to the field devices.

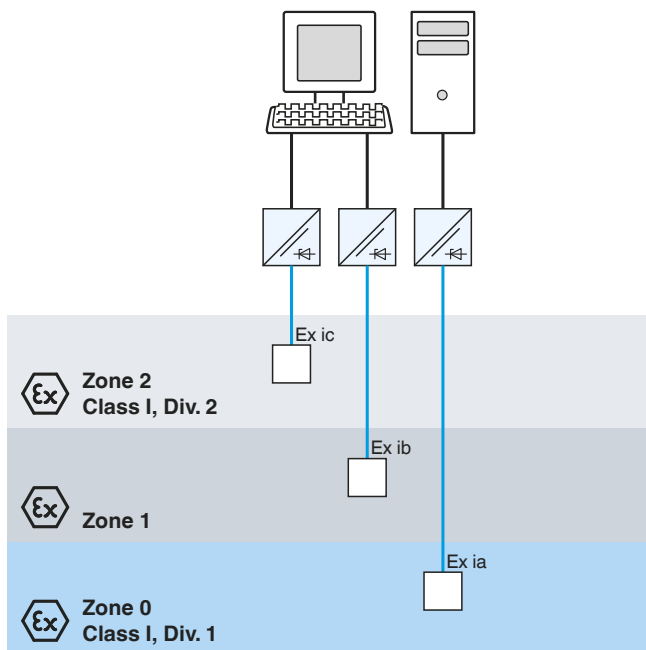

Figure 43 Connecting IS signals to safe area mounted devices

### Connecting IS Signals to Zone 2/Class I, Division 2 Mounted Devices

Isolated and not isolated barriers can also be installed in Zone 2/Class I, Division 2. On the field side all above mentioned field devices can be installed in Zone 2 up to Zone 0, Class I, Division 1, with the only restriction mentioned in the previous chapters. The field loops are intrinsic safety.

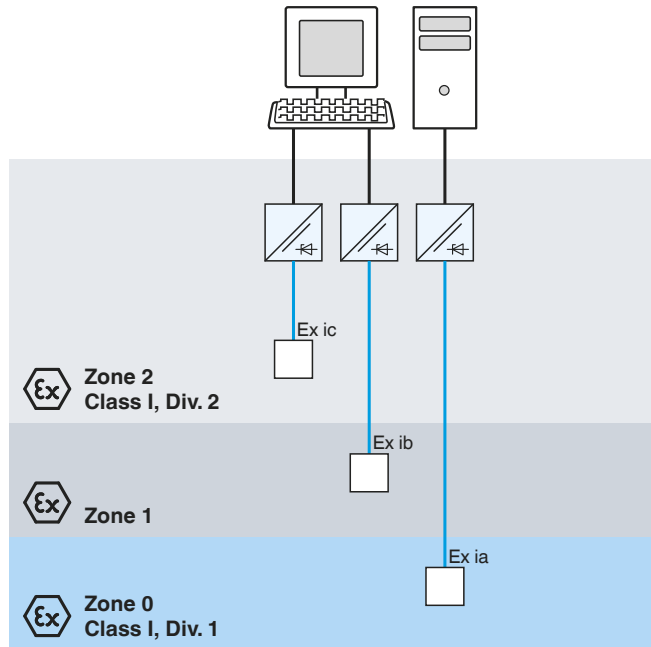

Figure 44 Connecting IS signals to Zone 2/Class I, Division 2 mounted devices

## Remote I/O Applications

### Connecting IS Signals to Safe Area Remote I/O

Standard RS 485 or Ethernet connect the control room with the field via Remote I/O. The Remote I/O employs various protection methods. IS modules can be exchanged under live operating conditions without a hot work permit. Inputs and outputs are galvanically isolated and intrinsically safe. The nA type has increased safety I/O optional. Field loops undergo IS loop proofing as in traditional IS interfacing.

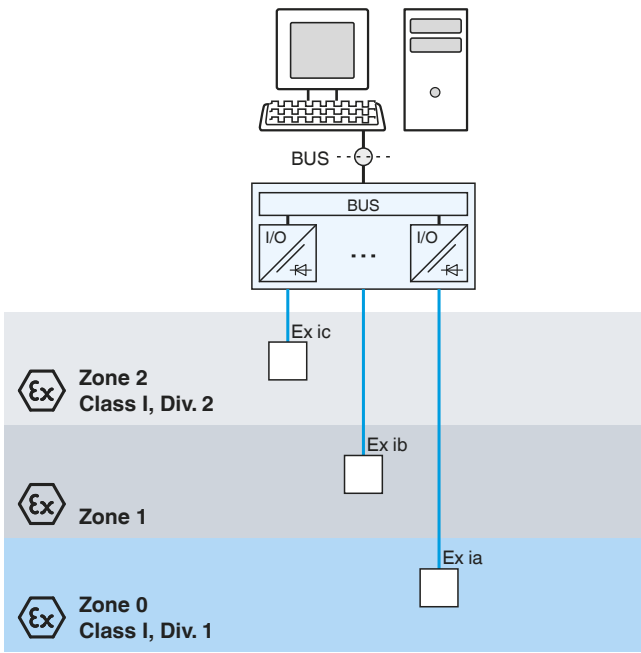

Figure 45 Connecting IS signals to safe area Remote I/O

### Connecting IS Signals to Remote I/O in Zone 2/Class I, Division 2

Standard RS 485 or Ethernet connect the control room to the hazardous area. The Zone 2/Class I, Division 2 Remote I/O employs various protection methods. IS modules can be exchanged under live operating conditions without a hot work permit under normal operating conditions. Inputs and outputs are galvanically isolated and intrinsically safe. The nA type has increased safety I/O optional. Field loops undergo IS loop proofing as in traditional IS interfacing.

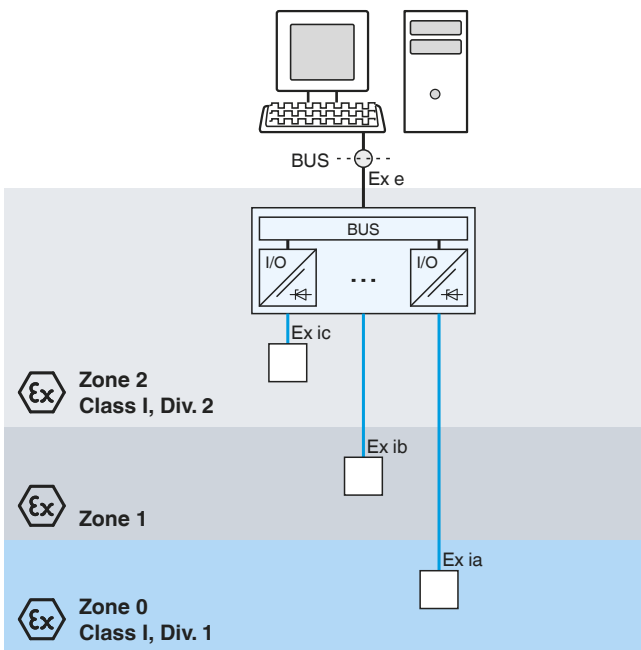

Figure 46 Connecting IS signals to Remote I/O in Zone 2/Class I, Division 2

### Connecting IS Signals to Remote I/O in Zone 1

Standard RS 485 or Ethernet connect the control room to the hazardous area. The final link in Zone 1 must feature an increased safety cable and connections. The Zone 1 Remote I/O employs various protection methods. IS modules can be exchanged under live operating conditions without a hot work permit. They are encapsulated for hostile and hazardous conditions. Inputs and outputs are galvanically isolated and intrinsically safe. Increased safety I/O optional. Field loops undergo IS loop proofing as in traditional IS interfacing.

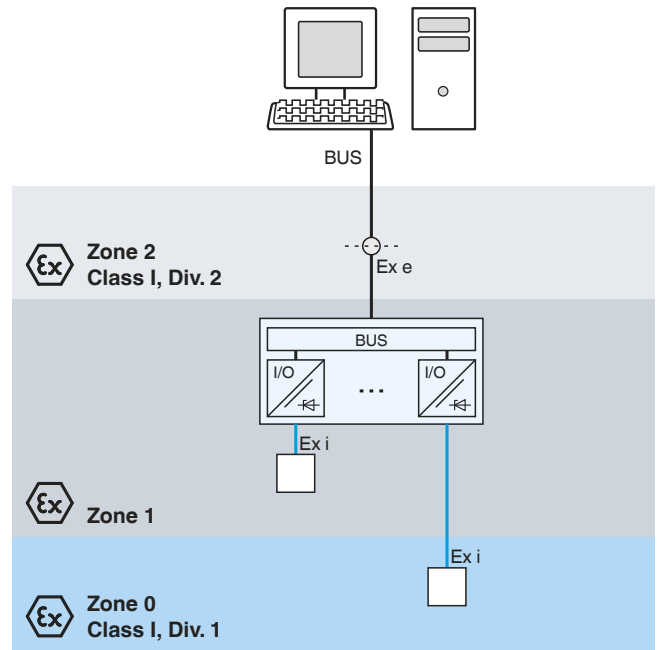

Figure 47 Connecting IS signals to Remote I/O in Zone 1

912907 (US) / 220718 (EU) 06/2011

Edition

## Fieldbus Infrastructure Applications

### Methods of Ignition Protection with Fieldbus

Fieldbus is a well accepted method to connect field instrumentation in process automation. Fieldbus systems accepted in process automation are defined in IEC 61158-2. They are: FOUNDATION Fieldbus H1 and PROFIBUS PA. They utilize the same physical layer for transmission of power and communication on a shielded twisted-pair cable. They are designed to meet the demanding criteria of hazardous area locations in process plants:

- Long cable distances of up to 1900 m
- Explosion protection
- Resistance to external influences, e. g. EMI

In fieldbus multiple devices are connected to a single electrical circuit, the segment. Users can choose from three basic methods of explosion protection based on requirements. Each method is described below and highlighted in its benefits

### Intrinsic Safety for the Entire Segment

Two methods, Entity and FISCO, are defined in IEC 60079. They are commonly accepted and can essentially be applied in any hazardous area location. This chapter describes the basic principles for applying and validating intrinsic safety with fieldbus. Regional requirements regarding installation methods apply.

### Entity Model

The Entity model as defined by IEC 60079-11 is a method of validating an installation of intrinsically safe and associated apparatus through the use of intrinsically safe parameters. In addition to the devices' parameters the cable capacitance and inductance is assumed as being concentrated and has to be considered as well. Simplifications for fieldbus were not considered within this specification and planners had no other option than to accept the complex and time consuming calculation efforts to validate an installation.

Applying the Entity model in practical fieldbus applications is rather rare, there are only few power supplies conforming to the Entity model available today. Typically they provide 10 V to 12 V and 70 mA to 100 mA which is just enough to operate 2 to 3 field devices per segment (gas group IIC). In the end Entity:

- Provides power for segments with up to 3 instruments
- Requires a calculation effort to validate intrinsic safety
- IIB solutions offer more power, however they are not suitable where as most applications require gas group IIC

### FISCO Model

Fast adoption of fieldbus technology in factory automation caused a desire to reevaluate the application of fieldbus in process automation as an alternative to 4 mA to 20 mA interface technology. Preliminary experiments conducted by the **Physikalisch Technische Bundesanstalt (PTB)**, Germany showed that long cable lengths connected to a power source did not significantly increase the incendivity of a spark. Under the premise to recheck the conservative approach of Entity with concentrated cable inductances and capacitances and with the objective to simplify system calculations and to allow more power in the field, PTB ascertained experimentally new IS parameters for fieldbus with the following objectives:

- Increase available power
- Standardize the installation parameters and limits
- Simplify system calculations and documentation

FISCO prescribes that only one power supply is permitted per fieldbus segment and that all other devices are power drains with measures in place preventing unintentional power feedback to the cable. For the first time a standard placed actual restrictions on cable and electric apparatus with regards to parasitic capacity and inductance. Instruments and power supplies require certification through a notified body. Cables are documented through a declaration by the manufacturer.

FISCO validation of intrinsic safety is limited to the documentation of FISCO compliance of all hardware involved. Later the FISCO report turned into the technical specification IEC TS60079-27 and adopted in the year 2005 as standard IEC 60079-27.

In spite of the improvements offered by FISCO a real breakthrough of intrinsically safe fieldbus failed to appear. This was due to the fact that the expected savings in installation cost and effort could not be realized, even if FISCO allows practically the operation of twice as many field instruments when compared to Entity. Further disadvantages moved to the foreground which haven't changed with the introduction of FISCO:

- No power supply redundancy, power supply as single point of failure
- Very little flexibility in segment design because mix of devices for safe and hazardous areas on one segment is not permitted.
- Operation of more field devices but still marginal compared to 32 possible devices as defined in the fieldbus standard IEC 61158-2.
- Need of special "add-on" devices for simultaneous use of FISCO and Entity field devices.

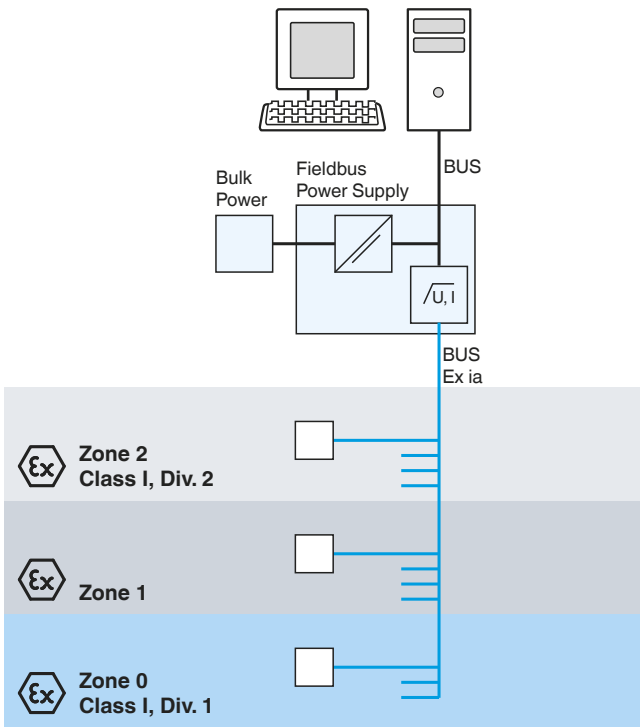

Figure 48 IS instrument connections with intrinsically safe fieldbus power supply

### IS Signal Connections with the High-Power Trunk Concept

The **High-Power Trunk Concept (HPTC)** removes the limitations with regards to segment length and number of devices. The principle idea of the HPTC is to deliver energy on the fieldbus trunk not limited for explosion protection close into the hazardous area. The trunk is installed utilizing increased safety methods (Ex e/Ex nA) and is therefore protected from mechanical damage and effects such as unintentional disconnect, damage or aggressive influences such as corrosion.

Within the hazardous area it is distributed via energy-limiting wiring interfaces to its final destination, the field instrument. Fieldbus coupler is the most generic name for a fieldbus wiring interface. A fieldbus coupler with energy limiting capabilities is installed near the instruments. From four to twelve instruments are connectable to outputs of the fieldbus coupler. The connection to the field instrument is called spur, as it is typically short – less than 120 m.

Compared to all other intrinsically safe installation methods standard power supplies can be applied for the HPTC, which are much simpler by design. The HPTC enables higher availability of the fieldbus segment as the power supplies may be operated in redundant configuration.

### High-Power Trunk Concept for Instruments Ex ia in Zone 0 to 1/Div. 1 to 2

For Zone 1/0 (Div. 1) applications the fieldbus coupler, typically called FieldBarrier is installed near the instrument and provides four outputs certified Ex ia IIC with galvanic isolation to the trunk. Each FieldBarrier output acts as independent FISCO or Entity power supply. Up to four FieldBarriers may be operated on one segment, allowing up to 16 IS field devices and an overall maximum cable length of 1900 m.

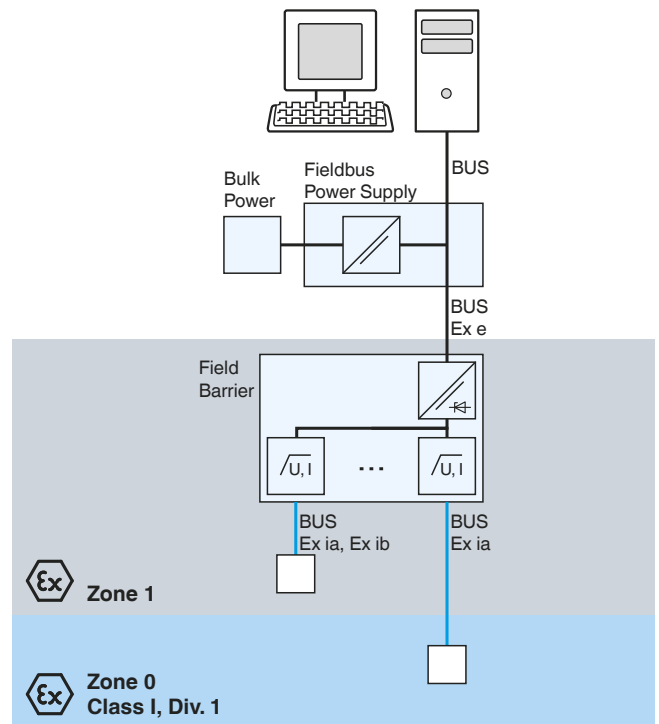

Figure 49 IS signal connections with High Power Trunk Concept using FieldBarriers in Zone 0 to 1/Div. 1 to 2

FieldBarriers provide:

- Galvanic isolation between the trunk and the segment
- Energy limitation of voltage and current for ignition protection Ex ia IIC

### High-Power Trunk Concept for Instruments Ex ic in Zone 2

In 2006 the 5th edition of the international standard IEC 60079-11 was released introducing intrinsic safety protection Ex ic for live workable circuits in hazardous area Zone 2. The existing standard IEC 60079-15 edition 3, defining energy limited circuits Ex nL, allowing live work on electronic circuits, will lose its validity approx. in 2011.

Fundamentally, the way how fieldbus segments are designed remains the same. Due to the fact that ic is part of the intrinsically safe standard, additional structural requirements to fieldbus equipment have to be considered. They are described in the application guideline "Using Pepperl+Fuchs fieldbus equipment in Zone 2 hazardous area Environments" available from Pepperl+Fuchs.



**High-Power Trunk Concept for Instruments  
Ex ic/Ex nL in Zone 2/Div. 2**

For Zone 2/Div. 2 applications the fieldbus coupler is typically called Segment Protector. Because of higher permitted energy levels and reduced demands on electronic design for energy limiting ignition protection, the required voltage and current limitation is separated.

- Voltage limitation is located in the fieldbus power supplies.
- Current limitation is located in the Segment Protector.

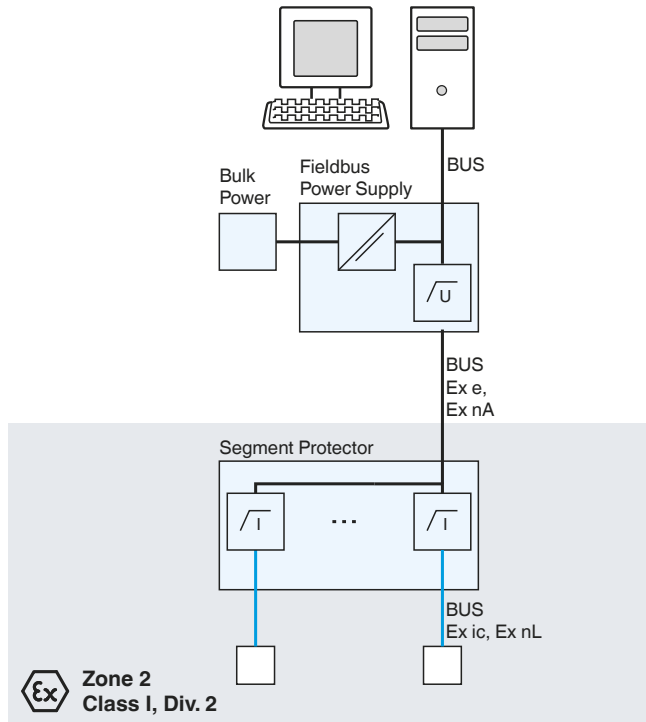

Figure 50 IS signal connections with High Power Trunk Concept using FieldBarriers in Zone 2/Div. 2

Only the proper combination of Fieldbus Power Supply and Segment Protector ensures proper ignition protection Ex ic or Ex nL at the spur. The trunk remains Ex nA: The High-Power Trunk. The following fieldbus designs are supported:

- No live maintenance, trunk and spurs rated "non-arcing, Ex nA"
- Live maintenance at the spur level (Ex nL), trunk rated "non-arcing, Ex nA"
- Live maintenance at the spur level (Entity Ex ic), trunk rated "non-arcing, Ex nA"
- Live maintenance at the spur level (FISCO Ex ic), trunk rated "non-arcing, Ex nA"

**Intrinsically Safe High-Power Trunk**

DART technology enables significantly higher direct power while maintaining intrinsically safe ignition protection with all the positive aspects it offers. DART is a means of instantaneous tripping when a fault in the electrical system occurs and a way to instigate an immediate transition to a safe condition before any safety-critical parameters are exceeded. DART is based on the detection of the current's characteristic rate of change when a fault occurs. DART Fieldbus is the first implementation of DART enabling the intrinsically safe high-power trunk concept.

**Trunk**

DART provides ignition protection intrinsic safety to the trunk. As practically all sparks are temporary, such as a disconnect operation of a DART Segment Protector the DART Power Supply will attempt to switch back on after only a few milliseconds. During this very short interruption the DART Segment Protectors power the field instrumentation – the availability of communication and power supply is ensured.

**Outputs**

The DART Segment Protector provides intrinsically safe outputs Ex ib IIC. Any instrument conforming to the Entity concept can be connected. That is more than 98 % of instruments available today.

DART Fieldbus enables the following aspects and benefits:

- Live working on trunk and devices without hot work permit
- Redundancy of power supplies with load sharing
- Longer cable runs and more devices (up to 1000 m, up to 32 devices)
- Reduced requirements for cabinet space
- Protection from short circuits at the spurs

More fundamental information and publications can be found on the website at: [www.technology-dart.com](http://www.technology-dart.com)

**Benefits of the High-Power Trunk Concept**

The introduction of the HPTC caused the break through and general acceptance of fieldbus in process automation. It is the enabling technology for fieldbus in hazardous areas, because it satisfies the need for long trunk cables while at the same time allowing a large number of devices per segment. The desired cost reduction in engineering, installation, check-out, and commissioning are achieved. With the HPTC the same topology can be used for all areas: non-hazardous, Zone 2, and intrinsically safe Zone 1, 0 applications.

Attributes enabled by the HPTC are:

- Highest possible overall cable length and at the same time largest number of field devices per segment
- Live work on field devices allowed without hot work permit
- Significantly lower requirements for cabinet space compared to FISCO-compliant supplies
- Easiest validation of intrinsic safety once per spur with no calculation required
- Mix and match of FISCO and Entity compliant devices on one segment
- Redundancy of the power supplies
- Integrated physical layer diagnostics for long-term monitoring

Edition 912907 (US) / 220718 (EU) 06/2011

## Additional Information

### Bibliography

- Bass, H.G., Intrinsic Safety, Quartermaine House, Ltd., Sunbury, Middlesex, UK, 1984.
- Calder, W., Magison, E.C., Electrical Safety in Hazardous Locations, Instrument Society of America, North Carolina, USA, 1983.
- Garside, R., Intrinsically Safe Instrumentation: a guide, Safety Technology, Ltd., Feltham, Middlesex, U.K., 1997.
- Magison, E.C., Electrical Instruments in Hazardous Locations, 4th Ed., Instrument Society of America, North Carolina, USA, 1998.
- Magison, E.C., Intrinsic Safety, Instrument Society of America, North Carolina, USA, 1984.
- Redding, R.J., Intrinsic Safety, McGraw-Hill, Ltd., Berkshire, UK, 1971.
- Dose, W. D., Manual Explosion Protection, Pepperl+Fuchs GmbH, Mannheim, 2007.

### Reference Standards

#### United States

- |               |  |
|---------------|--|
| ANSI/NFPA 70  | National Electrical Code, articles 500 to 505, Hazardous (Classified) Locations  |
| ANSI/NFPA 496 | Purged and Pressurized Enclosures for Electrical Equipment in Hazardous (Classified) Locations   |
| ANSI/NFPA 497 | Classification of Flammable Liquids, Gases, or Vapors and of Hazardous (Classified) Locations for Electrical Installations in Chemical Process Areas |
| FM 3610       | Intrinsically Safe Apparatus and Associated Apparatus for Use in Class I, II, and III, Division 1 Hazardous Locations                                |
| FM 3615       | Explosion-proof Electrical Equipment   |
| ANSI/UL 698   | Standard for Industrial Control Equipment for Use in Hazardous Locations, Class I, Groups A, B, C and D and Class II, Groups E, F and G              |
| ANSI/UL 913   | Standard for Intrinsically Safe Electrical Circuits and Equipment for Use in Hazardous Locations   |
| UL60950-1     | Information Technology Equipment – Safety – part 1: General Requirements   |

- |                                     |  |
|-------------------------------------|--|
| ANSI/ISA-60079-0 (12.00.01)-2009    | Electrical Apparatus for Use in Class I, Zones 0, 1, and 2 Hazardous Locations: General Information  |
| ANSI/ISA-60079-0 (12.00.01)-2009    | General Requirements   |
| ANSI/ISA-60079-11 (12.02.01)-2009   | Electrical Apparatus for Use in Class I, Zones 0, 1, and 2 Hazardous Locations – Intrinsic Safety i  |
| ISA-RP12.2.02-1996                  | Recommendations for the Preparation, Content, and Organization of Intrinsic Safety Control Drawings  |
| ISA-RP12.4-1996                     | Pressurized Enclosures   |
| ISA-12.04.01-2004 (IEC 60079-2 Mod) | Electrical Apparatus for Explosive Gas Atmospheres – part 2 Pressurized Enclosures p   |
| ANSI/ISA-RP12.06.01-2003            | Recommended Practice for Wiring Methods for Hazardous (Classified) Locations Instrumentation part 1: Intrinsic Safety                      |
| ANSI/ISA-12.12.01-2007              | Non-incendive Electrical Equipment for Use in Class I and II, Division 2 and Class III, Divisions 1 and 2 Hazardous (Classified) Locations |
| ANSI/ISA-60079-15 (12.12.02)-2009   | Electrical Apparatus for Use in Class I, Zone 2 Hazardous (Classified) Locations – Type of Protection n                                    |
| ANSI/ISA-61010-1 (82.02.01)-2004    | Electrical Equipment for Laboratory Use  |

#### Canada

- |           |   |
|-----------|---|
| C22.1     | Canadian Electrical Code  |
| C22.2-30  | Explosion-Proof Enclosures for Use in Class I Hazardous Locations                     |
| C22.2-157 | Intrinsically Safe and Non-incendive Equipment for Use in Hazardous Locations         |
| C22.2-213 | Non-incendive Electrical Equipment for Use in Class I, Division 2 Hazardous Locations |

**International**

|              |  |
|--------------|--|
| IEC 60079-0  | General Requirements   |
| IEC 60079-1  | Electrical Apparatus – Type of Protection d                              |
| IEC 60079-2  | Electrical Apparatus – Type of Protection p                              |
| IEC 60079-4  | Method of Test for Ignition Temperature                                  |
| IEC 60079-5  | Electrical Apparatus – Type of Protection q                              |
| IEC 60079-6  | Electrical Apparatus – Type of Protection o                              |
| IEC 60079-7  | Electrical Apparatus – Type of Protection e                              |
| IEC 60079-10 | Classification of Hazardous Areas  |
| IEC 60079-11 | Electrical Apparatus – Type of Protection i                              |
| IEC 60079-14 | Electrical Installations in Hazardous Areas (other than mines)           |
| IEC 60079-15 | Electrical Apparatus – Type of Protection n                              |
| IEC 60079-18 | Electrical Apparatus – Type of Protection m                              |
| IEC 60079-25 | Intrinsically Safe Systems   |
| IEC 60529    | Degrees of Protection Provided by Enclosures (IP Codes)                  |
| IEC 60950    | Information Technology Equipment – Safety – part 1: General Requirements |

**Europe**

|             |                                      |
|-------------|--------------------------------------|
| EN 60079-0  | General Requirements                 |
| EN 60079-1  | Flame-proof Enclosure d              |
| EN 60079-2  | Pressurized Apparatus p              |
| EN 60079-5  | Powder Filling q                     |
| EN 60079-6  | Oil Immersion o                      |
| EN 60079-7  | Increased Safety Protection Method e |
| EN 60079-11 | Intrinsic Safety Protection Method i |
| EN 60079-25 | Intrinsically Safe Systems i         |

**Internet Resources**

Instrumentation, Systems and Automation Association (ISA): [www.isa.org](http://www.isa.org)

American National Standards Institute (ANSI): [www.ansi.org](http://www.ansi.org)

Environmental Protection Agency (EPA): [www.epa.gov](http://www.epa.gov)

Occupational Safety and Health Association (OSHA): [www.osha.gov](http://www.osha.gov)

Technischer Überwachungsverein (TÜV): [www.tuvps.com](http://www.tuvps.com)

Factory Mutual (FM): [www.fmapprovals.com](http://www.fmapprovals.com)

Underwriters Laboratory (UL): [www.ul.com](http://www.ul.com)

Canadian Standards Association (CSA): [www.csa-international.org](http://www.csa-international.org)

National Electrical Manufacturers Association (NEMA): [www.nema.org](http://www.nema.org)

National Fire Protection Association (NFPA): [www.nfpa.org](http://www.nfpa.org)

European Committee for Electromechanical Standardization (CENELEC): [www.cenelec.org](http://www.cenelec.org)

International Electrotechnical Commission (IEC): [www.iec.ch](http://www.iec.ch)

## North American Enclosure Protection Ratings

Organizations such as NEMA, CSA, UL, IEC, and TÜV have developed rating systems for the identification of an enclosure's ability to withstand and repel the outside environment. NEMA, CSA, and UL are the systems most often used in North America.

The European rating system, developed by IEC and TÜV Rhineland, is very similar to the North American system for non-hazardous location enclosures. But because, historically, the European system has been more deeply rooted in the concept of intrinsic safety, IEC 60529 has no equivalents to the NEMA hazardous location enclosure types 7, 8, 9, and 10. The North American system also includes a 4X rating that indicates resistance to corrosion.

The following tables show the enclosure types for non-hazardous and hazardous locations according to NEMA standards and European IP rating systems.

| Type | NEMA National Electrical Manufacturers Association (NEMA standard 250)  |
|------|---|
| 1    | Intended for use primarily to provide a degree of protection against limited amounts of falling dirt.   |
| 2    | Similar to Type 1 but with addition of drip shields used where condensation may be severe.  |
| 3    | Intended for outdoor use primarily to provide a degree of protection against rain, sleet, windblown dust, and damage from external ice formation.   |
| 3R   | Intended for outdoor use primarily to provide a degree of protection against rain, sleet, and damage from external ice formation.   |
| 3S   | Intended for outdoor use primarily to provide a degree of protection against rain, sleet, windblown dust, and to provide for operation of external mechanisms when ice laden.   |
| 4    | Intended for indoor or outdoor use primarily to provide a degree of protection against windblown dust and rain, splashing water, hose-directed water, and damage from external ice formation.                                     |
| 4X   | Intended for indoor or outdoor use primarily to provide a degree of protection against corrosion, windblown dust and rain, splashing water, hose-directed water, and damage from external ice formation.                          |
| 6    | Intended for indoor or outdoor use primarily to provide a degree of protection against hose-directed water, the entry of water during occasional temporary submersion at a limited depth, and damage from external ice formation. |
| 6P   | Intended for indoor or outdoor use primarily to provide a degree of protection against hose-directed water, the entry of water during prolonged submersion at a limited depth, and damage from external ice formation.            |
| 12   | Intended for indoor use primarily to provide a degree of protection against circulating dust, falling dirt, and dripping non-corrosive liquids.   |
| 12K  | Type 12 with knock-outs.  |
| 13   | Enclosures are intended for indoor use primarily to provide a degree of protection against dust, spraying of water, oil, and non-corrosive coolant.   |

Table 24 Enclosure types for non-hazardous locations

| Type | NEMA National Electrical Manufacturers Association (NEMA standard 250)   |
|------|--|
| 7    | Intended for indoor use in locations classified as Class I, Groups A, B, C, or D, as defined in the National Electrical Code.            |
| 8    | Intended for indoor or outdoor use in locations classified as Class I, Groups A, B, C, or D, as defined in the National Electrical Code. |
| 9    | Intended for indoor use in locations classified as Class II, Groups E, F, or G, as defined in the National Electrical Code.              |
| 10   | Constructed to meet the applicable requirements of the Mine Safety and Health Administration.  |

Table 25 Enclosure types for hazardous locations

## Enclosure Protection Degrees (European Rating System)

### IEC Definitions

The IEC 60529 standard defines Ingress Protection as a two character code. The first character describes the degree of protection against access to hazardous parts and ingress of solid objects. The second character designates the Ingress Protection against water. Please refer to the appropriate sections of IEC 60529 for complete information regarding applications, features, and design tests.

### Notes:

Wherever a code number is not required, the letter X must be used in its place.

Devices having a second character of 7 or 8 do not need to fulfil the requirements of the second characters 5 or 6, thus, if the device fulfils both degree 6 and 7 against water, a double description must be used (e. g. IPX6/IPX7).

The conditions of Pepperl+Fuchs GmbH for IPX8 are:

- 1 m water column above the test subject
- 24 h operation under water with cyclical damping and amplification under rated load
- cycle time 2 h
- water temperature = room temperature ± 5 °C (± 5 K)

| IP | X<br>Protection against access to hazardous parts and ingress of solid foreign objects (first character)                               | X<br>Protection against ingress of liquids (second character)                   |
|----|--|---|
| 0  | • Non-protected  | 0 • Non-protected   |
| 1  | • Protected against ingress of objects equal to or greater than 50 mm<br>• Protected against access with back of hand (50 mm)          | 1 • Protected against ingress of water dripping vertically                      |
| 2  | • Protected against ingress of objects equal to or greater than 12.5 mm<br>• Protected against access with jointed finger (12 x 80 mm) | 2 • Protected against ingress of water dripping, enclosure tilted up to 15 °    |
| 3  | • Protected against ingress of objects equal to or greater than 2.5 mm<br>• Protected against access with a tool (2.5 mm)              | 3 • Protected against ingress of spraying water, up to 60 ° from vertical       |
| 4  | • Protected against ingress of objects equal to or greater than 1 mm<br>• Protected against access with a wire (1.0 mm)                | 4 • Protected against ingress of spraying water, any direction                  |
| 5  | • Dust protected<br>• Protected against access with a wire (1.0 mm)  | 4K • Protected against splash water with increased pressure                     |
| 6  | • Dust tight<br>• Protected against access with a wire (1.0 mm)  | 5 • Protected against ingress of jetting water, any direction                   |
|    |  | 6 • Protected against ingress of powerful jetting water, any direction          |
|    |  | 6K • Protected against strong water jets  |
|    |  | 7 • Protected against ingress of water during temporary immersion               |
|    |  | 8 • Protected against ingress of water during continuous immersion              |
|    |  | 9K • Protected against water on high pressure cleaning or vapor stream cleaning |

Table 26 Enclosure protection degree acc. to IEC/EN 60529

### Minimum Ignition Curves

The following graphs answer the question: What is a dangerous amount of electrical energy? These graphs are for circuits containing aluminum, cadmium, magnesium, or zinc – substances that produce a high temperature incendiary spark. It is important to keep in mind that these curves reflect the worst case scenario. When designing intrinsically safe electronic equipment today, most manufacturers start by specifying the equipment for the worst possible case.

The graphs chosen are those that are used most often by designers and manufacturers of electrical apparatus.

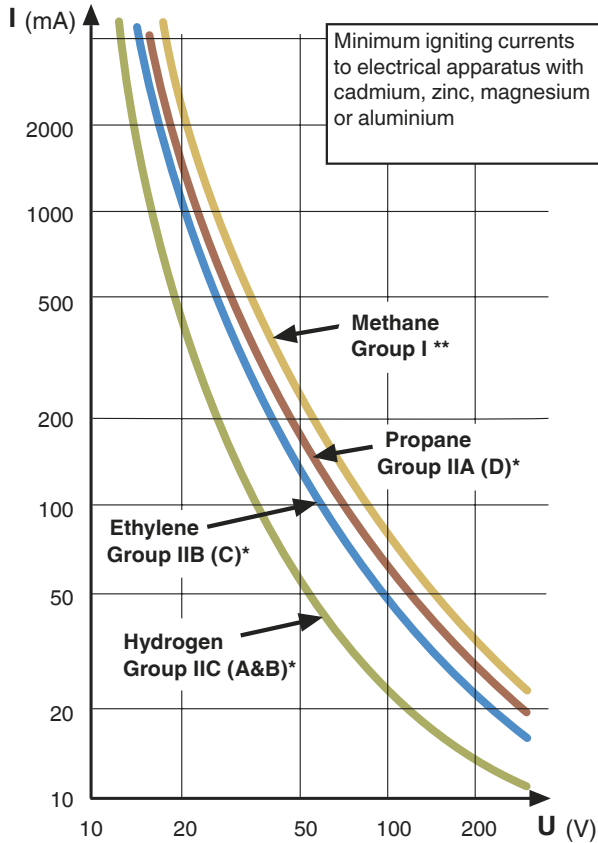

Figure 51 Minimum ignition curves for resistive circuits

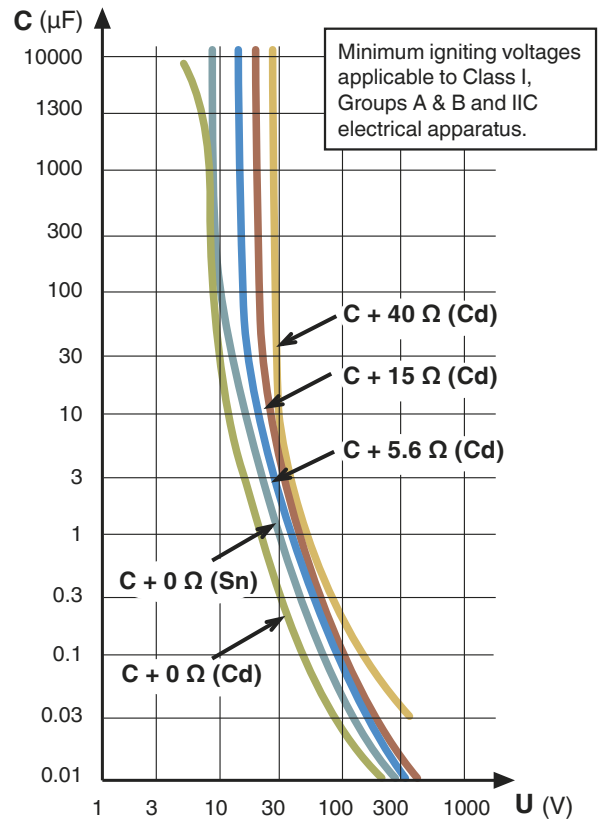

Figure 52 Minimum ignition curves for capacitive circuits group I

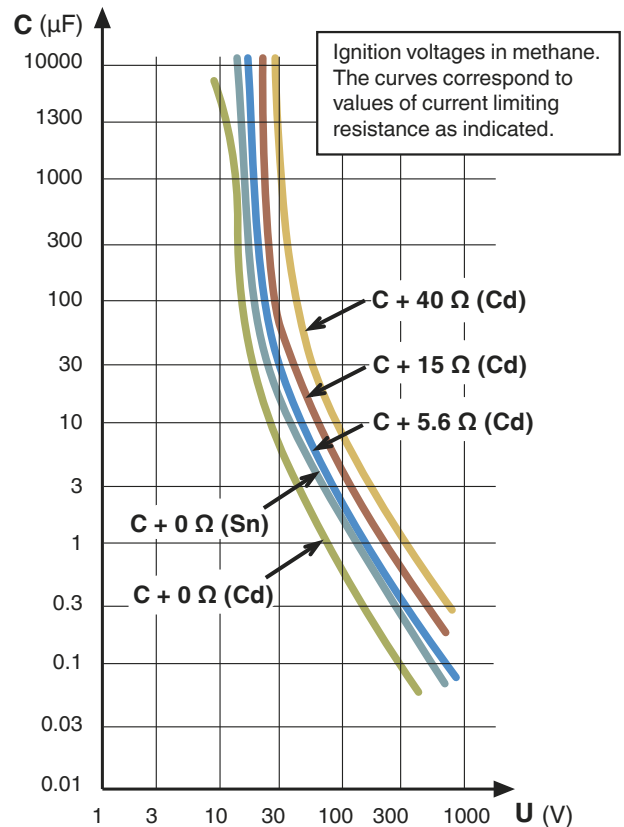

Figure 53 Minimum ignition curves for methane circuits

Edition 912907 (US) / 220718 (EU) 06/2011

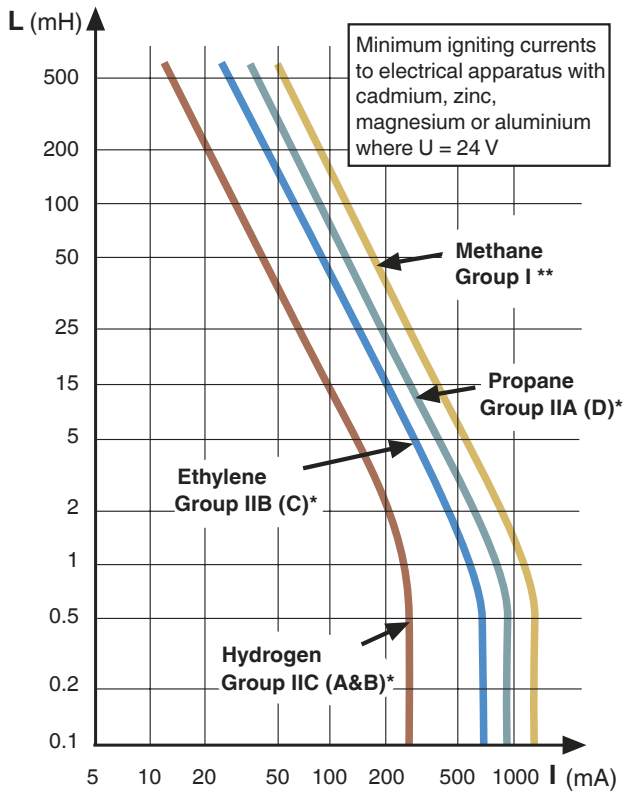

Figure 54 Minimum ignition curves for inductive circuits

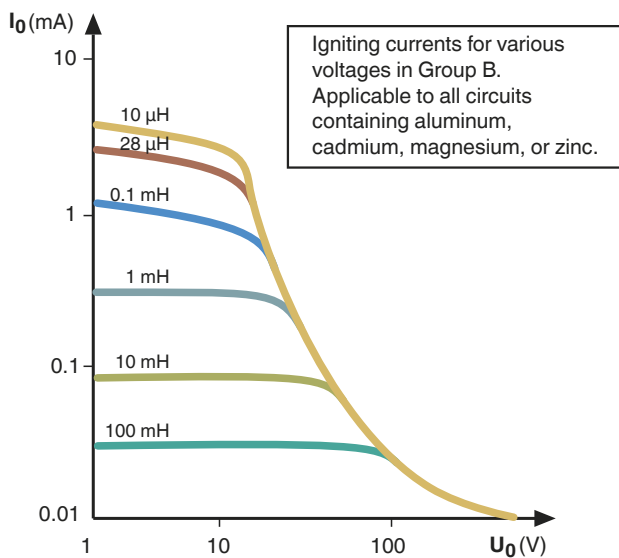

Figure 55 Certification curves showing relationship between inductance and minimum igniting current

Edition 912907 (US) / 220718 (EU) 06/2011

## Special Considerations Regarding Remote I/O Installations in Hazardous Areas

This chapter deals with some of the special requirements involved in hazardous area applications using Remote I/O.

### System Operator and Personnel

The operator of the system is responsible in terms of planning, mounting, commissioning, operating and maintenance.

Assembly, commissioning, operation, maintenance and dismantling of any devices may only be carried out by trained, qualified personnel who have read and understood the instructions manual.

### Zone 2, Zone 22 Installations

Zone 2 LB Remote I/O employ a variety of explosion protection methods as listed in the device type TAG.

**II 3(1) G Ex nA [ia] IIC T4 or  
II 3(1) G Ex nA [ia] IIB T4 or  
II 3(2) G Ex nA [ib] IIC T4**

Using suitable housings the category 3 equipment can be mounted in Zone 2 gas hazardous areas with intrinsically safe loops connected to sensors, transmitters, and actuators, valves or positioners mounted in Zone 2, Zone 1 or Zone 0 depending on the individual device markings.

**II (1) D [Ex iaD] IP66 T130°C or  
II (2) D [Ex ibD] IP66 T130°C**

Using suitable housings the equipment can also be mounted in Zone 22 dust hazardous areas with intrinsically safe loops connected to sensors, transmitters, and actuators, valves or positioners mounted in Zone 22, Zone 21 or Zone 20 depending on the individual device markings.

### Zone 1, Zone 21 Installations

Zone 1 FB Remote I/O employ a variety of explosion protection methods as listed in the device type TAG.

**II 2(1) G Ex d [ia] IIC T4 or  
II 2(1) G Ex d [ia] IIB T4 or  
II 2(2) G Ex d [ib] IIC T4**

Using suitable housings the category 2 equipment can be mounted in Zone 1 gas hazardous areas with intrinsically safe loops connected to sensors, transmitters, and actuators, valves or positioners mounted in Zone 1 or Zone 0 depending on the individual device markings.

**II (1) D [Ex iaD] IP66 T130°C or  
II (2) D [Ex ibD] IP66 T130°C**

Using suitable housings the equipment can also be mounted in Zone 21 dust hazardous areas with intrinsically safe loops connected to sensors, transmitters, and actuators, valves or positioners mounted in Zone 21 or Zone 20 depending on the individual device markings.

### Intended Use

Remote I/O modules (I/O modules, Com Units, power supplies) must only be used together with the respective backplanes.

Remote I/O modules act as an interface between signals from the hazardous area (Ex area) and the safe area (non-Ex area). The equipment is not suitable for isolating signals in high current applications unless this is noted separately in the corresponding data sheet.

The devices are only approved for appropriate and intended use. Ignoring these instructions will void any warranty and absolve the manufacturer from any liability. Protection of the operating personnel and the overall system is not ensured if the product is not being used according to its intended purpose.

### General Mounting

Prior to mounting, installation, and commissioning of the device you should make yourself familiar with the device and carefully read the instruction manual. The device must not be installed at locations where corrosive vapors may be present. The installation instructions in accordance with IEC/EN 60079-14 must be observed. The equipment is designed for use in degree of pollution 2 and overvoltage category II as per IEC/EN 60664-1. If devices have already been operated in general electrical systems, they may subsequently no longer be installed in electrical systems used in combination with hazardous areas.

Remote I/O modules installed in an enclosure with increased safety ignition protection class "e" may not contain only intrinsically-safe current circuits. Input / Output modules with non-intrinsically safe circuits may be operated near modules with intrinsically safe circuits. Observe the isolation requirements in IEC/EN 60079-14.

The terminals of non-intrinsically safe current circuits must be covered so that the intrinsically safe connections are accessible during operation.

The cover must reach IP degree of protection IP30 as specified in EN 60529. Select an installation position that ensures the climatic limits specified in the technical data are observed.



## Enclosures Mounted in Gas Hazardous Areas

If additional components are to be installed then a certificate must be obtained beforehand. The certificate must confirm that the permitted ambient temperatures of the Com Units, I/O modules and power supplies are maintained when the maximum anticipated external temperature is reached under all operating conditions. Enclosures supplied by Pepperl+Fuchs satisfy these conditions. Additional modules may be installed in free slots in Pepperl+Fuchs enclosures. Approval must be obtained for other enclosures.

The enclosure should only be opened for installation and maintenance purposes. Connection or disconnection of energized non-intrinsically-safe circuits is only permitted in the absence of a hazardous area.

When connected to the power supply, non-intrinsically safe connections must not be connected or disconnected unless a hot work permit is available. Intrinsically-safe current circuits may be connected or disconnected at any time. FB modules may be exchanged under live conditions during operation in Zone 1.

## Enclosures Mounted in Dust Hazardous Areas

Devices for use in dust hazardous areas should only be installed and operated in Zone 21 if installed in an enclosure with a minimum IP degree of protection of IP54 (non-conducting dust) or IP65 (conducting dust) approved for Zone 21 as per EN 60529. The enclosure must be certified together with the backplane, Com Units, power supplies and accessories.

If additional components are to be installed then a certificate must be obtained beforehand. The certificate must confirm that the permitted ambient temperatures of the Com Units, I/O modules and power supplies are maintained when the maximum anticipated external temperature is reached under all operating conditions. Enclosures supplied by Pepperl+Fuchs satisfy these conditions. Additional modules may be installed in free slots in Pepperl+Fuchs enclosures. Approval must be obtained for other enclosures.

The enclosure may only be opened if there is no risk caused by explosive, flammable dust. Connecting and disconnecting live components is only permitted during installation and maintenance if there is no risk posed by explosive, flammable dust. FB Remote I/O-System devices identified as associated apparatus (e. g. [iaD]) are suitable and approved for connection to intrinsically-safe sensors/actuators installed in the dust hazardous area. Apparatus must not be operated if dust deposits are thicker than 5 mm, as specified in EN 61241-1.

## Enclosures

If the device is installed in Zone 1 or Zone 21, the enclosure that accommodates the device must be suitable for the application. The enclosure must have the EC type examination certificate specified in RL 94/9/EC.

This also applies to enclosures supplied by Pepperl+Fuchs. Otherwise the relevant approval for the enclosure you wish to install must be obtained from a named authority. The same applies if additional components are installed in enclosures supplied by Pepperl+Fuchs, except when modules or components that are designed specifically for installation in Pepperl+Fuchs enclosures are replaced or added.

If additional housings are needed for installation in hazardous areas, the following points must be considered/evaluated:

- Degree of protection as per IEC/EN 60529
- Light resistance as per IEC/EN 60079-0
- Impact strength as per IEC/EN 60079-0
- Chemical resistance as per IEC/EN 60079-0
- Heat resistance as per IEC/EN 60079-0
- Electrostatics as per IEC/EN 60079-0  
Vacant openings must be closed off securely with sealing plugs to comply with the IP degree of protection. The seal kits for the relevant cable diameter should be used as well. Applying excessive force to cable glands may compromise the IP degree of protection. To ensure the IP degree of protection:
- all seals must be undamaged and have been correctly fitted
- all screws of the housing/housing cover must have been tightened with the appropriate torque
- only cable of the appropriate size must be used in the cable glands
- all cable glands must have been tightened with the appropriate torque
- all empty cable glands must have been sealed with sealing plugs  
If the seal on the enclosure cover or a seal on the cable or wire gland is damaged, they must be replaced with new seals provided by the manufacturer.

## Ignition Protection Classes and Protection Measures

For details of intrinsic safety, increased safety, flame proof equipment and other protection methods please refer to the relevant chapters in this document.

## Operation

The devices may not be repaired, changed or manipulated. If there is a defect, the product must always be replaced with an original part.

If the seal on the enclosure cover or a seal on the cable or wire gland is damaged, they must be replaced with new seals provided by the manufacturer.

The insulation must extend up to the terminal. The actual wire must not be damaged.

Fine-wire cables should be secured with a terminal lug. If two cables are connected to the same terminal, a double terminal lug should be used. Only certified cable or wire glands and sealing plugs should be used as a general rule. Coiled screw connections or other suitable cable glands with additional strain relief should be used for moving cables.

Observe the installation guidelines applicable for the cable or wire glands. When using cable or wire glands with a lower IP degree of protection than required for the device, the overall IP degree of protection for the device is reduced. Vacant openings must be closed off securely with suitable sealing plugs to comply with the minimum degree of protection.

When installing the cable or wire gland, ensure that suitable seal kits are used for the cable diameter. If custom seal kits are used, ensure that the insert is adapted correctly to the cable diameter.

All vacant cable or wire glands must be closed off with suitable sealing plugs for cable or wire glands.

## Maintenance

Observe IEC/EN 60079-17 and IEC/EN 61241-17 for maintenance and checking of associated electrical apparatus.

Regular maintenance is not necessary if the devices are operated properly and if the installation instructions and ambient conditions are observed.

Inspection, servicing and maintenance must be carried out by qualified and experienced personnel only. Individuals must thoroughly study all the different explosion protection methods during their training. The individuals must also know the relevant rules and regulations regarding zoning. The appropriate national standards must be observed. The maintenance intervals required are user-specific and depend on the operating conditions, these are therefore to be defined by the user. During maintenance, checks of components that determine the degree of protection take top priority (e.g. the condition and tightness of the enclosure, condition of the seals, cable or wire glands, and required potential equalization).

The devices may not be repaired, changed or manipulated. If there is a defect, the product must always be replaced with an original part.

## Inserting and Replacing Modules

In the safe area modules may be plugged in or unplugged during operation without switching off the power supply.

In hazardous areas electrostatic charges of plastic parts may cause a hazard. Electrostatic charges must be avoided. For example, never clean plastic parts with a dry cloth. Always use a damp cloth instead.

Remote I/O modules may be exchanged under live conditions during operation in Zone 2. However, connection or disconnection of energized non-intrinsically-safe circuits is only permitted in the absence of a hazardous atmosphere.

Remote I/O modules may be exchanged under live conditions during operation in Zone 1. Do make sure beforehand that the non-intrinsically safe circuits, which the modules are connected to via the front-side connectors, are de-energized. Commercially obtainable Ex-e-isolating switches or separating modules in flameproof enclosures (MFT) from Pepperl+Fuchs can be used for this purpose.

Never force the modules into the holders as this may damage the connector on the rear (guide groove). When inserting the FB modules, always ensure that the rear catch latches into the plastic holder of the backplane. Always use the extractor tool supplied with the FB enclosure when removing modules.

Bent rear connectors result in a loss of explosion protection. Never insert modules with bent or damaged connectors into the backplane! Never attempt to repair I/O modules with bent connecting pins yourself. Return faulty modules to the manufacturer for repair.

Technology

Basic Principles

Applications

Ex Protection  
Intrinsic Safety

Functional  
Safety

Edition 912907 (US) / 220718 (EU) 05/2011

# Functional Safety (SIL)

## Risk

### Risks in General

Risks are part of our daily lives and even the workplace is not free of danger. This makes it all the more important to detect risks to life and limb and wherever possible to exclude the dangers that can arise during production processes for example.

### Risks are Subjective

A risk is the probability that a dangerous event will occur multiplied by the resulting consequences. These include consequences in the form of damage to health, as well as the physical damage caused by the incident and the associated costs.

It is impossible to provide absolute protection from risks. There will always be a residual risk that is evaluated on the basis of several factors:

- Country and region
- Social environment
- Legal position
- Incidental costs

The assessment of the residual risk is largely a question of subjective judgment.

### Limiting Risks

Risks cannot be totally avoided, however it is possible to limit them efficiently. Under the controlled conditions of an industrial process in particular, a wide range of mechanical and electronic measures is available to reduce the probability of a hazardous incident, thus minimizing the residual risk to an acceptable extent.

To prevent negative impact on personnel, the environment and technical equipment, the first step is to determine the possible risks. Next, suitable protective measures need to be implemented. These measures can be very varied in nature.

- Structural measures
- Measures to spread risk
- Evacuation plans
- Safety-related controllers and protection devices

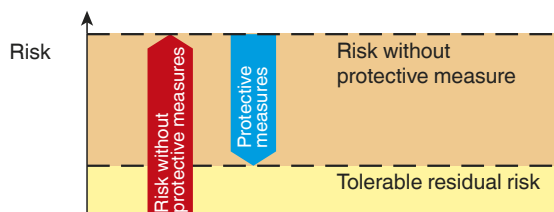

Figure 1 Presenting the risk reduction

## Protective Measures on Different Levels

Measures to reduce the residual risk with a production system can be divided into different approaches, also referred to as production levels. These are hierarchical in structure and must each be considered in isolation.

The underlying principle is very simple: if one protective level fails, the next highest level is automatically activated to prevent, or at least limit, possible damage. The following level-based model shows the different types of protection measure and how they relate to each other:

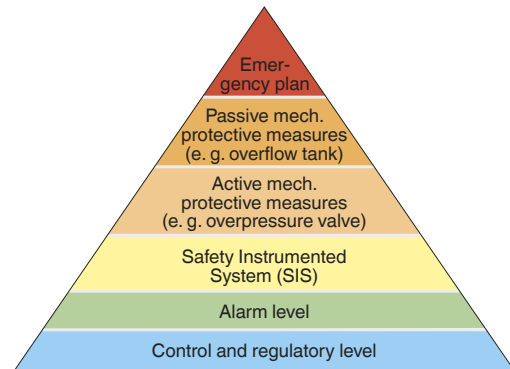

Figure 2 Protection levels on the system

The individual protection levels must operate absolutely independently of each other. Thus, for example, the controller and regulator technology on the lowest level cannot also be used for safety applications on a higher level. The reduction of the existing risk is the result of all measures on the various protection levels. The objective pursued here is to avoid possible damage insofar as possible and to reduce the unavoidable residual risk to an acceptable degree.

## Risk Analysis

There are clear criteria for determining the risk associated with a processing system set down in IEC/EN 61511. The risk determined according to these criteria dictates the measures to be taken to reduce the risk. If this risk is limited with the help of installed automation technology, then the components used for this purpose must meet the criteria contained in IEC/EN 61508. Both standards divide the measures to reduce risks into four safety stages, which range from SIL1 for a low-level initial risk to SIL4 for a very high-level initial risk.

The following overview shows the link between the risk parameters and the Safety Integrity Level (SIL) of the Safety Instrumented Functions (SIF).

**Consequence (severity)**  
**C<sub>1</sub>** minor injury or damage  
**C<sub>2</sub>** serious injury or one death, temporary serious damage  
**C<sub>3</sub>** several deaths, long-term damage  
**C<sub>4</sub>** many dead, catastrophic effects

**Frequency/exposure time**  
**F<sub>1</sub>** rare to quite often  
**F<sub>2</sub>** frequent to continuous

**Possibility of avoidance**  
**P<sub>1</sub>** avoidance possible  
**P<sub>2</sub>** unavoidable, scarcely possible

**Probability of occurrence**  
**W<sub>1</sub>** very low, rarely  
**W<sub>2</sub>** low  
**W<sub>3</sub>** high, frequent

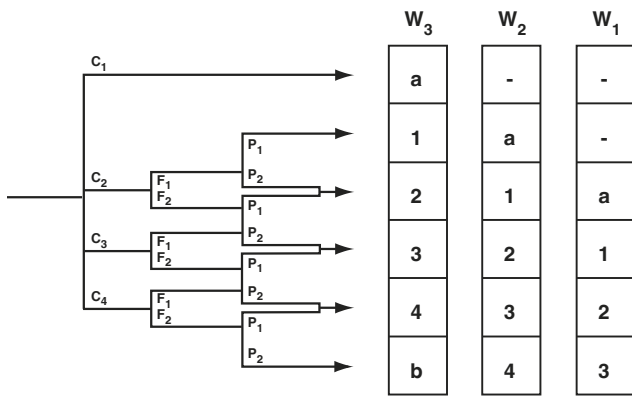

1, 2, 3, 4 = Safety integrity level  
 - = Tolerable risk, no safety requirements  
 a = No special safety requirements  
 b = A single E/E/PE is not sufficient

Figure 3 Risk graph

### Safety Integrity Level (SIL)

The various parts of a processing system are associated with different risks. However, as a risk increases, the need for the availability of the Safety Instrumented System (SIS) also increases.

The higher the safety integrity level the greater the risk reduction. This means that the SIL is a measure of the probability that the safety system can meet the required safety functions for a particular period. There are different ways to determine the required SIL or a risk reduction measure (protective function). Standards IEC 61508 and IEC 61511 (sector standard for the process industry derived from IEC 61508) list different methods to determine the SIL.

### Low Demand and High Demand Mode

The process industry and production industry have different requirements in relation to the safety system because the applications in these industrial areas are very different. The key distinguishing feature is the demand rate in relation to the safety system. Here a distinction is made between high demand and low demand mode.

#### Low Demand Mode

Low demand is understood as a mode with a low demand rate for the safety system. This classification requires that the safety system should not be demanded more than once per year.

| SIL  | PFD                        | Max. accepted failure of the SIS               |
|------|----------------------------|--|
| SIL1 | $> 10^{-2}$ to $< 10^{-1}$ | Max. one dangerous failure per 10 requests     |
| SIL2 | $> 10^{-3}$ to $< 10^{-2}$ | Max. one dangerous failure per 100 requests    |
| SIL3 | $> 10^{-4}$ to $< 10^{-3}$ | Max. one dangerous failure per 1,000 requests  |
| SIL4 | $> 10^{-5}$ to $< 10^{-4}$ | Max. one dangerous failure per 10,000 requests |

Table 1 Failure limit values for a safety function operated in the Low Demand Mode.

#### High Demand Mode

This is a mode with a high demand rate or with continuous demand on the safety system. In practice, this means that the security system operates continuously or is demanded more than once per year.

| SIL  | PFH                        | Max. accepted failure of the SIS                 |
|------|----------------------------|--|
| SIL1 | $> 10^{-6}$ to $< 10^{-5}$ | Max. one dangerous failure per 100,000 hours     |
| SIL2 | $> 10^{-7}$ to $< 10^{-6}$ | Max. one dangerous failure per 1,000,000 hours   |
| SIL3 | $> 10^{-8}$ to $< 10^{-7}$ | Max. one dangerous failure per 10,000,000 hours  |
| SIL4 | $> 10^{-9}$ to $< 10^{-8}$ | Max. one dangerous failure per 100,000,000 hours |

Table 2 Failure limit values for a safety function operated in the mode with high or continuous demand rate (High Demand)

High Demand Mode (or continuous mode) is mostly used in production technology. In this case it is often necessary to monitor work processes continuously in order to ensure the safety of personnel and of the environment.

Low Demand Mode (on demand mode) is used in the process industry. Emergency stop systems are a typical example of this, only becoming active when the process runs out of control. This normally occurs less than once per year. This is why high demand mode is meaningless for process instrumentation in most cases.

The following descriptions thus relate solely to low demand systems.

## PFD Value

Details of the SIL or the individual components are not sufficient for planning safety systems. While, in the past, the safety chain was able to reach the requirement grade (AK acc. to DIN 19250) of the weakest component, today the SIL calculations must be carried out on the basis of the probability of failure. PFD (= **P**robability of **F**ailure on **D**emand) is of central significance here. The PFD is the average probability that a safety system will not be available just at the moment when this safety function is required.

Components' PFDs are determined in a complex analytical process, known as the FMEA (**F**ailure on **M**ode and **E**ffect **A**nalysis) in which analysis takes place down to an individual component level to ascertain what happens when a particular failure occurs and to establish whether this can be detected.

In the low demand systems considered here, the dangerous, undetected failure  $\lambda_{du}$  plays a significant role. Such failures are detected during the course of a proof test and eliminated. Inversely, a change to the interval for testing changes the probability of failure when a demand is made. Every driver is familiar with this situation when he takes his car for its two-year road-worthiness test. Naturally, performing this test at annual or semi-annual intervals would increase the safety of the car, but this would also entail higher costs. Sometimes, however, reducing the test interval  $T_{proof}$  is the only way to achieve a required SIL. The PFD value is used for allocation to a SIL, among other things.

## SFF and HFT

Two other parameters are used to define the safety integrity of the device: the proportion of non-dangerous failures (SFF, **S**afe **F**ailure **F**raction) and the hardware failure tolerance (HFT, **H**ardware **F**ailure **T**olerance).

The SFF value expresses the proportion of non-dangerous failures in relation to the totality of all possible failures. A non-dangerous failure is defined as a failure that is either detected and/or that transfers the system to a safe state.

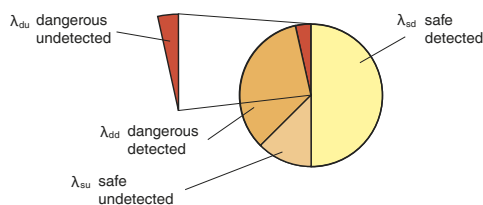

Figure 4 Proportion of non-dangerous failures (SFF)

Thus, for example, an SFF of 90 % indicates that only 10 % of the possible failures in a safety system would result in a dangerous state if they went undetected.

HFT describes the tolerance of a device or system in relation to hardware failures. Systems with no redundancy, in other words in which the safety function is no longer guaranteed if a single failure occurs, have a HFT = 0. With single redundancy the HFT = 1 and with double redundancy the HFT = 2.

The combination of the SFF and HFT parameters yields the SIL of a device. However, a distinction is made between simple devices (type A) in which all failures are known and describable and more complex devices (type B), in which not all failures are known and describable, as is the case with microprocessor systems or software solutions, for example.

Of the two different SILs yielded from the PFD and the combination of SFF and HFT, the lower value is assumed to be the SIL of the device or system.

### Simple Devices

| SFF (Safe Failure Fraction) | HFT (Hardware Failure Tolerance) |      |      |
|-----------------------------|----------------------------------|------|------|
|                             | 0                                | 1    | 2    |
| < 60 %                      | SIL1                             | SIL2 | SIL3 |
| 60 % ... 90 %               | SIL2                             | SIL3 | SIL4 |
| 90 % ... 99 %               | SIL3                             | SIL4 | SIL4 |
| > 99 %                      | SIL3                             | SIL4 | SIL4 |

Table 3 The link between SFF and HFT in simple devices (type A)

### Complex Devices

| SFF (Safe Failure Fraction) | HFT (Hardware Failure Tolerance) |      |      |
|-----------------------------|----------------------------------|------|------|
|                             | 0                                | 1    | 2    |
| < 60 %                      | -                                | SIL1 | SIL2 |
| 60 % ... 90 %               | SIL1                             | SIL2 | SIL3 |
| 90 % ... 99 %               | SIL2                             | SIL3 | SIL4 |
| > 99 %                      | SIL3                             | SIL4 | SIL4 |

Table 4 The link between SFF and HFT in more complex devices (type B)

## Failure Types

In the case of a safety instrumented system (SIS), a distinction is made between systematic and random failures. In order to meet the required SIL criteria, both failure types must be analyzed separately.

### Random Failures

Random failures are all failures that occur at random during operation and that are triggered by hardware defects. Such failures do not already exist at the time of delivery and may be the result of a short circuit, interruption, component movement, etc. Their probability and the associated failure rate can be calculated. The various hardware components of a SIS are analyzed separately and the PFD is calculated from the individual  $\lambda$  values; the PFD is in turn used to determine the SIL value.

### Systematic Failures

Unlike random failures, systematic failures already exist upon delivery and are characteristic of every individual device or system. They typically involve development errors, installation errors or errors during planning, for example software errors, incorrect dimensioning, incorrect configuration of the measuring instrument, etc.

The majority of systematic failures can be traced back to errors in the device software. The fundamental issue with systematic software errors is that programming errors can also lead to errors in the process. Systematic failures must, therefore be avoided when designing the SIS by taking particular steps. This is the purpose of a quality management system that constitutes a key component of EN 61508/61511. Thus, device manufacturers must provide details of SIL classification in relation to systematic failures. This information is generally contained in the declarations of conformity for the individual devices.

Depending on the SIL, the information is provided through certification by external, impartial organizations (TÜV, Exida). If the requirements for a particular SIL (e. g., SIL3) are to be met in relation to the systematic failure, the entire safety instrumented system (SIS) must be considered accordingly.

### Common Cause Failures

So-called common cause failures are special systematic failures. This category includes all failures that apply simultaneously to all the components of a safety instrumented system (SIS) and are mostly caused by external influences, such as electromagnetic malfunctions (EMC), temperature, or mechanical stress. In order to cater for such failures, the standard places specific quality requirements on the development process, the change process and the hardware and software architecture of the device.

Depending on the measures implemented, you will get a larger or smaller percentage of common cause failures. This is specified as a beta factor.

### Diverse Redundancy in the Case of Systematic Failures

It is also possible to use SIL2 components for SIL3 protective functions if measures have been taken that do not leave a systematic failure at SIL2 level. For example, if SIL2 pressure sensors are to be used in a SIL3 level safety instrumented system (SIS), it must be ensured that different device software is used. This can be achieved by using two different devices, for example. Diverse redundancy certainly exists if different technologies are used instead of different devices, for example with a pressure sensor and temperature sensor.

### Error Distribution in the Safety Instrumented System (SIS)

A safety instrumented system (SIS) consists of several linked components all of which are part of the safety instrumented function (SIF). The PFD value derived from the SIL evaluation is distributed among all these relevant components, depending on the failure risk.

The sensors and actuators generally feature the highest risk of failure because they are installed in the field and are subject to chemical and physical stresses from external influences, such as process medium, pressure and temperature. Thus, 25 % of the entire PFD is set aside for sensors and 40 % for actuators. The fail-safe controller has a 15 % PFD share. The PFD value for the interface modules is assigned to the sensor or actuator circuit with 10 % each. However, the numeric values assumed here can vary depending on the application.

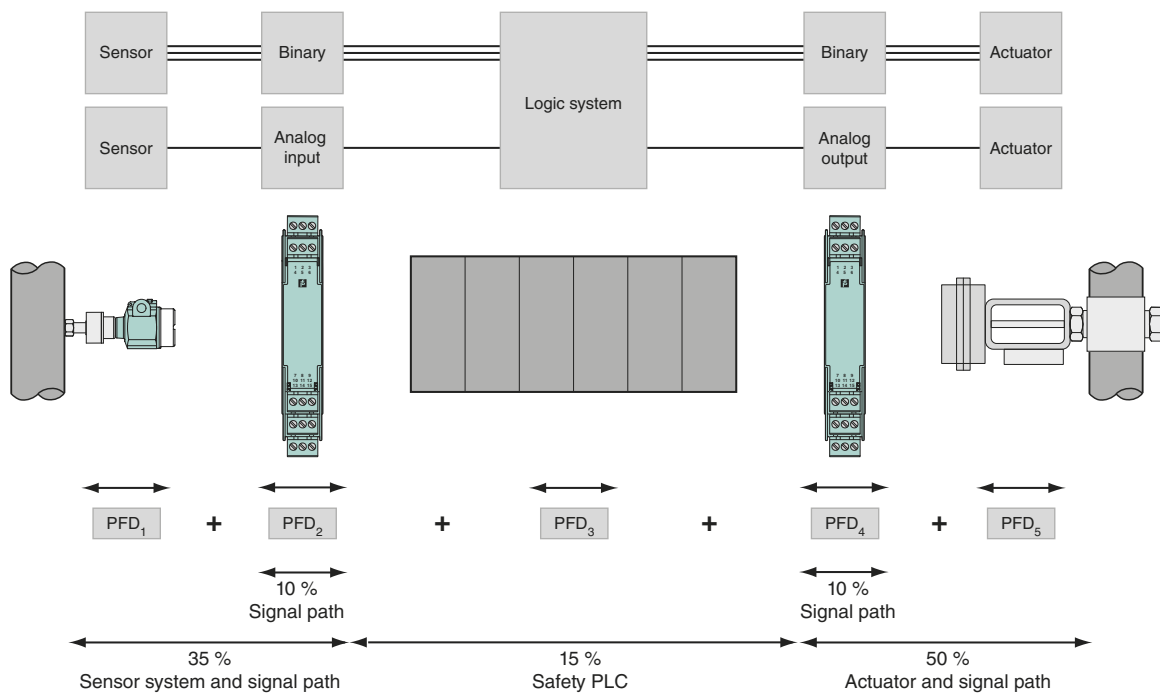

Figure 5 Error distribution in the safety instrumented system (SIS)

Edition 912907 (US) / 220718 (EU) 05/2011

## Measures to Increase the SIL of a Safety System

### Reducing Test Intervals

In low demand safety systems, the test intervals  $T_{proof}$  are incorporated in the result in an almost linear pattern. Thus, reducing the testing intervals can increase the SIL. However, the increased frequency of testing also pushes up costs.

### Configuring Redundancies

The redundancy used here can play a decisive role in improving the SIL. For example, we refer to 1oo2 (1 out of 2) or 2oo3 (2 out of 3) redundancies. If, for example, temperature is measured, a second, redundant measuring transmitter of the same type will reduce the likelihood of failure. However, this leads to the possibility that the two measuring transmitters will fail due to a common cause failure when they are under a shared load. This might be a systematic error in the measuring transmitter software that affects both devices at the same moment, for example when a certain measurement result occurs.

Redundant layout, 2-channel  
with two identical devices

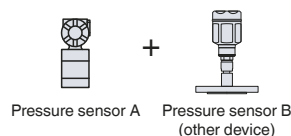

Figure 6 Configuring 2-channel redundancy

The most effective option is thus so-called diverse redundancies, which operate with different measuring devices and methods.

In such diverse redundancies, measuring transmitters from different manufacturers are used, possibly even with different measuring techniques. This reduces the probability of common cause failures. This also means that the beta factor is reduced.

Configure diverse redundancy  
Two different devices  
(this is to ensure that a systematic  
fault cannot occur simultaneously)



Two different technologies

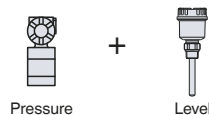

Figure 7 Configuring diverse redundancy

## Questions about SIL

### What is the purpose of SIL devices?

For manufacturers and users, the standard represents a common basis for monitoring the effectiveness of their development processes for example. For users, the decision in favor of devices with SIL certification from the manufacturer has the advantage that the relevant SIL will very probably be attained for their safety instrumented function (SIF). This makes it much easier for system operators to provide proof of risk reduction, as required by law in order to obtain permission to operate their systems.

It is not absolutely essential that products that already have SIL classification from the manufacturer should be used. However, this makes certification much easier because the risk of failure is already known for these products.

### Is there any advantage in having the highest possible SIL?

System operators are required to provide proof of the safety of their systems. The determination of the risk posed by a particular production system results in the demand for a particular SIL from a protective device. For cost reasons, system operators aim for the lowest possible SIL. However this not only yields a cost benefit, but also a much greater choice of devices. A high SIL is only necessary if it is unavoidable or if this would produce a cost benefit elsewhere, so that additional costs can be avoided (e. g., the avoidance of complex additional construction measures).

### Which devices are suitable for which SIL?

To achieve a particular SIL (SIL1 ... SIL4), the entire safety instrumented system (SIS) must meet the requirements in relation to systematic failures (in particular in the area of software) and random failures (in the area of the hardware). This means that the result of the calculation of the entire safety instrumented system must meet the required SIL. In practice, this mainly depends on the conceptual design of the system or of a particular process circuit. Thus, it may be possible to use SIL2 devices in a safety instrumented system requiring SIL3 because it is often less expensive to use two SIL2 devices than a single SIL3 device.



### Is redundancy still absolutely necessary with devices with a higher SIL classification?

Although it is theoretically possible to drop redundancy in this case, this is usually rejected by NAMUR\*. This also makes sense in relation to field devices in particular because these usually come into direct contact with process media, resulting in risks that are difficult to calculate. In addition, just one device class is required that meets the requirements of SIL2.

These SIL2 devices are used both for protective devices and operational devices. SIL3 circuits should not be instrumented with a 1-channel with SIL3 devices, but rather with two SIL2 devices using 1oo2 redundancy. This permits uniform inventory management and limits the training required by service technicians to just a small number of devices.

### SIL in Process Automation

#### Isolated Barriers and Zener Barriers

A variety of different solutions is possible in conjunction with intrinsically safe components and systems. The classic answer is direct point-to-point connections with Zener Barriers or isolated barriers. Zener Barriers act as simple, passive networks and are the simplest solution. However, circuits with Zener Barriers entail functional risks due to the longitudinal resistance and the ground connection of the equipotential bonding. That's why galvanic isolated barriers have been the preferred solution for some years now. The parameters required for planning purposes, such as PFD or testing intervals  $T_{proof}$  are documented in the relevant test reports or safety manuals.

However, the use of isolated barriers can cause a problem when configuring the safety chain. Because both the sensor circuit and actuator circuit contain another element, the PFD or the safety chain are incremented by these values. It is, therefore, advisable that an isolated barrier that can be used for safety circuits should take up a maximum of 10 % of the entire PFD value available for the required safety integrity level. Thus, for example, while a PFD value of  $5 \times 10^{-3}$  is sufficient for a SIL2, the corresponding isolating interface should "use" a maximum of  $5 \times 10^{-4}$ . If this is not possible or if there is no corresponding isolating interface available, the only alternative is redundancy as described above.

\* NAMUR is an association that represents users of automation technology in the process industry.

### SIL and HART Communication

Special HART management systems are available for evaluating the HART data; these enable the HART signals to be gathered, loaded and evaluated by means of a HART Multiplexer. Because the HART Multiplexer intervenes in the safety circuit and could falsify the relevant analog process signals, it must naturally also have a SIL evaluation. The SIL evaluation of the HART Multiplexers does not include the use of the HART information for checking the safety chain, but rather the certification that it has no safety-related influence on the analog signal.

### Summary

The aim of every safety concept is to reduce the risk appropriately. The use of standard structures means that less planning and certification effort is required when implementing process control protection equipment. On the other hand, there is enough freedom to enable the optimum configuration of protection equipment in terms of function and cost using the benefits of the quantitative approach of IEC 61511. This concept has proven very effective in large chemicals businesses in recent years.

IEC 61511 has proven itself an excellent, practical tool. One of the main advantages for globally active businesses in particular lies in its worldwide applicability and the associated uniform evaluation benchmarks for process control protection equipment.

SIL levels 1 and 4 are not used in large chemical businesses. SIL4 is defined in IEC 61511-1 as the highest possible value that can be achieved using process control resources.

However, it should be pointed out at the same time that, with such a high value, the relevant process should be checked and/or mechanical protection equipment should be used before installing process control protection equipment.

For SIL3 circuits, IEC 61511 requires a hardware tolerance (HFT) of 1. This should prevent 1-channel protective circuits from being planned and implemented on the basis of dubious  $\lambda_{du}$  values, particularly at higher risks. This requirement largely corresponds to the previous national procedure for configuring low risk protective functions (< SIL3) with 1-channel and higher risk protection functions (SIL3) with multiple channels.

Because of the small proportion, representing less than 1 % of all process control functions, the demand for field devices for use in SIL3 protection circuits is low. Consequently, it could prove worthwhile developing special devices with SIL3 according to IEC 61508 for use in protection equipment, particularly for special applications. However, because of a lack of experience with non-safety applications, the additional storage capacity needed for spare devices and, not least, because of the necessarily high prices, such special devices are not necessarily the optimum solution.

Technology

Basic Principles

Applications

Ex Protection  
Intrinsic Safety

Functional  
Safety



## Bus-Independent Functional Safety

Safety systems play an important role in industry. In the past a second shutdown system has often been necessary in conjunction with Remote I/O. Modern Remote I/O have SIL2 classifications for all analogue and digital output modules and therefore often render the installation of a separate shutdown device (ESD – **E**mergency **S**hutdown) superfluous. This is achieved by bypassing the non-safety relevant control system, the bus network and the Remote I/O gateway. The shutdown works directly on the output modules. It is purely a hardware solution, which does not have to take account of any software. The figure shows an example of the function of the shutdown circuit for a valve driver.

The output is switched off when the emergency switch is actuated. At the same time the status information of the inputs for the control system can still be read. So the switching status of the valves can be transmitted, as can the fact that the emergency shutdown has been activated. In this case opto couplers are used for the individual shutdown of the output line of the modules instead of interrupting the auxiliary power for the module. This way no unnecessary fault messages are sent to the control system. A host of alarms might otherwise have led to the whole station being disabled due to the overflow of the alarm memory.

Special modules with a separate shutdown input have been developed for this purpose. The respective order numbers can be found in the technical documentation. These modules are marked on the front with the associated letter code. The relevant SIL2 parameters are available at request.

The block diagram shows how the control circuit to the solenoid valve can be interrupted via a bus-independent optocoupler input.

The control input for the shutdown of the output is switched via an external, volt-free contact with the aid of the internal 12 V supply. When the contact is closed, the outputs are controlled via the bus. When the contact is open, there is no current to the outputs.

The potential-free control contact avoids stray potentials. If installed in Zone 1, a suitable Ex e contact must be used for this purpose.

## Combination of Modules with and without Shutdown

Modules with a shutdown input and modules without a shutdown input can be combined in the same field bus station. Modules without a shutdown input are always controlled by the bus, independently of the position of the external shutdown contact.

Modules with a shutdown input are only controlled by the bus when the shutdown contact is closed. The shutdown contact may be operated via a local emergency switch or the main safety system.

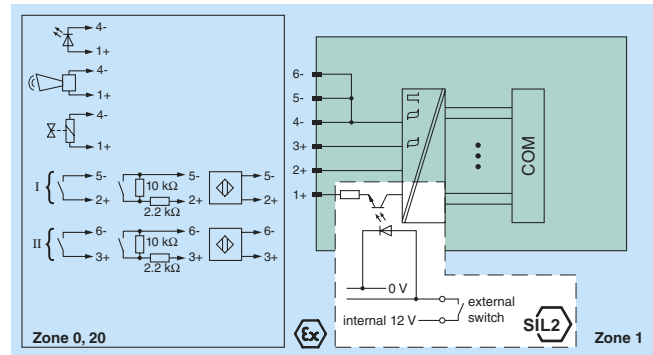

Figure 9 Example: Solenoid driver with valve position feedback

Technology

Basic Principles

Applications

Ex Protection  
Intrinsic Safety

Functional  
Safety



Edition 912907 (US) / 220718 (EU) 05/2011

Subject to modifications without notice

Pepperl+Fuchs Group  
www.pepperl-fuchs.com

USA: +1 330 486 0002  
pa-info@us.pepperl-fuchs.com

Germany: +49 621 776 2222  
pa-info@de.pepperl-fuchs.com

Copyright Pepperl+Fuchs  
Singapore: +65 6779 9091  
pa-info@sg.pepperl-fuchs.com



# Remote I/O Isolated Barriers



Edition 912907 (US) / 220718 (EU) 06/2011



Isolated barriers for intrinsic safety applications are used in factory and process control for the galvanic isolation of control and instrumentation signals, such as NAMUR sensors, 4 mA ... 20 mA and 0 V ... 10 V signals. These devices are also used to convert specialized measurement signals into standard control signals. Isolated barriers have intrinsically safe control circuits in order to operate and communicate with field devices in hazardous areas. In all cases, the respective statutory regulations and directives governing the application or intended use shall be observed.

## Operating Principle

Isolated barriers are a combination of an intrinsic safety Zener Barrier and a galvanic isolation network. The energy limitation delivered to the field (voltage and current) is achieved through the Zener Barrier. In simple terms, a Zener Barrier contains a zener diode for voltage limitation and resistor for current limitation. These components are protected with a fuse.

The galvanic isolation contained within the isolated barriers prevents noise, potential effects and transients from affecting the measurement signals. Although necessary for stand-alone Zener Barriers, an isolated barrier does not require a connection to earth (ground).

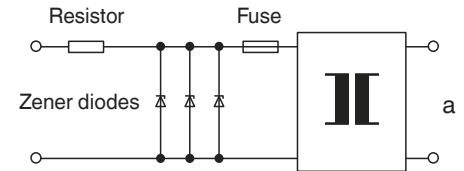

## LB-System

102



- 2 to 8 channels digital
- 1 to 4 channels analog
- Zone 2 or Div. 2 mounting possible
- Plug-in modules for analog and digital inputs and outputs
- Screw-in and plug-in cable connections directly on the module
- Safe galvanic isolation
- Low power consumption
- ATEX certification for Ex ia/ib
- Suitable for all well-known PLC, DCS, and SCADA systems
- International approvals

## FB-System

192



- 2 to 8 channels digital
- 1 to 4 channels analog
- Zone 1 mounting possible
- Plug-in modules for analog or digital inputs and outputs
- Screw-in and plug-in cable connections directly on the module
- Safe galvanic isolation
- Low power consumption
- Similar electronic and identical Ex-i features as LB Remote I/O
- ATEX certification for Ex ia/ib
- Suitable for all well-known PLC, DCS, and SCADA systems
- International approvals

- LB-System
- Digital Inputs
- Digital Outputs
- Analog Inputs
- Analog Outputs
- Bus Couplers
- Power Supplies
- Accessories

# LB-System



Edition 912907 (US) / 220718 (EU) 05/2011

|                                  |            |                        |
|----------------------------------|------------|------------------------|
| <b>System Description</b> .....  | <b>104</b> |                        |
| <b>Digital Inputs</b>            |            |                        |
| <b>Selection Tables</b> .....    | <b>111</b> | <b>LB-System</b>       |
| <b>Product Data Sheets</b> ..... | <b>112</b> |                        |
| <b>Entity Parameters</b> .....   | <b>121</b> |                        |
| <b>Digital Outputs</b>           |            | <b>Digital Inputs</b>  |
| <b>Selection Tables</b> .....    | <b>123</b> |                        |
| <b>Product Data Sheets</b> ..... | <b>124</b> |                        |
| <b>Entity Parameters</b> .....   | <b>136</b> | <b>Digital Outputs</b> |
| <b>Analog Inputs</b>             |            |                        |
| <b>Selection Tables</b> .....    | <b>137</b> |                        |
| <b>Product Data Sheets</b> ..... | <b>138</b> | <b>Analog Inputs</b>   |
| <b>Entity Parameters</b> .....   | <b>149</b> |                        |
| <b>Analog Outputs</b>            |            | <b>Analog Outputs</b>  |
| <b>Selection Tables</b> .....    | <b>151</b> |                        |
| <b>Product Data Sheets</b> ..... | <b>152</b> |                        |
| <b>Entity Parameters</b> .....   | <b>158</b> | <b>Analog Inputs</b>   |
| <b>Bus Couplers</b>              |            |                        |
| <b>Selection Tables</b> .....    | <b>159</b> | <b>Bus Couplers</b>    |
| <b>Product Data Sheets</b> ..... | <b>160</b> |                        |
| <b>Power Supplies</b>            |            | <b>Power Supplies</b>  |
| <b>Selection Tables</b> .....    | <b>165</b> |                        |
| <b>Product Data Sheets</b> ..... | <b>166</b> | <b>Accessories</b>     |
| <b>Accessories</b>               |            |                        |
| <b>Selection Tables</b> .....    | <b>167</b> |                        |
| <b>Product Data Sheets</b> ..... | <b>170</b> |                        |





## Introduction

LB Remote I/O stations are important signal conditioning devices to interface signals from the field with controllers or process control systems. The plug-in modules are mounted on pre-fabricated, plastic backplanes for use in potentially explosive atmospheres in Zone 2 or Zone 22 or Div. 2.

Hot swapping of the various intrinsically safe I/O modules is possible. In addition to the easy plug-in mounting method, the other advantages of the LB Remote I/O modules are the galvanic isolation and the amplification properties. What is more, the conventional I/O boards for the PLC or DCS are no longer required. Wiring is reduced to that of a standard bus connection. The galvanic isolation provides a safe and reliable interface between the process and the bus. The amplification properties and the digital transmission ensure a high degree of measurement accuracy that, in addition, is not influenced by variations in the auxiliary power supply.

LEDs indicate the status of the respective device. A green LED indicates the operating status, while a red LED indicates a fault, e. g. an open line or short circuit. This information can be accessed from the DCS and PLC via the bus.

LB-System

Digital Inputs

Digital Outputs

Analog Inputs

Analog Outputs

Bus Couplers

Power Supplies

Accessories

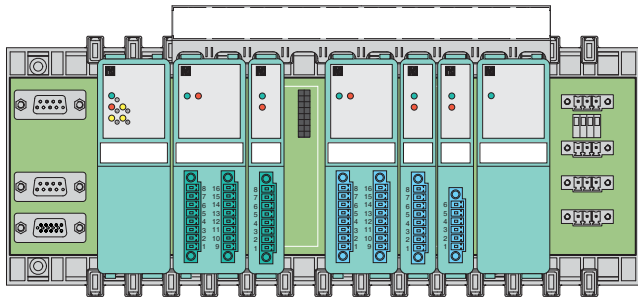

Figure 1 Smallest LB Remote I/O station

## Components

### Modules

The compact 16 mm design of the modules allows a high packing density without the heat problems associated with conventional devices. The snap-on fixing method utilizes the very latest moulded plastic technologies, thus allowing the LB Remote I/O modules to be fixed firmly in position without screws. Wires from the field are connected via Mini-Combicon plug-in connectors from Phoenix. These can be coded and are located on the front of the modules.

The system is designed in such a way that each module can be plugged into any desired slot on the backplane, whereby the IS connections are adapted to the wiring and not vice-versa.

As many as 22 I/O modules can be fitted on the base backplane. Depending upon the application, high-availability single-channel modules or compact modules with up to eight channels can be used.

A wide range of signal conditioning components is available for all kinds of applications, including HART communication.

### Single Width Modules

- 16 mm housing
- Mostly 1-channel devices

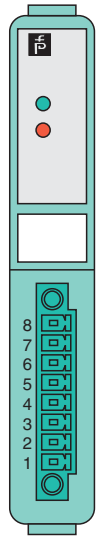

Figure 2 Single width modules

### Dual Width Modules

- 32 mm housing
- Multi channel devices

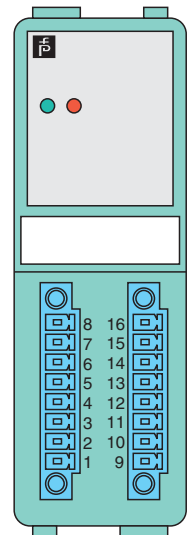

Figure 3 Dual width modules

### Power Supplies

Two power supply units supply up to 24 signal conditioning modules. Together they ensure adherence to the EMC requirements for the overall system according to NAMUR and EMC legislation.

### Communication Units (Com Units)

The Com Unit interfaces the I/O modules with the control system. The unit can serve up to 46 I/O modules and is available for various standard busses. The Com Unit is installed at the left end of the backplane.

Com Units are often referred to as gateways or bus couplers all meaning the same function.

### Bus Stations (Backplanes)

Bus stations can be connected to process control systems (DCS) and programmable logic controllers (PLC) of all renowned manufacturers via the available standard busses.

All the module sockets have equal priorities. So devices of any function can be mounted next to any other devices. Marshalling can be arranged via software.

Intrinsically safe I/O modules can be mounted next to non-intrinsically safe modules as long as the spacing between exposed parts of the front connectors exceeds the required 50 mm. This can be achieved by using covered front connectors (see accessories).

Modules as well as power supplies may be hot swapped. This also applies to Zone 2 mounted equipment under normal conditions (see operating instructions).

Redundant backplanes have two slots for Com Units at the left hand side of the backplane. The leftmost Com Unit is connected to the topmost bus connector. The right hand redundant Com Unit is linked to the lower bus connector.

The remaining 9-pin bus connector is reserved for the service bus. The bottom most connector accepts the connector cable to link the base backplane to the extension backplane.

The backplane circuit board is screwed to the plastic structure. At the same time these screws connect it to the metal plate. This ensures the best possible EMC immunity.

### Base Backplanes

Backplanes accept LB Remote I/O modules which act as interfaces between signals in the hazardous area and the safe area.

The base backplanes LB 9022 will take up to 22 single width modules or 11 dual width devices or any combination of the same. They are ready to accommodate redundant Com Units.

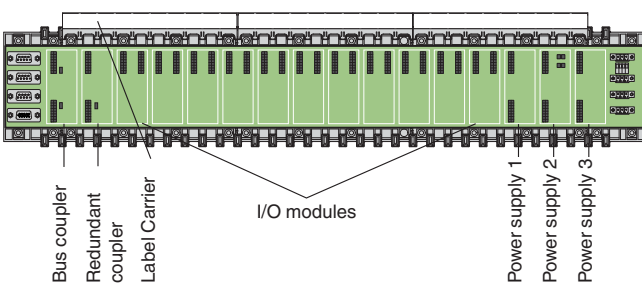

Figure 4 Example base backplane

### Extension Backplanes

Due to the modular design concept, a base backplane can be combined with extension backplane to form a station of the required size. The power feed is on the right side of each backplane, and the communication connections are on the left of the base backplane.

The extension backplane LB 9024 can again take up to 24 single width modules or 12 dual width devices or any combination of the same.

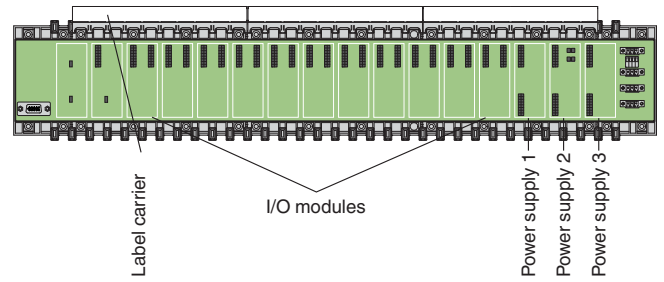

Figure 5 Example extension backplane

### Possible Backplane Combinations (Recommended for new Installations)

| Combination   | Max. number of slots           | Redundancy |     |
|---|--------------------------------|------------|-----|
| Base backplane LB 9022 A                                    | Extension backplane LB 9024 A  | 46         | yes |
| Base backplane LB 9022 E                                    | Extension backplane LB 9024 A  | 46         | yes |
| Base backplane LB 9023 A                                    | Extension backplane LB 9025 A  | 16         | no  |
| Base backplane LB 9026 A                                    | Extension backplane LB 9027 A  | 32         | no  |
| Redundancy backplane LB 9029 A, cannot be extended          |                                | 12         | yes |
| FOUNDATION fieldbus backplane LB 9035 A, cannot be extended | 5 (for dual-width I/O modules) |            | no  |

Table 1

### Field Units (Enclosures)

Field units or enclosures are designed to meet the requirements of the most demanding hazardous area and industrial environmental applications.

The enclosure is fitted with backplanes to accept dual width or single width I/O modules.

Any I/O module can be inserted into any slot, enabling a mixture of I/O types in one field unit.

Power supplies, gateways or Com Units fit into reserved slots. These are mechanically coded to avoid mix-ups.

The permissible power given in the data sheet concerns the total power consumption determined by the I/O modules. It already includes the power dissipation of the power supply and gateway.

If other consumers featuring a power supply of their own are installed, their power consumption reduces the available power for I/O modules.

Enclosures supplied by Pepperl+Fuchs are built in accordance with the ATEX directive. They will carry a type tag to indicate the temperature class and permissible ambient temperature as well as the permissible installed power.

Edition 912907 (US) / 220718 (EU) 06/2011

IB  
LB-System  
Digital Inputs  
Digital Outputs  
Analog Inputs  
Analog Outputs  
Bus Couplers  
Power Supplies  
Accessories



## GRP Enclosures

Glass fiber reinforced polyester provides high corrosion resistance for both onshore and offshore installations. Electrostatic charge is avoided by a suitable surface resistance.

## Stainless Steel Enclosures

The electropolished stainless steel 316L provides high corrosion resistance for both onshore and offshore installations. The one piece seal is protected from standing water damage by the box's integral rain channel.

## Mounting

### Modules

The various I/O modules are slotted into the backplane.

#### Plug & Play

The configuration data of each I/O module is stored in non-volatile memory. Should a fault develop within a module, it can easily be removed and replaced by a standard unprogrammed I/O module.

As soon as a new module has been plugged in the Com Unit renews the setting of the new I/O module, within a fraction of a second, and the device starts to function immediately. There are no potentiometer settings or software actions required at all.

If the wrong type of module is fitted, this is recognized and does not influence the running operation. This also applies to Com Unit replacement. However, the configuration of the Com Unit must either be loaded from the control system or via the RS 485 service connection. In a redundant system this is carried out automatically.

### Backplanes

The backplanes are supplied ready fitted on a metal plate with clamps for DIN rail fastening.

When mounting the backplanes vertically the power supplies should be positioned at the top to enable improved heat dissipation. Additional ventilation may be required.

## Configuration

LB Remote I/O signal conditioning modules do not feature internal switches or potentiometers.

They are either configured via the control system or via an easy-to-use Windows™ program and the interface in the Com Unit. The setting of each and every module is stored in a non-volatile memory in the Com Unit.

Remote I/O slaves can be configured:

- via PROFIBUS using GSE files
- via bus using FDT/DTM or PDM
- via service bus using a software tool

FOUNDATION fieldbus and Ethernet gateways are configured via their respective busses.

Depending on the Com Unit there are a wide variety of parameters for each module to choose from.

## Self Generating Documentation

The LB Remote I/O software uses the configuration data to compile a full documentation package. Considerable time and cost savings can be realized by utilizing this feature.

## Communication

### HART Communication

The LB Remote I/O range of products supports HART communication. Provided that the control system can also process the HART protocol, direct communication with the field devices via the PROFIBUS is possible. Alternatively a secondary master can be used on the PROFIBUS line.

Depending upon the type of Com Unit, HART communication is also possible via the service bus.

HART communication with any compatible field device is possible from the control room. For this you have to use the software provided by the manufacturer of the field device or any off-the-shelf software, e. g. Emerson AMS, ABB SMARTVISION, Siemens PDM, E+H Fieldcare, and **FACTware™** etc. HART secondary variables can be mapped into the data exchange.

### PROFIBUS DP V1

PROFIBUS DP V1 allows configuration and parameter settings to be conducted using the control system's engineering tool. You can either use the Pepperl+Fuchs DTM for FDT based systems or EDD for Siemens PDM.

### MODBUS via RS 485 or Ethernet

Suitable Com Units are available for control systems that prefer MODBUS RTU or Ethernet with MODBUS TCP.

## Signal Processing

Independent of the data traffic on the system bus, the I/O modules constantly transmit the incoming signals into an internal bus format using the high integrity Manchester code. The reverse is the case for outgoing signals. One task of the Com Unit is to ensure the quick transfer of data to the I/O modules. The internal memory of the Com Unit contains a complete image of the field signals at all times.

As the Com Unit is the only interface between the LB Remote I/O and the standard bus of the main control system, future bus developments in this field can also be taken care of.



## Functionality

### Redundancy

Com Units are fitted with two galvanically isolated bus connections. The system bus interfaces with the DCS or PLC. The service bus is available for commissioning, maintenance and HART communications (version dependant). In a redundant system a second system bus is added.

Pepperl+Fuchs supplies proven redundant systems well established with renowned DCS manufacturers. In most cases a service bus is not required as communication and parameterization can be accomplished via the main bus.

See the "Redundancy" section on page 14 for details.

### Graded Redundancy

As each control system has its own individual requirements, the LB Remote I/O series was provided with a graded redundancy concept.

### Redundant Com Units

Two Com Units can operate in parallel so that a bumpless transition can take place in case of a fault in one of them.

### Redundant Selectors

With the backplanes LB 9022 and LB 9024 both Com Units can access the internal bus via redundant selectors.

### Line Redundancy

A field station features two redundant Com Units. The field bus is also redundant. The transmission lines of the master are connected to the active and passive Com Units via both bus lines. In order to be able to access both bus lines, the master features a voter or two repeaters for the receiving lines.

### Application Redundancy

A field station features two redundant Com Units. To be able to access both bus lines, the master features two redundant interfaces. Both Com Units are active on both external busses. Only one Com Unit is active on the internal bus and can define outputs.

### Power Supply Redundancy

In the case of LB 9022 and LB 9024 backplanes, a two of three power supply redundancy is available. Two power supplies of the type LB 9006 are sufficient to supply the respective backplane with all the modules and the two Com Units. The third power supply is in the standby mode and becomes active in the event of a fault. A diagnostics report informs the DCS of the fault (> software version V6.X).

### Line Fault Detection (LFD)

Almost all LB Remote I/O series I/O modules have a sophisticated line fault detection system. This feature can be enabled or disabled for each channel individually.

## Safety Information

The corresponding data sheets, the Declaration of Conformity, the EC-Type Examination Certificate and applicable certificates (see data sheet) are an integral part of this document.

For information see manuals, operating instructions and [www.pepperl-fuchs.com](http://www.pepperl-fuchs.com).

## Common Technical Data

### Modules

#### Electrical Data

##### Rated Voltage

see individual data sheet

##### Power Consumption

see individual data sheet

#### Mechanical Data

##### Mounting

- Plug-in mounting on backplane
- The modules have to be mounted in appropriate backplanes (LB 9\*\*\*) in Zone 2 or outside hazardous areas. Here, statement of conformity PF 08 CERT 1234 has to be observed. For use in hazardous areas (e. g. Zone 2 or Zone 22) the module must be installed in an appropriate enclosure.

##### Material

Plastic

##### Dimensions

- Single width modules: 16 mm x 100 mm x 103 mm (0.63 in x 3.9 in x 4 in)
- Dual width modules: 32 mm x 100 mm x 103 mm (1.26 in x 3.9 in x 4 in)

##### Protection Degree

IP20 acc. to EN 60529, mounted on backplane

##### Connection

Device plug (accessories)

- removable terminals
- plug with screw flange
- wiring connection:
  - spring terminals: (0.14 mm<sup>2</sup> ... 1.5 mm<sup>2</sup>)
  - screw terminals: (0.08 mm<sup>2</sup> ... 1.5 mm<sup>2</sup>)

##### Labeling

Space for labeling on the front

##### Ambient Conditions

###### Ambient Temperature

- -20 °C ... 60 °C (-4 °F ... 140 °F)
- -20 °C ... 70 °C (-4 °F ... 158 °F), non-Ex devices

###### Storage Temperature

-25 °C ... 85 °C (-13 °F ... 185 °F)

LB-System

Digital Inputs

Digital Outputs

Analog Inputs

Analog Outputs

Bus Couplers

Power Supplies

Accessories

## Reference Conditions for Device Calibration

20 °C (68 °F)

### Relative Humidity

acc. to EN 60068-2-56, 95 %, non-condensing

### Vibration Resistance

acc. to EN 60068-2-6, frequency range 5 Hz ... 500 Hz, amplitude 5 Hz ... 13.2 Hz ± 1.5 mm, 13.2 Hz ... 100 Hz 1 g, sweep rate 1 octave/min, duration 10 sweeps  
5 Hz - 100 Hz - 5 Hz

### Shock Resistance

acc. to EN 60068-2-27, shock type I, shock duration 11 ms, shock amplitude 50 m/s<sup>2</sup>, number of shock directions 6, number of shocks per direction 100

### Damaging Gas

acc. to EN 60068-2-42, for plugs: 21 days in 25 ppm SO<sub>2</sub>, at 25 °C and 75 % rel. humidity, device G3

## Conformity with Standards and Directives

### General

- Isolator modules with explosion protection, mostly with Ex ia IIC/Class I Div. 1, international approvals
- EMC acc. to NAMUR NE21 and EN 61326
- LEDs acc. to NAMUR NE44
- Software acc. to NAMUR NE53
- Switch-on pulse suppression
- Supply voltage 20 V DC to 30 V DC
- Functional safety devices acc. to IEC 61508 (SIL)

## Backplanes

### Electrical Data

#### Rated Voltage

24 V DC

#### Power Consumption

see individual data sheet

### Mechanical Data

#### Mounting

- Installation in Zone 2 or 22, or safe area, see individual data sheet
- Snap-on standard DIN rail acc. to EN 60715. Can be mounted horizontally or vertically.

#### Material

Plastic

#### Dimensions

see individual data sheet

#### Labeling

Snap-on carrier with space for labeling

## Field Units (Enclosures)

### Electrical Data

#### Rated Voltage

24 V DC

#### Power Consumption/Power Dissipation

see individual data sheet

#### Permissible Power for Enclosures

The permissible power per enclosure determines the number of I/O modules that may be fitted to stay within the limits for the maximum temperature inside the enclosure.

| Enclosure dimensions (mm)<br>(W x H x D) | Permissible power P <sub>max</sub> (W)* |               |
|--|---|---------------|
|  | wall mounted                            | free standing |
| 350 x 306 x 215                          | 43                                      | 54            |
| 600 x 400 x 220                          | 75                                      | 101           |
| 600 x 600 x 220                          | 97                                      | 137           |
| 700 x 350 x 220                          | 78                                      | 105           |
| 800 x 800 x 300                          | 176                                     | 246           |
| 800 x 1000 x 300                         | 206                                     | 295           |

\* P<sub>max</sub> at 40 °C (104 °F) ambient temperature and 60 °C inside temperature

P<sub>max</sub> at 50 °C (122 °F) ambient temperature and 60 °C (140 °F) inside the permissible power is halved

Table 2

The following calculation examples are based on the module power consumption. More recently data sheets distinguish between power consumption and power dissipation. The power consumption is used to calculate the permissible load of the power supply. The power dissipation is used to calculate the permissible power inside an enclosure. When the data sheet does not specify any power dissipation use the power consumption to calculate the maximum power inside an enclosure.

### Calculation Example for Enclosure Type LB 9547-S70-0-0-1-0-M (800 x 800 x 300 mm)

#### Assumptions

- Permissible power: 176 W (wall mounted)
- Ambient temperature: 40 °C (104 °F)
- Max. temperature inside: 60 °C (140 °F)
- Temperature class: T4

#### Permissible number of I/O modules

- 20 x LB 4105 (analog output): 60 W or
- 20 x LB 6114 (digital output): 82 W or
- 48 x LB 1101 (digital input): 24 W

**GRP Enclosures**

| Enclosure dimensions (mm)<br>(W x H x D) | Permissible power $P_{max}$ (W)* |
|--|----------------------------------|
| 544 x 271 x 210                          | 34                               |
| 544 x 407 x 210                          | 43                               |
| 544 x 544 x 210                          | 53                               |

\*  $P_{max}$  at 40 °C (104 °F) ambient temperature and 60 °C inside temperature  
 $P_{max}$  at 50 °C (122 °F) ambient temperature and 60 °C (140 °F) inside the permissible power is halved

Table 3

**Calculation Example for Enclosure Type LB 9516-PB0-0-0-1-0-0 (544 x 271 x 210 mm)****Assumptions**

- Permissible power: 17 W
- Ambient temperature: 50 °C (122 °F)
- Max. temperature inside: 60 °C (140 °F)
- Temperature class: T4

**Permissible number of I/O modules**

- 8 x LB 4105 (analog output): 24 W x 0.7 or
- 5 x LB 6114 (digital output) and 2 x LB 1101 (digital input): (20.5 W + 1 W) x 0.7 W or
- 16 x LB 1101 (digital input): 8 W

When the permissible power is much larger than the power consumption use the values from the data sheet.

When the permissible power and the power consumption are much closer as in the second example, the calculation can use a factor of 0.7. The factor of 0.7 is based on DIN IEC 60364-7-718; VDE 0100-718:2008-05.

**Mechanical Data****Mounting**

Installation in Zone 2 and Zone 22, or Class I, Div. 2, or safe area, see individual data sheet

**Material****GRP Enclosure**

- Housing: polyester, impact resistant, glass fiber reinforced
- Surface: black molded finish (RAL 9005)
- Cable glands: polyamide (PA)
- Seal: silicon, one piece

**Stainless Steel Enclosure**

- Housing: stainless steel 1.4404/316L
- Surface: electropolished
- Cable glands: polyamide (PA)
- Seal: neoprene, fire resistant, one piece

**Dimensions**

see individual data sheet

**Protection Degree**

IP54 (Zone 2 or 22), IP6X (flammable dust)

Our own IP66 enclosures exceed these minimum requirements.

**Connection**

- Supply: screw terminals, max. 2.5 mm<sup>2</sup>
- Fieldbus interface: depends on the backplane
  - PROFIBUS DP V1 and MODBUS RTU: 9-pin Sub-D connector
  - MODBUS TCP/IP: RJ45 connector
  - FOUNDATION fieldbus: wire clamp terminals, max. 2.5 mm<sup>2</sup>

**Ambient Conditions****Ambient Temperature**

- -20 °C ... 55 °C (-4 °F ... 131 °F) at T4
- -20 °C ... 40 °C (-4 °F ... 104 °F) at T6

**Storage Temperature**

-40 °C ... 70 °C (-40 °F ... 158 °F)

**Accessories****Mounting Accessories**

An extension cable (1 m) is used to make up a substation of two rows mounted side by side or below one another in an enclosure. That way you can build the following maximum slave combinations:

Base backplane and extension backplane each with

- 22 or 24 slots for 1-channel modules or
- 11 or 12 slots for multi-channel modules or a combination thereof to arrive at
- 184 digital I/O max.
- 80 analog I/O max.

**Plugs**

Sensors and actuators are adapted via front end screw plug-in connectors. Wire clamp connections on request. Intrinsically safe and non-intrinsically safe modules can be mounted next to each other. The latter are fitted with covered increased safety connections.

**Bus Connection/Power Supply**

The bus is wired to the left end segment. Power line terminals are to be connected at the right end segments.

Redundant power supply modules allow continued operation even if one of three supply modules should fail.

**Cold Junction Compensation (CJC)/Coding**

A connector with built-in CJC is available for thermocouple measurements. Connectors can be coded mechanically to avoid mix-ups.



LB-System

Digital Inputs

Digital Outputs

Analog Inputs

Analog Outputs

Bus Couplers

Power Supplies

Accessories



## Cabinets

LB Remote I/O products can be mounted in standard enclosures. 384 I/O modules can be fitted depending on the cabinet size. A combination with PLC components in the same cabinet is also possible

### Cabinets 800 mm x 2000 mm x 400 mm (W x H x D)

- Horizontal mounting
  - 8 rows or 4 bus substations
  - 736 digital I/O modules or 320 analog I/O modules
- Vertical mounting
  - 3 rows or 4 substations plus 1 base unit
  - 824 digital I/O modules or 360 analog I/O modules

### Cabinets 800 mm x 2000 mm x 600 mm (W x H x D)

Front and rear access

- Horizontal mounting
  - 2 x 8 rows with a total of 8 bus substations
  - 2 x 736 digital I/O modules or 2 x 320 analog I/O modules
- Vertical mounting
  - 2 x 3 rows with a total of 8 bus substations plus 2 base units
  - 2 x 824 digital I/O modules or 2 x 360 analog I/O modules

## Software

The following software is available:

- GSE files
- DD files for Siemens PDM
- Fhx files for Emerson DeltaV
- **PACT<sub>ware</sub>**<sup>TM</sup> configuration tool
- DTM via internet download
- System drivers at request

For additional details, see accessory section and data sheets. Other accessories at request.

LB-System

Digital Inputs

Digital Outputs

Analog Inputs

Analog Outputs

Bus Couplers

Power Supplies

Accessories

Digital Inputs

| Model Number <sup>1</sup> | Channels | Occupied Slots | Input (Field)      |                                     |                 |                            |                               | Input Ex ia | Input Ex ic | Mounting in Zone 2 and Zone 22 | Mounting in Div. 2 | Page |
|---------------------------|----------|----------------|--------------------|-------------------------------------|-----------------|----------------------------|-------------------------------|-------------|-------------|--------------------------------|--------------------|------|
|                           |          |                | NAMUR/Dry Contacts | Frequency and Direction of Rotation | Up/Down Counter | Line Fault Detection (LFD) | Active Digital Signal 24 V DC |             |             |                                |                    |      |
| LB 1001 A                 | 2        | 1              | ■                  |                                     |                 | ■                          |                               | ■           | ■           |                                | 112                |      |
| LB 1002 A                 | 3        | 1              | ■                  |                                     |                 | ■                          |                               | ■           | ■           |                                | 113                |      |
| LB 1003 *                 | 1        | 1              | ■                  | ■                                   | ■               | ■                          |                               | ■           | ■           |                                | 114                |      |
| LB 1008 A                 | 8        | 2              | ■                  |                                     |                 | ■                          | ■                             | ■           | ■           |                                | 115                |      |
| LB 1015 A                 | 15       | 2              |                    |                                     |                 |                            | ■                             |             | ■           |                                | 116                |      |
| LB 1101 A                 | 2        | 1              | ■                  |                                     |                 | ■                          |                               | ■           | ■           | ■                              | 117                |      |
| LB 1102 A                 | 3        | 1              | ■                  |                                     |                 | ■                          |                               | ■           | ■           | ■                              | 118                |      |
| LB 1103 *                 | 1        | 1              | ■                  | ■                                   | ■               | ■                          |                               | ■           | ■           | ■                              | 119                |      |
| LB 1108 A                 | 8        | 2              | ■                  |                                     |                 | ■                          |                               | ■           | ■           | ■                              | 120                |      |

<sup>1</sup> LB 1007 A, LB 1014 A upon enquiry

  
**LB-System**  
**Digital Inputs**  
**Digital Outputs**  
**Analog Inputs**  
**Analog Outputs**  
**Bus Couplers**  
**Power Supplies**  
**Accessories**





LB-System

Digital Inputs

Digital Outputs

Analog Inputs

Analog Outputs

Bus Couplers

Power Supplies

Accessories

**Features**

- 2-channel
- Dry contact or NAMUR inputs
- Galvanic isolation between channels and the bus
- Device installation permissible in Zone 2 or 22 and in the safe area
- Module can be exchanged under voltage (hot swap)
- Positive or negative logic selectable
- Simulation mode for service operations (forcing)
- Line fault detection (LFD)
- Permanently self-monitoring
- EMC acc. to NAMUR NE 21

**Function**

The device accepts up to 2 digital input signals of NAMUR sensors or mechanical contacts from the field.

Open or short circuit line fault alarms are detected.

The inputs are galvanically isolated from each other, from the bus and the power supply (EN 60079-11).

**Technical data**

**Supply**

Rated voltage 12 V DC, only in connection with the power supplies LB 9\*\*\*

Power consumption 0.5 W

**Input**

Number of channels 2

Rated values acc. to EN 60947-5-6 (NAMUR)

Switching point/switching hysteresis 1.2 ... 2.1 mA/± 0.2 mA

Line fault detection option: On/Off, for each channel  
 mechanical switches: see connection diagram  
 NAMUR proximity switches: no replacement network required  
 switching points:  
 - short circuit: typical < 360 Ω, certain < 100 Ω  
 - open circuit: typical < 0.35 mA, certain < 0.05 mA

Minimum pulse duration 20 μs

**Ambient conditions**

Ambient temperature -20 ... 60 °C (-4 ... 140 °F), 70 °C (non-Ex)

**Mechanical specifications**

Mass approx. 110 g

Dimensions 16 x 100 x 103 mm (0.63 x 3.9 x 4 in)

**Data for application in connection with Ex-areas**

Supply only in connection with the power supplies LB 9\*\*\*

Declaration of conformity PF 08 CERT 1234

Group, category, type of protection, temperature classification Ex II 3G Ex nA [ic] IIC T4

Directive conformity

Directive 94/9/EC EN 60079-0, EN 60079-11, EN 60079-15

**International approvals**

IECEx approval BVS 09.0037X

**Diagrams**

Front view

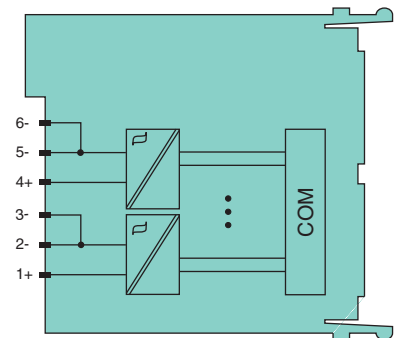
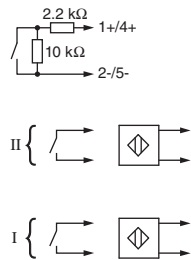
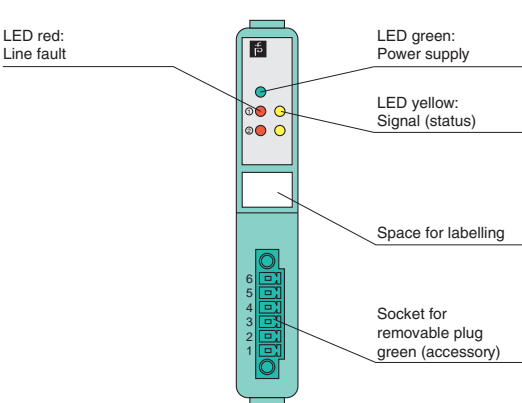

Zone 2

Edition 912907 (US) / 220718 (EU) 06/2011

| Technical data  |  |
|---|--|
| <b>Supply</b>   |  |
| Rated voltage   | 12 V DC, only in connection with the power supplies LB 9***  |
| Power consumption   | 0.5 W  |
| <b>Input</b>  |  |
| Number of channels  | 3  |
| Rated values  | acc. to EN 60947-5-6 (NAMUR)   |
| Switching point/switching hysteresis                            | 1.2 ... 2.1 mA ± 0.2 mA  |
| Line fault detection  | option: On/Off, for each channel<br>mechanical switches: see connection diagram<br>NAMUR proximity switches: no replacement network required<br>switching points:<br>- short circuit: typical < 360 Ω, certain < 100 Ω<br>- open circuit: typical < 0.35 mA, certain < 0.05 mA |
| Minimum pulse duration  | 20 μs  |
| <b>Ambient conditions</b>                                       |  |
| Ambient temperature   | -20 ... 60 °C (-4 ... 140 °F), 70 °C (non-Ex)  |
| <b>Mechanical specifications</b>                                |  |
| Mass  | approx. 90 g   |
| Dimensions  | 16 x 100 x 103 mm (0.63 x 3.9 x 4 in)  |
| <b>Data for application in connection with Ex-areas</b>         |  |
| Supply  | only in connection with the power supplies LB 9***   |
| Declaration of conformity                                       | PF 08 CERT 1234  |
| Group, category, type of protection, temperature classification | ⊕ II 3G Ex nA [ic] IIC T4  |
| Directive conformity  |  |
| Directive 94/9/EC   | EN 60079-0, EN 60079-11, EN 60079-15   |
| <b>International approvals</b>                                  |  |
| IECEx approval  | BVS 09.0037X   |

- Features**
- 3-channel
  - Dry contact or NAMUR inputs
  - Galvanic isolation between inputs and bus (group isolation)
  - Device installation permissible in Zone 2 or 22 and in the safe area
  - Module can be exchanged under voltage (hot swap)
  - Positive or negative logic selectable
  - Simulation mode for service operations (forcing)
  - Line fault detection (LFD)
  - Permanently self-monitoring
  - EMC acc. to NAMUR NE 21

**Function**

The device accepts up to 3 digital input signals of NAMUR sensors or mechanical contacts from the field.

Open or short circuit line fault alarms are detected.

The inputs are galvanically isolated from the bus and the power supply (EN 60079-11).

**Diagrams**

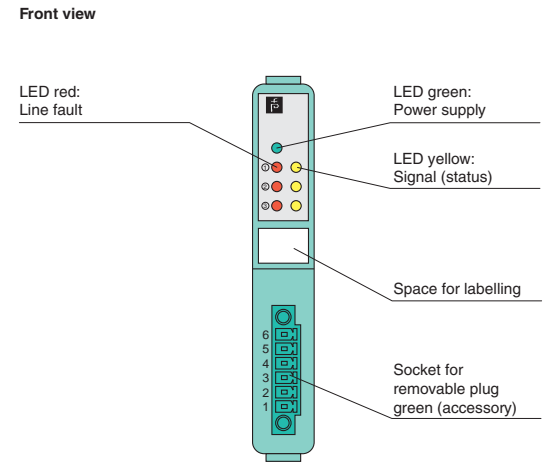
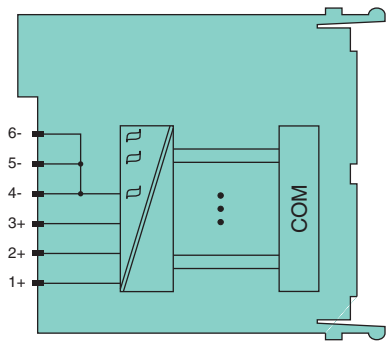
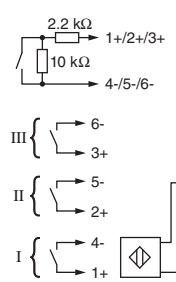

Edition 912907 (US) / 220718 (EU) 06/2011

Subject to modifications without notice

Pepperl+Fuchs Group  
www.pepperl-fuchs.com

USA: +1 330 486 0002  
pa-info@us.pepperl-fuchs.com

Germany: +49 621 776 2222  
pa-info@de.pepperl-fuchs.com

Copyright Pepperl+Fuchs  
Singapore: +65 6779 9091  
pa-info@sg.pepperl-fuchs.com

LB-System  
Digital Inputs  
Digital Outputs  
Analog Inputs  
Analog Outputs  
Bus Couplers  
Power Supplies  
Accessories

LB-System

Digital Inputs

Digital Outputs

Analog Inputs

Analog Outputs

Bus Couplers

Power Supplies

Accessories

**Features**

- 1-channel
- Input for frequency, counter, direction of rotation
- Digital input max. 15 kHz for LB 1003 A
- Digital input max. 400 Hz for LB 1003 C
- Device installation permissible in Zone 2 or 22 and in the safe area
- Module can be exchanged under voltage (hot swap)
- Positive or negative logic selectable
- Simulation mode for service operations (forcing)
- Line fault detection (LFD)
- Permanently self-monitoring
- EMC acc. to NAMUR NE 21

**Function**

The device accepts digital input signals of NAMUR sensors or mechanical contacts from the field.

Open or short circuit line fault alarms are detected.

The inputs are galvanically isolated from the bus and the power supply (EN 60079-11).

**Technical data**

**Supply**

Rated voltage 12 V DC, only in connection with the power supplies LB 9\*\*\*

Power consumption 0.6 W

**Input**

Number of channels 1

Rated values acc. to EN 60947-5-6 (NAMUR)

Switching point/switching hysteresis 1.2 ... 2.1 mA/± 0.2 mA

Line fault detection option: On/Off, for each channel  
 mechanical switches: see connection diagram  
 NAMUR proximity switches: no replacement network required  
 switching points:  
 - short circuit: typical < 360 Ω, certain < 100 Ω  
 - open circuit: typical < 0.35 mA, certain < 0.05 mA

Operating frequency 0 ... 15 kHz/400 Hz

**Ambient conditions**

Ambient temperature -20 ... 60 °C (-4 ... 140 °F), 70 °C (non-Ex)

**Mechanical specifications**

Mass approx. 90 g

Dimensions 16 x 100 x 103 mm (0.63 x 3.9 x 4 in)

**Data for application in connection with Ex-areas**

Supply only in connection with the power supplies LB 9\*\*\*

Declaration of conformity PF 08 CERT 1234

Group, category, type of protection, temperature classification Ex II 3G Ex nA [ic] IIC T4

Directive conformity

Directive 94/9/EC EN 60079-0, EN 60079-11, EN 60079-15

**International approvals**

IECEx approval BVS 09.0037X

**Diagrams**

Front view

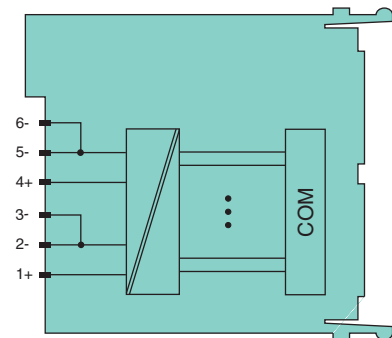
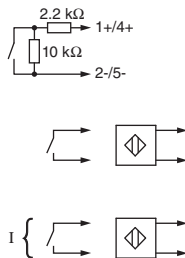
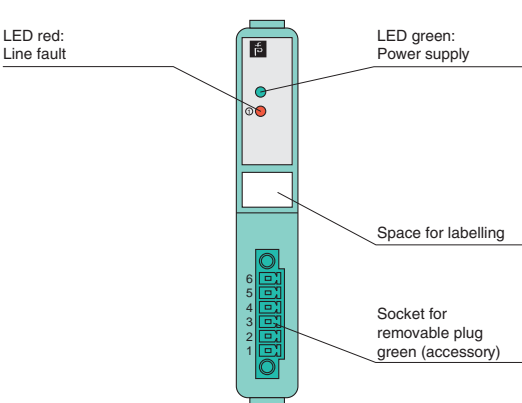

Zone 2

Edition 912907 (US) / 220718 (EU) 06/2011



**Technical data**

|   |   |
|---|---|
| <b>Supply</b>   |   |
| Rated voltage   | 12 V DC, only in connection with the power supplies LB 9***                         |
| Power consumption   | 0.7 W   |
| <b>Input</b>  |   |
| Number of channels  | 8   |
| Rated values  | acc. to EN 60947-5-6 (NAMUR)  |
| Switching point/switching hysteresis                            | 1.2 ... 2.1 mA/± 0.2 mA   |
| Digital signals (active)  | 24 V      5 V   |
| Switching point: ON   | > 8 V      > 2.7 V  |
| Switching point: OFF  | < 3 V      < 2.3 V  |
| Line fault detection  | option: On/Off, for each channel<br>active input without line fault detection (LFD) |
| Minimum pulse duration  | 1 ms  |
| <b>Ambient conditions</b>                                       |   |
| Ambient temperature   | -20 ... 60 °C (-4 ... 140 °F), 70 °C (non-Ex)                                       |
| <b>Mechanical specifications</b>                                |   |
| Mass  | approx. 130 g   |
| Dimensions  | 32 x 100 x 103 mm (1.26 x 3.9 x 4 in)   |
| <b>Data for application in connection with Ex-areas</b>         |   |
| Supply  | only in connection with the power supplies LB 9***                                  |
| Declaration of conformity                                       | PF 08 CERT 1234   |
| Group, category, type of protection, temperature classification | ⊕ II 3G Ex nA [ic] IIC T4   |
| <b>Directive conformity</b>                                     |   |
| Directive 94/9/EC   | EN 60079-0, EN 60079-11, EN 60079-15  |
| <b>International approvals</b>                                  |   |
| IECEx approval  | BVS 09.0037X  |

**Features**

- 8-channel
- Dry contact or NAMUR inputs
- Galvanic isolation between inputs and bus (group isolation)
- Device installation permissible in Zone 2 or 22 and in the safe area
- Module can be exchanged under voltage (hot swap)
- Positive or negative logic selectable
- Simulation mode for service operations (forcing)
- Line fault detection (LFD)
- Permanently self-monitoring
- EMC acc. to NAMUR NE 21

**Function**

The device accepts digital input signals of NAMUR sensors or mechanical contacts from the field. It can be set to read active 24 V or 5 V DC inputs.

Open or short circuit line fault alarms are detected (not for active inputs).

The inputs are galvanically isolated from the bus and the power supply (EN 60079-11).

**Diagrams**

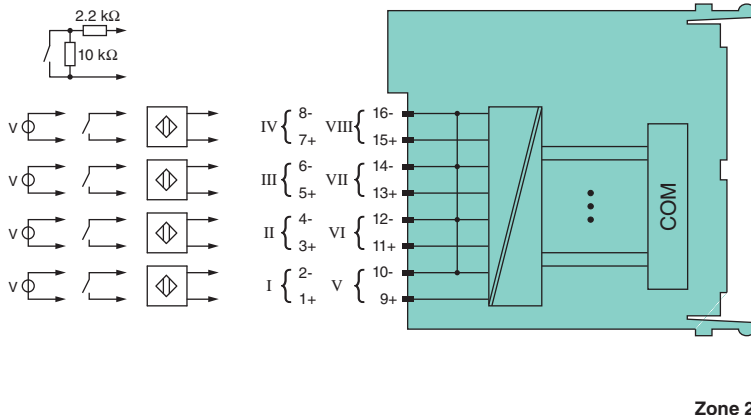

Front view

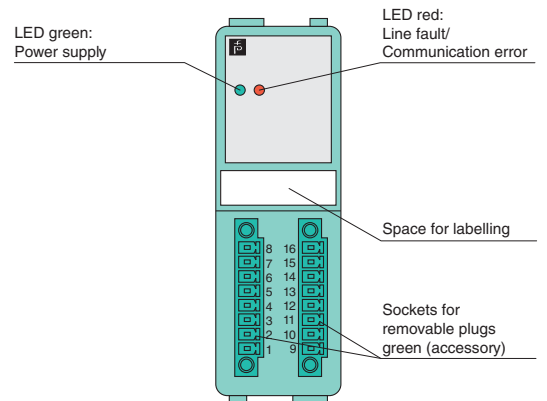

Edition 912907 (US) / 220718 (EU) 06/2011



LB-System

Digital Inputs

Digital Outputs

Analog Inputs

Analog Outputs

Bus Couplers

Power Supplies

Accessories

**Features**

- 15-channel
- Active digital signal 24 V DC
- Galvanic isolation between inputs and bus (group isolation)
- Device installation permissible in Zone 2 or 22 and in the safe area
- Positive or negative logic selectable
- Simulation mode for service operations (forcing)
- Permanently self-monitoring
- EMC acc. to NAMUR NE 21

**Function**

The device accepts 24 V status information from the field. The inputs are galvanically isolated from the bus and the power supply (EN 60079-11).

**Technical data**

**Supply**

Rated voltage 12 V DC, only in connection with the power supplies LB 9\*\*\*

Power consumption 0.6 W

**Input**

Number of channels 15  
Digital signals (active) 24 V DC (30 V max.)

Switching point: ON  $\geq 8$  V

Switching point: OFF  $\leq 4$  V

Input resistance 10 k $\Omega$

Minimum pulse duration 40 ms

Step response approx. 40 ms (0 to 24 V)

**Ambient conditions**

Ambient temperature -20 ... 60 °C (-4 ... 140 °F), 70 °C (non-Ex)

**Mechanical specifications**

Mass approx. 130 g

Dimensions 32 x 100 x 103 mm (1.26 x 3.9 x 4 in)

**Data for application in connection with Ex-areas**

Supply only in connection with the power supplies LB 9\*\*\*

Declaration of conformity PF 08 CERT 1234

Group, category, type of protection, temperature classification  $\text{Ex}$  II 3 G Ex nA IIC T4

Directive conformity

Directive 94/9/EC EN 60079-0, EN 60079-15

**International approvals**

IECEx approval BVS 09.0037X

**Diagrams**

Front view

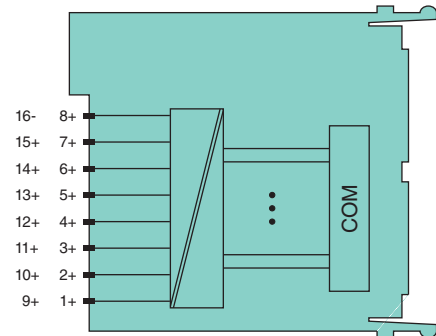
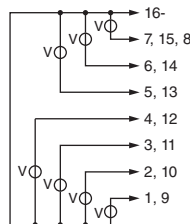
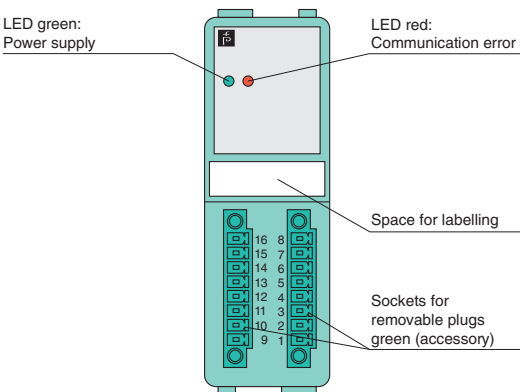

Zone 2

Edition 912907 (US) / 220718 (EU) 06/2011



| Technical data  |  |
|---|--|
| <b>Supply</b>   |  |
| Rated voltage   | 12 V DC, only in connection with the power supplies LB 9***  |
| Power consumption   | 0.5 W  |
| <b>Input</b>  |  |
| Number of channels  | 2  |
| Rated values  | acc. to EN 60947-5-6 (NAMUR)   |
| Switching point/switching hysteresis                            | 1.2 ... 2.1 mA ± 0.2 mA  |
| Line fault detection  | option: On/Off, for each channel<br>mechanical switches: see connection diagram<br>NAMUR proximity switches: no replacement network required<br>switching points:<br>- short circuit: typical < 360 Ω, certain < 100 Ω<br>- open circuit: typical < 0.35 mA, certain < 0.05 mA |
| Minimum pulse duration  | 20 μs  |
| <b>Ambient conditions</b>                                       |  |
| Ambient temperature   | -20 ... 60 °C (-4 ... 140 °F)  |
| <b>Mechanical specifications</b>                                |  |
| Mass  | approx. 110 g  |
| Dimensions  | 16 x 100 x 103 mm (0.63 x 3.9 x 4 in)  |
| <b>Data for application in connection with Ex-areas</b>         | see page 121 for entity parameters   |
| EC-Type Examination Certificate                                 | PTB 03 ATEX 2042   |
| Group, category, type of protection                             | ⊕ II (1) G [Ex ia] IIC, II (1) D [Ex iaD]  |
| Supply  | only in connection with the power supplies LB 9***   |
| Declaration of conformity                                       | PF 08 CERT 1234  |
| Group, category, type of protection, temperature classification | ⊕ II 3 G Ex nA IIC T4  |
| Directive conformity  |  |
| Directive 94/9/EC   | EN 60079-0, EN 60079-11, EN 60079-15, EN 60079-26, EN 61241-0, EN 61241-11   |
| <b>International approvals</b>                                  |  |
| UL approval   | E106378  |
| IECEx approval  | BVS 09.0037X, BVS 08.0011X   |

**Features**

- 2 channels
- Inputs Ex ia
- Dry contact or NAMUR inputs
- Galvanic isolation between channels and the bus
- Installation in Zone 2 and 22 or Div. 2 and safe area
- Module can be exchanged under voltage (hot swap)
- Positive or negative logic selectable
- Simulation mode for service operations (forcing)
- Line fault detection (LFD)
- Permanently self-monitoring
- EMC acc. to NAMUR NE 21

**Function**

The device accepts digital input signals of NAMUR sensors or mechanical contacts from the hazardous area.

Open or short circuit line fault alarms are detected.

The intrinsically safe inputs are galvanically isolated from the bus and the power supply (EN 60079-11).

**Diagrams**

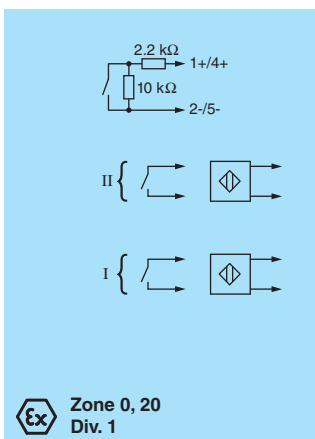

**Ex** Zone 0, 20 Div. 1

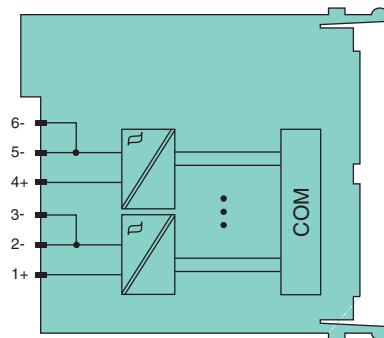

Zone 2 Div. 2

Front view

LED red: Line fault

LED green: Power supply

LED yellow: Signal (status)

Space for labelling

Socket for removable plug blue (accessory)

Edition 912907 (US) / 220718 (EU) 06/2011

Subject to modifications without notice

Pepperl+Fuchs Group  
www.pepperl-fuchs.com

USA: +1 330 486 0002  
pa-info@us.pepperl-fuchs.com

Germany: +49 621 776 2222  
pa-info@de.pepperl-fuchs.com

Copyright Pepperl+Fuchs  
Singapore: +65 6779 9091  
pa-info@sg.pepperl-fuchs.com



LB-System

Digital Inputs

Digital Outputs

Analog Inputs

Analog Outputs

Bus Couplers

Power Supplies

Accessories

**Features**

- 3-channel
- Inputs Ex ia
- Dry contact or NAMUR inputs
- Galvanic isolation between inputs and bus (group isolation)
- Installation in Zone 2 and 22 or Div. 2 and safe area
- Module can be exchanged under voltage (hot swap)
- Positive or negative logic selectable
- Simulation mode for service operations (forcing)
- Line fault detection (LFD)
- Permanently self-monitoring
- EMC acc. to NAMUR NE 21

**Function**

The device accepts up to 3 digital input signals of NAMUR sensors or mechanical contacts from the hazardous area.

Open or short circuit line fault alarms are detected.

The inputs are galvanically isolated from the bus and the power supply (EN 60079-11).

**Technical data**

**Supply**

Rated voltage 12 V DC, only in connection with the power supplies LB 9\*\*\*

Power consumption 0.5 W

**Input**

Number of channels 3

Rated values acc. to EN 60947-5-6 (NAMUR)

Switching point/switching hysteresis 1.2 ... 2.1 mA/± 0.2 mA

**Line fault detection**

option: On/Off, for each channel  
 mechanical switches: see connection diagram  
 NAMUR proximity switches: no replacement network required  
 switching points:  
 - short circuit: typical < 360 Ω, certain < 100 Ω  
 - open circuit: typical < 0.35 mA, certain < 0.05 mA

Minimum pulse duration 20 μs

**Ambient conditions**

Ambient temperature -20 ... 60 °C (-4 ... 140 °F)

**Mechanical specifications**

Mass approx. 90 g

Dimensions 16 x 100 x 103 mm (0.63 x 3.9 x 4 in)

**Data for application in connection with Ex-areas** see page 121 for entity parameters

EC-Type Examination Certificate PTB 03 ATEX 2042

Group, category, type of protection Ⓜ II (1) G [Ex ia] IIC, II (1) D [Ex iaD]

Supply only in connection with the power supplies LB 9\*\*\*

Declaration of conformity PF 08 CERT 1234

Group, category, type of protection, temperature classification Ⓜ II 3 G Ex nA IIC T4

Directive conformity

Directive 94/9/EC EN 60079-0, EN 60079-11, EN 60079-15, EN 60079-26, EN 61241-0, EN 61241-11

**International approvals**

UL approval E106378

IECEX approval BVS 09.0037X, BVS 08.0011X

**Diagrams**

Front view

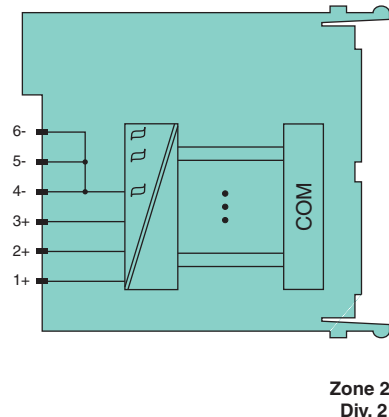
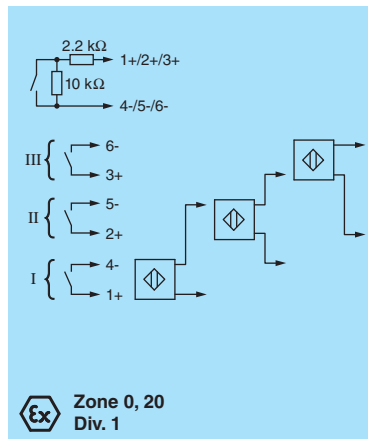
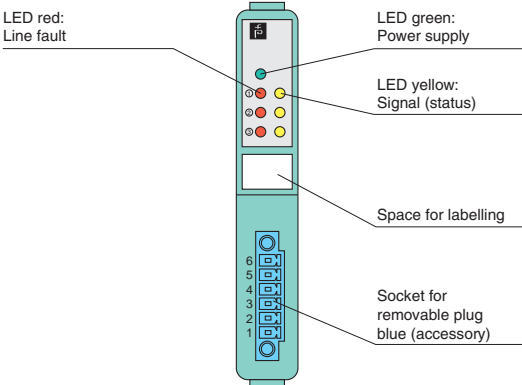

Zone 0, 20 Div. 1

Zone 2 Div. 2

Edition 912907 (US) / 220718 (EU) 06/2011

| Technical data  |  |
|---|--|
| <b>Supply</b>   |  |
| Rated voltage   | 12 V DC, only in connection with the power supplies LB 9***  |
| Power consumption   | 0.6 W  |
| <b>Input</b>  |  |
| Number of channels  | 1  |
| Rated values  | acc. to EN 60947-5-6 (NAMUR)   |
| Switching point/switching hysteresis                            | 1.2 ... 2.1 mA ± 0.2 mA  |
| Line fault detection  | option: On/Off, for each channel<br>mechanical switches: see connection diagram<br>NAMUR proximity switches: no replacement network required<br>switching points:<br>- short circuit: typical < 360 Ω, certain < 100 Ω<br>- open circuit: typical < 0.35 mA, certain < 0.05 mA |
| Operating frequency   | 0 ... 15 kHz/400 Hz  |
| <b>Ambient conditions</b>                                       |  |
| Ambient temperature   | -20 ... 60 °C (-4 ... 140 °F)  |
| <b>Mechanical specifications</b>                                |  |
| Mass  | approx. 90 g   |
| Dimensions  | 16 x 100 x 103 mm (0.63 x 3.9 x 4 in)  |
| <b>Data for application in connection with Ex-areas</b>         | see page 121 for entity parameters   |
| EC-Type Examination Certificate                                 | PTB 03 ATEX 2042   |
| Group, category, type of protection                             | ⊕ II (1) G [Ex ia] IIC, II (1) D [Ex iaD]  |
| Supply  | only in connection with the power supplies LB 9***   |
| Declaration of conformity                                       | PF 08 CERT 1234  |
| Group, category, type of protection, temperature classification | ⊕ II 3 G Ex nA IIC T4  |
| Directive conformity  |  |
| Directive 94/9/EC   | EN 60079-0, EN 60079-11, EN 60079-15, EN 60079-26, EN 61241-0, EN 61241-11   |
| <b>International approvals</b>                                  |  |
| UL approval   | E106378  |
| IECEx approval  | BVS 09.0037X, BVS 08.0011X   |

**Features**

- 1-channel
- Input Ex ia
- Input for frequency, counter, direction of rotation
- Digital input max. 15 kHz for LB 1103 A
- Digital input max. 400 Hz for LB 1103 C
- Installation in Zone 2 and 22 or Div. 2 and safe area
- Module can be exchanged under voltage (hot swap)
- Positive or negative logic selectable
- Simulation mode for service operations (forcing)
- Line fault detection (LFD)
- Permanently self-monitoring
- EMC acc. to NAMUR NE 21

**Function**

The device accepts digital input signals of NAMUR sensors or mechanical contacts from the hazardous area.

Open or short circuit line fault alarms are detected.

The intrinsically safe inputs are galvanically isolated from the bus and the power supply (EN 60079-11).

**Diagrams**

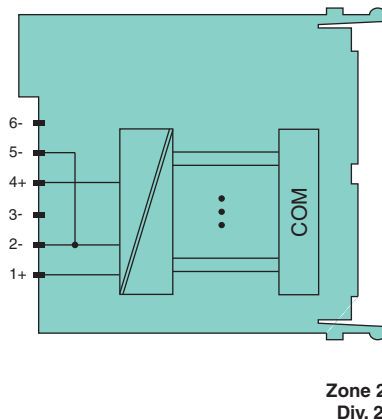
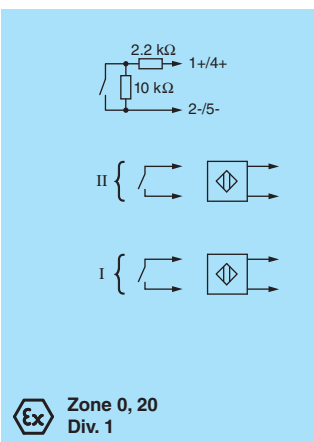

Front view

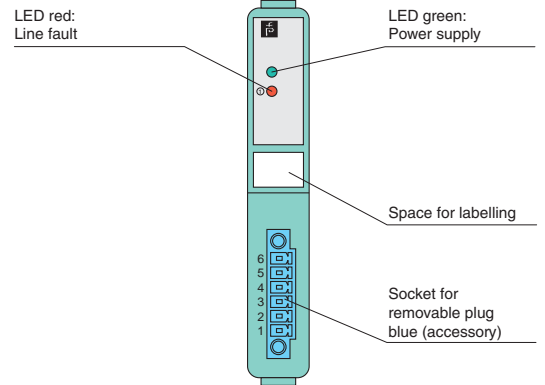

Edition 912907 (US) / 220718 (EU) 06/2011

**Ex** Zone 0, 20 Div. 1

Subject to modifications without notice

Pepperl+Fuchs Group  
www.pepperl-fuchs.com

USA: +1 330 486 0002  
pa-info@us.pepperl-fuchs.com

Germany: +49 621 776 2222  
pa-info@de.pepperl-fuchs.com

Copyright Pepperl+Fuchs  
Singapore: +65 6779 9091  
pa-info@sg.pepperl-fuchs.com



LB-System

Digital Inputs

Digital Outputs

Analog Inputs

Analog Outputs

Bus Couplers

Power Supplies

Accessories





LB-System

Digital Inputs

Digital Outputs

Analog Inputs

Analog Outputs

Bus Couplers

Power Supplies

Accessories

**Features**

- 8-channel
- Inputs Ex ia
- Dry contact or NAMUR inputs
- Galvanic isolation between inputs and bus (group isolation)
- Installation in Zone 2 and 22 or Div. 2 and safe area
- Module can be exchanged under voltage (hot swap)
- Positive or negative logic selectable
- Simulation mode for service operations (forcing)
- Line fault detection (LFD)
- Permanently self-monitoring
- EMC acc. to NAMUR NE 21

**Function**

The device accepts digital input signals of NAMUR sensors or mechanical contacts from the hazardous area.

Open or short circuit line fault alarms are detected.

The inputs are galvanically isolated from the bus and the power supply (EN 60079-11).

**Technical data**

**Supply**

Rated voltage 12 V DC, only in connection with the power supplies LB 9\*\*\*

Power consumption 0.7 W

**Input**

Number of channels 8

Rated values acc. to EN 60947-5-6 (NAMUR)

Switching point/switching hysteresis 1.2 ... 2.1 mA/± 0.2 mA

**Line fault detection**

option: On/Off, for each channel  
 mechanical switches: see connection diagram  
 NAMUR proximity switches: no replacement network required  
 switching points:  
 - short circuit: typical < 360 Ω, certain < 100 Ω  
 - open circuit: typical < 0.35 mA, certain < 0.05 mA

Minimum pulse duration 1 ms

**Ambient conditions**

Ambient temperature -20 ... 60 °C (-4 ... 140 °F)

**Mechanical specifications**

Mass approx. 130 g

Dimensions 32 x 100 x 103 mm (1.26 x 3.9 x 4 in)

**Data for application in connection with Ex-areas** see page 121 for entity parameters

EC-Type Examination Certificate PTB 03 ATEX 2042

Group, category, type of protection Ⓜ II (1) G [Ex ia] IIC, II (1) D [Ex iaD]

Supply only in connection with the power supplies LB 9\*\*\*

Declaration of conformity PF 08 CERT 1234

Group, category, type of protection, temperature classification Ⓜ II 3 G Ex nA IIC T4

Directive conformity

Directive 94/9/EC EN 60079-0, EN 60079-11, EN 60079-15, EN 60079-26, EN 61241-0, EN 61241-11

**International approvals**

UL approval E106378

IECEX approval BVS 09.0037X, BVS 08.0011X

**Diagrams**

Front view

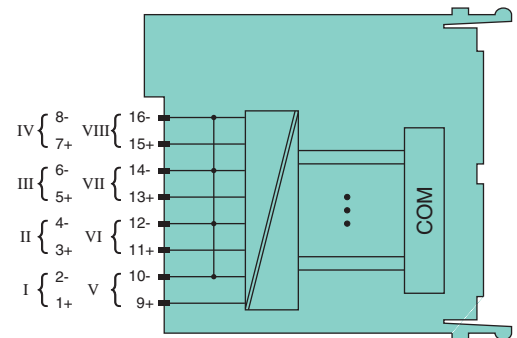
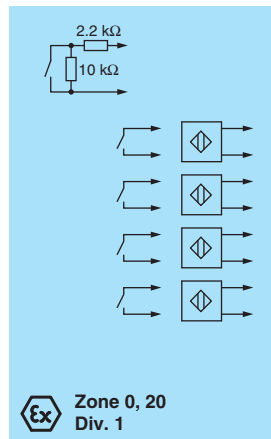
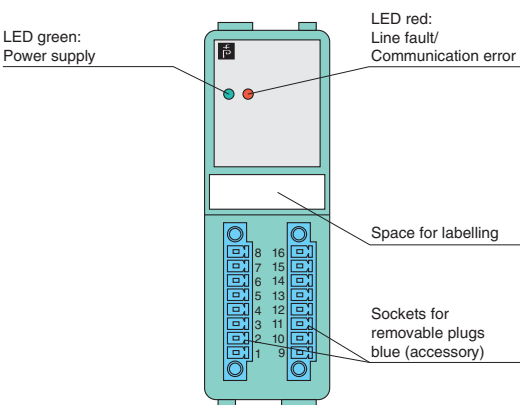

Zone 2 Div. 2

Edition 912907 (US) / 220718 (EU) 06/2011

## ATEX Entity Parameters

| Model Number | Terminals  | $U_o$ (V) | $I_o$ (mA) | $P_o$ (mW) |
|--------------|--|-----------|------------|------------|
| LB 1101 A    | 1+, 2-; 4+, 5-   | 12.6      | 12.8       | 40.1       |
| LB 1102 A    | 1+, 4-; 2+, 5-; 3+, 6-   | 10.5      | 35         | 92         |
| LB 1103 *    | 1+, 2-; 4+, 5-   | 10.5      | 23.3       | 61.2       |
| LB 1108 A    | 1+, 2-; 3+, 4-; 5+, 6-; 7+, 8-;<br>9+, 10-; 11+, 12-; 13+, 14-; 15+, 16- | 14.9      | 15.7       | 58.2       |



LB-System

Digital  
InputsDigital  
OutputsAnalog  
InputsAnalog  
OutputsBus  
CouplersPower  
Supplies

Accessories



Digital Outputs with Position Feedback

| Model Number           | Channels |        | Occupied Slots | Input (Field)      |                            |                   | Output (Field)    |                            |   | SIL | Input Ex ia | Input Ex ic | Output Ex ia | Output Ex ic | Mounting in Zone 2 and Zone 22 | Mounting in Div. 2 | Page |
|------------------------|----------|--------|----------------|--------------------|----------------------------|-------------------|-------------------|----------------------------|---|-----|-------------|-------------|--------------|--------------|--------------------------------|--------------------|------|
|                        | Input    | Output |                | NAMUR/Dry Contacts | Line Fault Detection (LFD) | Electronic Output | Watchdog Function | Line Fault Detection (LFD) |   |     |             |             |              |              |                                |                    |      |
| LB 2002 * 1            | 2        | 1      | 1              | ■                  | ■                          | ■                 | ■                 | ■                          |   | ■   | ■           | ■           | ■            | ■            | ■                              | 124                |      |
| LB 2101 - LB 2113 2    | 2        | 1      | 1              | ■                  | ■                          | ■                 | ■                 | ■                          |   | ■   | ■           | ■           | ■            | ■            | ■                              | 125                |      |
| LB 2101 - LB 2113 SIL2 | 2        | 1      | 1              | ■                  | ■                          | ■                 | ■                 | ■                          | 2 | ■   | ■           | ■           | ■            | ■            | ■                              | 126                |      |

1 LB 2002 A compatible replacement for LB 2002 C (spares available) – new gateways allow LFD test pulse to be switched off

2 LB 2112 A compatible replacement for LB 2112 C (spares available) – new gateways allow LFD test pulse to be switched off

Digital Outputs

| Model Number           | Channels |        | Occupied Slots | Output (Field) |                   |                   |                            | SIL | Output Ex ia | Output Ex ib | Output Ex ic | Output Ex nA | Mounting in Zone 2 and Zone 22 | Mounting in Div. 2 | Page |
|------------------------|----------|--------|----------------|----------------|-------------------|-------------------|----------------------------|-----|--------------|--------------|--------------|--------------|--------------------------------|--------------------|------|
|                        | Input    | Output |                | Relay Output   | Electronic Output | Watchdog Function | Line Fault Detection (LFD) |     |              |              |              |              |                                |                    |      |
| LB 6005 A              |          | 4      | 2              | ■              |                   | ■                 |                            |     |              |              | ■            | ■            |                                | 127                |      |
| LB 6006 A              |          | 8      | 2              | ■              |                   | ■                 |                            |     |              |              | ■            | ■            |                                | 128                |      |
| LB 6008 * 3            |          | 8      | 2              |                | ■                 | ■                 | ■                          | 2   |              | ■            |              | ■            |                                | 129                |      |
| LB 6010 A              |          | 4      | 2              |                | ■                 | ■                 | ■                          |     |              | ■            |              | ■            |                                | 130                |      |
| LB 6010 SIL2           |          | 4      | 2              |                | ■                 | ■                 | ■                          | 2   |              | ■            |              | ■            |                                | 131                |      |
| LB 6101 H              |          | 2      | 1              | ■              |                   | ■                 |                            |     |              |              | ■            | ■            |                                | 132                |      |
| LB 6108 * 4            |          | 8      | 2              |                | ■                 | ■                 | ■                          | 2   |              | ■            |              | ■            | ■                              | 133                |      |
| LB 6110 - LB 6115      |          | 4      | 2              |                | ■                 | ■                 | ■                          |     | ■            |              |              | ■            | ■                              | 134                |      |
| LB 6110 - LB 6115 SIL2 |          | 4      | 2              |                | ■                 | ■                 | ■                          | 2   | ■            |              |              | ■            | ■                              | 135                |      |

3 LB 6008 A compatible replacement for LB 6008 C (spares available) – different drive voltage

4 LB 6108 A compatible replacement for LB 6108 C (spares available) – different drive voltage and IS parameters

Edition 912907 (US) / 220718 (EU) 06/2011



LB-System

Digital Inputs

Digital Outputs

Analog Inputs

Analog Outputs

Bus Couplers

Power Supplies

Accessories



LB-System

Digital Inputs

Digital Outputs

Analog Inputs

Analog Outputs

Bus Couplers

Power Supplies

Accessories

**Features**

- 1 digital output, 2 digital inputs
- Output voltage 24 V, max. internal resistance 210 Ω
- Device installation permissible in Zone 2 or 22 and in the safe area
- Module can be exchanged under voltage (hot swap)
- Positive or negative logic selectable
- Simulation mode for service operations (forcing)
- Line fault detection (LFD)
- Permanently self-monitoring
- Output with watchdog circuit
- EMC acc. to NAMUR NE 21

**Function**

The digital output features 1 output with 2 feedback inputs.

The digital output can control a solenoid valve, a sounder or an indicator (without line fault detection) in the field. Additionally, it accepts 2 digital input signals of NAMUR sensors or mechanical contacts from the field.

Open or short circuit line fault alarms are detected.

The inputs and the output are galvanically isolated from the bus and the power supply (IEC/EN 60079-11).

**Technical data**

|   |  |
|---|--|
| <b>Supply</b>   |  |
| Rated voltage   | 12 V DC, only in connection with the power supplies LB 9***  |
| Power consumption   | 1.8 W  |
| <b>Input</b>  |  |
| Number of channels  | 2  |
| Rated values  | acc. to EN 60947-5-6 (NAMUR)   |
| Switching point/switching hysteresis                            | 1.2 ... 2.1 mA/± 0.2 mA  |
| Line fault detection  | option: On/Off, for each channel<br>mechanical switches: see connection diagram<br>NAMUR proximity switches: no replacement network required<br>switching points:<br>- short circuit: typical < 360 Ω, certain < 100 Ω<br>- open circuit: typical < 0.35 mA, certain < 0.05 mA |
| Internal resistor   | approx. 1 kΩ   |
| <b>Output</b>   |  |
| Number of channels  | 1  |
| Operating frequency   | 0 ... 50 Hz, depending on the process control system   |
| Line fault detection  | option: On/Off, see connection diagram<br>switching points:<br>- short circuit: < 110 Ω<br>- open circuit: > 1200 Ω  |
| Watchdog  | output Off 0.5 s after serious fault   |
| <b>Ambient conditions</b>                                       |  |
| Ambient temperature   | -20 ... 60 °C (-4 ... 140 °F), 70 °C (non-Ex)  |
| <b>Mechanical specifications</b>                                |  |
| Mass  | approx. 110 g  |
| Dimensions  | 16 x 100 x 103 mm (0.63 x 3.9 x 4 in)  |
| <b>Data for application in connection with Ex-areas</b>         |  |
| Supply  | only in connection with the power supplies LB 9***   |
| Declaration of conformity                                       | PF 08 CERT 1234  |
| Group, category, type of protection, temperature classification | ⊕ II 3G Ex nA [ic] IIB T4  |
| <b>Directive conformity</b>                                     |  |
| Directive 94/9/EC   | EN 60079-0, EN 60079-11, EN 60079-15   |
| <b>International approvals</b>                                  |  |
| IECEx approval  | BVS 09.0037X   |

**Diagrams**

Front view

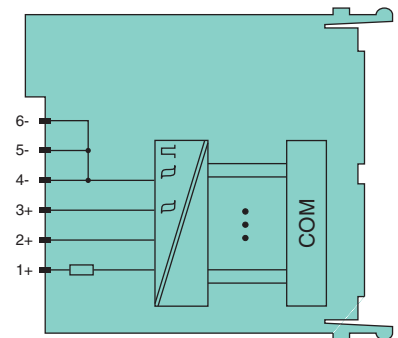
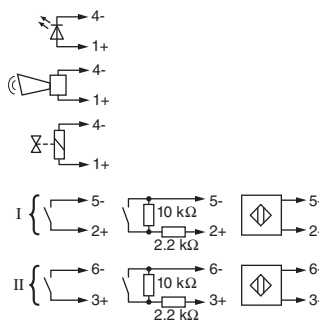
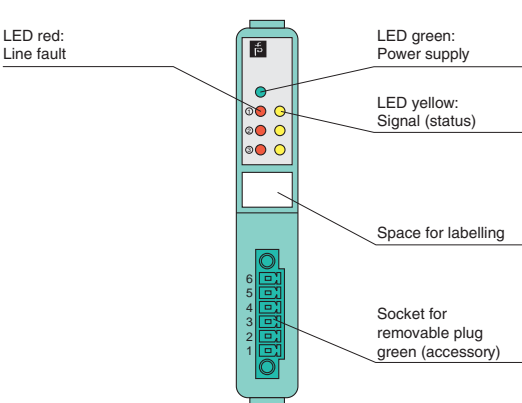

Zone 2

Edition 912907 (US) / 220718 (EU) 06/2011



**Technical data**

**Supply**

|                   |   |
|-------------------|---|
| Rated voltage     | 12 V DC, only in connection with the power supplies LB 9*** |
| Power consumption | 0.52 ... 1.8 W, depending on model                          |

**Input**

|                                      |  |
|--------------------------------------|--|
| Number of channels                   | 2  |
| Rated values                         | acc. to EN 60947-5-6 (NAMUR)   |
| Switching point/switching hysteresis | 1.2 ... 2.1 mA ± 0.2 mA  |
| Line fault detection                 | option: On/Off, for each channel<br>mechanical switches: see connection diagram<br>NAMUR proximity switches: no replacement network required<br>switching points:<br>- short circuit: typical < 360 Ω, certain < 100 Ω<br>- open circuit: typical < 0.35 mA, certain < 0.05 mA |
| Internal resistor                    | approx. 1 kΩ   |

**Output**

|                      |   |
|----------------------|---|
| Number of channels   | 1   |
| Operating frequency  | 0 ... 50 Hz, depending on the process control system                  |
| Line fault detection | option: On/Off, see connection diagram<br>switching points: see table |
| Watchdog             | output Off 0.5 s after serious fault                                  |

**Ambient conditions**

|                     |                               |
|---------------------|-------------------------------|
| Ambient temperature | -20 ... 60 °C (-4 ... 140 °F) |
|---------------------|-------------------------------|

**Mechanical specifications**

|      |               |
|------|---------------|
| Mass | approx. 110 g |
|------|---------------|

|            |                                       |
|------------|---------------------------------------|
| Dimensions | 16 x 100 x 103 mm (0.63 x 3.9 x 4 in) |
|------------|---------------------------------------|

**Data for application in connection with Ex-areas** see page 136 for entity parameters

|   |  |
|---|--|
| EC-Type Examination Certificate                                 | PTB 03 ATEX 2042   |
| Group, category, type of protection                             | ⊕ II (1) G [Ex ia] IIC/IIB, ⊕ II (1) D [Ex iaD]                            |
| Supply  | only in connection with the power supplies LB 9***                         |
| Declaration of conformity                                       | PF 08 CERT 1234  |
| Group, category, type of protection, temperature classification | ⊕ II 3 G Ex nA IIC/IIB T4  |
| <b>Directive conformity</b>                                     |  |
| Directive 94/9/EC   | EN 60079-0, EN 60079-11, EN 60079-15, EN 60079-26, EN 61241-0, EN 61241-11 |
| <b>International approvals</b>                                  |  |
| UL approval   | E106378  |
| IECEx approval  | BVS 09.0037X, BVS 08.0011X   |

**Features**

- 1 digital output, 2 digital inputs
- Inputs and output Ex ia
- Installation in Zone 2 and 22 or Div. 2 and safe area
- Module can be exchanged under voltage (hot swap)
- Positive or negative logic selectable
- Simulation mode for service operations (forcing)
- Line fault detection (LFD)
- Permanently self-monitoring
- Output with watchdog circuit
- EMC acc. to NAMUR NE 21

**Function**

The digital output features 1 output with 2 feedback inputs.

The digital output can control a solenoid valve, a sounder or an indicator (without line fault detection) in the field. Additionally, it accepts 2 digital input signals of NAMUR sensors or mechanical contacts from the field.

Open or short circuit line fault alarms are detected.

The intrinsically safe inputs and the output are galvanically isolated from the bus and the power supply (IEC/EN 60079-11).

**Diagrams**

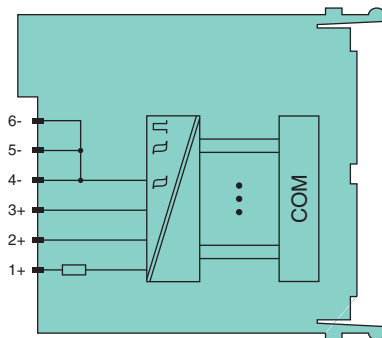
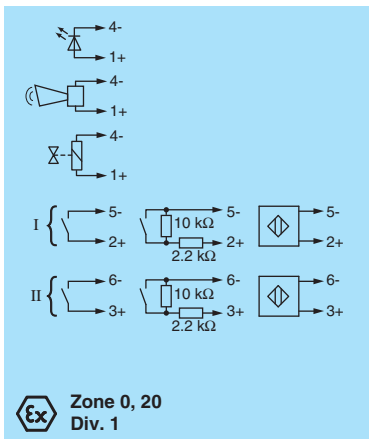

Front view

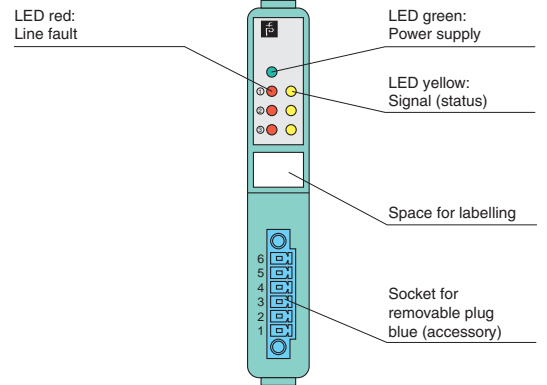

Edition 912907 (US) / 220718 (EU) 06/2011



LB-System

Digital Inputs

Digital Outputs

Analog Inputs

Analog Outputs

Bus Couplers

Power Supplies

Accessories



**Features**

- 1 digital output, 2 digital inputs
- Inputs and output Ex ia
- Installation in Zone 2 and 22 or Div. 2 and safe area
- Module can be exchanged under voltage (hot swap)
- Positive or negative logic selectable
- Simulation mode for service operations (forcing)
- Line fault detection (LFD)
- Permanently self-monitoring
- Output with watchdog circuit
- Output with bus-independent safety shutdown
- EMC acc. to NAMUR NE 21
- Up to SIL2 acc. to IEC 61508

**Function**

The digital output features 1 output with 2 feedback inputs.

The digital output can control a solenoid valve, a sounder or an indicator (without line fault detection) in the field.

Additionally, it accepts 2 digital input signals of NAMUR sensors or mechanical contacts from the field.

The output can be switched off via a contact. This can be used for bus-independent safety applications.

Open or short circuit line fault alarms are detected.

The intrinsically safe inputs and the output are galvanically isolated from the bus and the power supply (IEC/EN 60079-11).

**Technical data**

**Supply**

Rated voltage 12 V DC, only in connection with the power supplies LB 9\*\*\*

Power consumption 0.52 ... 1.8 W, depending on model

**Input**

Number of channels 2

Rated values acc. to EN 60947-5-6 (NAMUR)

Switching point/switching hysteresis 1.2 ... 2.1 mA/± 0.2 mA

Line fault detection option: On/Off, for each channel  
 mechanical switches: see connection diagram  
 NAMUR proximity switches: no replacement network required  
 switching points:  
 - short circuit: typical < 360 Ω, certain < 100 Ω  
 - open circuit: typical < 0.35 mA, certain < 0.05 mA

Internal resistor approx. 1 kΩ

**Output**

Number of channels 1

Operating frequency 0 ... 50 Hz, depending on the process control system

Line fault detection option: On/Off, see connection diagram  
 switching points: see table

Watchdog output Off 0.5 s after serious fault

**Ambient conditions**

Ambient temperature -20 ... 60 °C (-4 ... 140 °F)

**Mechanical specifications**

Mass approx. 110 g

Dimensions 16 x 100 x 103 mm (0.63 x 3.9 x 4 in)

**Data for application in connection with Ex-areas** see page 136 for entity parameters

EC-Type Examination Certificate PTB 03 ATEX 2042

Group, category, type of protection Ⓢ II (1) G [Ex ia] IIC/IIB, Ⓢ II (1) D [Ex iaD]

Supply only in connection with the power supplies LB 9\*\*\*

Declaration of conformity PF 08 CERT 1234

Group, category, type of protection, temperature classification Ⓢ II 3 G Ex nA IIC/IIB T4

**Directive conformity**

Directive 94/9/EC EN 60079-0, EN 60079-11, EN 60079-15, EN 60079-26, EN 61241-0, EN 61241-11

**International approvals**

UL approval E106378

IECEx approval BVS 09.0037X, BVS 08.0011X

**Diagrams**

Front view

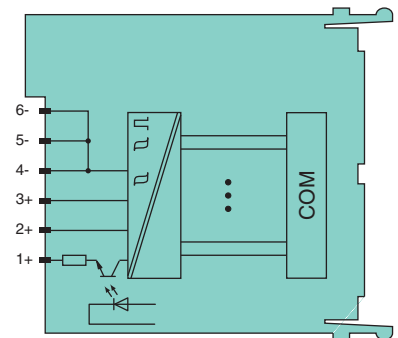
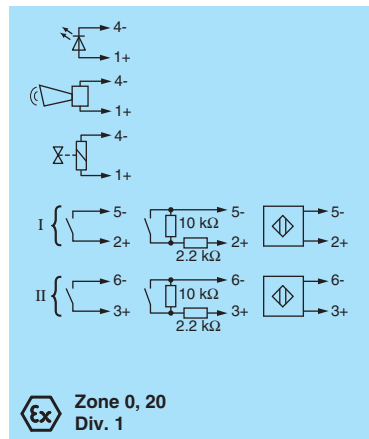
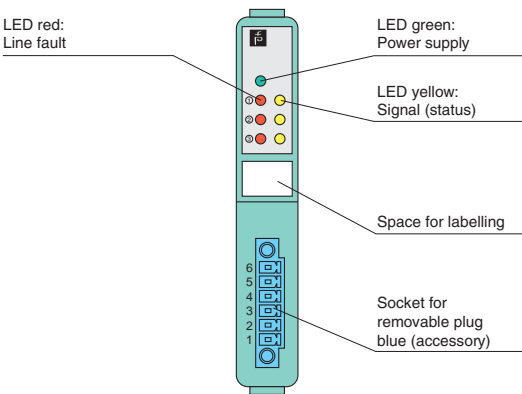

Ex Zone 0, 20 Div. 1

Zone 2 Div. 2

Edition 912907 (US) / 220718 (EU) 06/2011



**Technical data**

|   |   |
|---|---|
| <b>Supply</b>   |   |
| Rated voltage   | 12 V DC, only in connection with the power supplies LB 9*** |
| Power consumption   | 1.2 W   |
| <b>Output</b>   |   |
| Number of channels  | 4   |
| Response time   | 20 ms (depending on bus cycle time)                         |
| Minimal switching capability                                    | ≥ 1 V, ≥ 1 mA   |
| Contact Material  | AgPd gold plated  |
| Watchdog  | output Off 0.5 s after serious fault                        |
| Sampling time   | approx. 6.5 ms  |
| <b>Ambient conditions</b>                                       |   |
| Ambient temperature   | -20 ... 60 °C (-4 ... 140 °F), 70 °C (non-Ex)               |
| <b>Mechanical specifications</b>                                |   |
| Mass  | approx. 130 g   |
| Dimensions  | 32 x 100 x 103 mm (1.26 x 3.9 x 4 in)                       |
| <b>Data for application in connection with Ex-areas</b>         |   |
| Supply  | only in connection with the power supplies LB 9***          |
| Declaration of conformity                                       | PF 08 CERT 1234   |
| Group, category, type of protection, temperature classification | Ⓜ II 3 G Ex nA nC IIC T4                                    |
| <b>Directive conformity</b>                                     |   |
| Directive 94/9/EC   | EN 60079-0, EN 60079-15                                     |
| <b>International approvals</b>                                  |   |
| UL approval   | E106378   |
| IECEx approval  | BVS 09.0037X  |

**Features**

- 4-channel
- Device installation permissible in Zone 2 or 22 and in the safe area
- Module can be exchanged under voltage (hot swap)
- On/Off delay
- Positive or negative logic selectable
- Output with watchdog circuit
- Simulation mode for service operations (forcing)
- Permanently self-monitoring
- EMC acc. to NAMUR NE 21

**Function**

The relay output features 4 independent channels.

The relay output can be used to switch solenoids, sounders, or lamps.

It can also perform general switching operations, e.g. to switch auxiliary power circuits.

The outputs are galvanically isolated from the bus and the power supply (EN 61010-1).

**Diagrams**

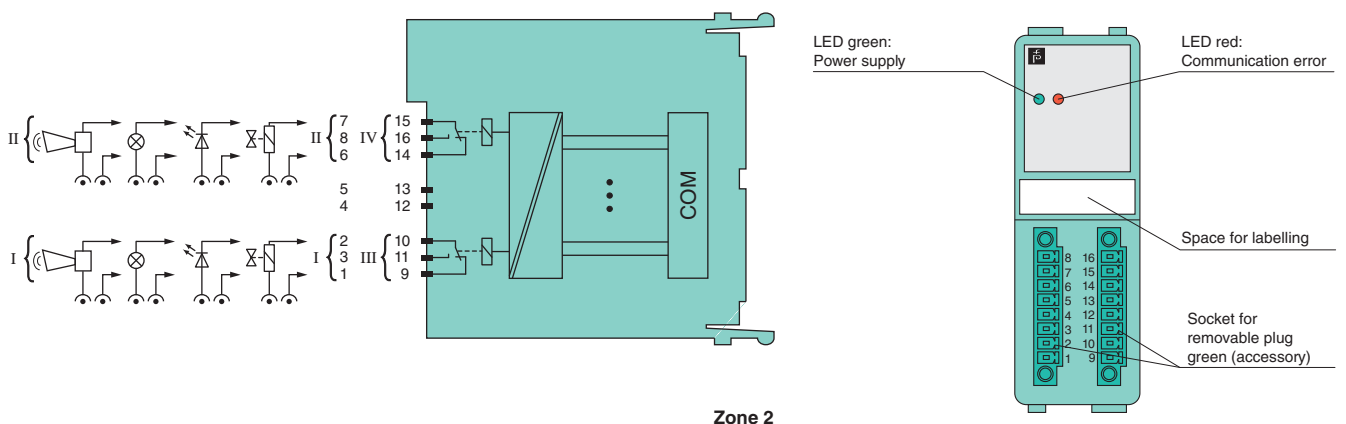

Edition 912907 (US) / 220718 (EU) 06/2011

Subject to modifications without notice

Pepperl+Fuchs Group  
www.pepperl-fuchs.com

USA: +1 330 486 0002  
pa-info@us.pepperl-fuchs.com

Germany: +49 621 776 2222  
pa-info@de.pepperl-fuchs.com

Copyright Pepperl+Fuchs  
Singapore: +65 6779 9091  
pa-info@sg.pepperl-fuchs.com





LB-System

Digital Inputs

Digital Outputs

Analog Inputs

Analog Outputs

Bus Couplers

Power Supplies

Accessories

**Features**

- 8-channel
- Contact 30 V AC/DC, 1 A, 30 W, 30 VA (resistive load)
- Device installation permissible in Zone 2 or 22 and in the safe area
- Module can be exchanged under voltage (hot swap)
- Positive or negative logic selectable
- Simulation mode for service operations (forcing)
- Permanently self-monitoring
- Output with watchdog circuit
- EMC acc. to NAMUR NE 21

**Function**

The relay output features 8 independent channels.

The relay output can be used to switch solenoids, sounders, or lamps.

It can also perform general switching operations, e.g. to switch auxiliary power circuits.

The outputs are galvanically isolated from the bus and the power supply (EN 61010-1).

**Technical data**

**Supply**

Rated voltage 12 V DC, only in connection with the power supplies LB 9\*\*\*

Power consumption 1.6 W

**Output**

Number of channels 8

Response time 20 ms (depending on bus cycle time)

Minimal switching capability  $\geq 1 \text{ V}, \geq 1 \text{ mA}$

Contact Material AgPd gold plated

Watchdog output Off 0.5 s after serious fault

Sampling time approx. 6.5 ms

**Ambient conditions**

Ambient temperature -20 ... 60 °C (-4 ... 140 °F), 70 °C (non-Ex)

**Mechanical specifications**

Mass approx. 160 g

Dimensions 32 x 100 x 103 mm (1.26 x 3.9 x 4 in)

**Data for application in connection with Ex-areas**

Supply only in connection with the power supplies LB 9\*\*\*

Declaration of conformity PF 08 CERT 1234

Group, category, type of protection, temperature classification  $\text{Ex II 3 G Ex nA nC II T4}$

**Directive conformity**

Directive 94/9/EC EN 60079-0, EN 60079-15

**International approvals**

UL approval E106378

IECEX approval BVS 09.0037X

**Diagrams**

Front view

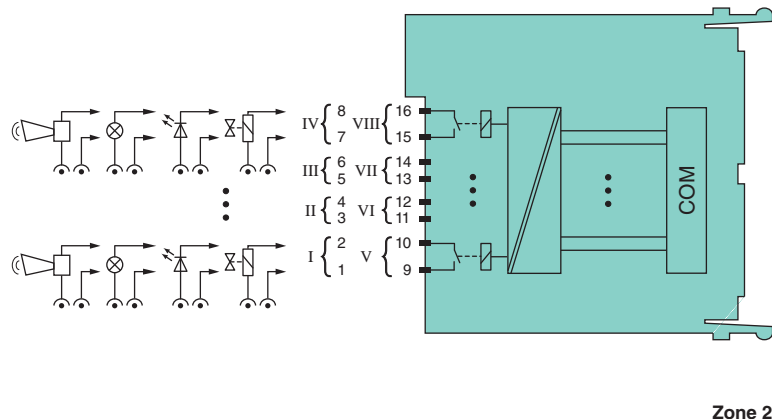
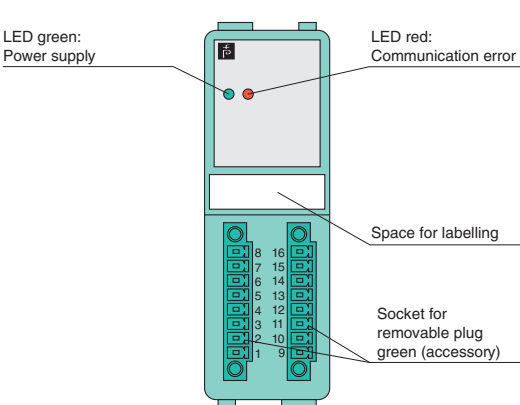

Zone 2

Edition 912907 (US) / 220718 (EU) 06/2011

| Technical data  |   |
|---|---|
| <b>Supply</b>   |   |
| Rated voltage   | 12 V DC, only in connection with the power supplies LB 9*** |
| Power consumption   | 2.2 W   |
| <b>Output</b>   |   |
| Number of channels  | 8   |
| Watchdog  | output Off 0.5 s after serious fault                        |
| Digital signals (active/short-protected)                        | 20 V, 8 mA per channel                                      |
| Sampling time   | 6.5 ms  |
| LFD test current  | 0.33 mA   |
| <b>Ambient conditions</b>                                       |   |
| Ambient temperature   | -20 ... 60 °C (-4 ... 140 °F), 70 °C (non-Ex)               |
| <b>Mechanical specifications</b>                                |   |
| Mass  | approx. 160 g   |
| Dimensions  | 32 x 100 x 103 mm (1.26 x 3.9 x 4 in)                       |
| <b>Data for application in connection with Ex-areas</b>         |   |
| Supply  | only in connection with the power supplies LB 9***          |
| Declaration of conformity                                       | PF 08 CERT 1234   |
| Group, category, type of protection, temperature classification | ⊕ II 3G Ex nA [ic] IIC T4                                   |
| Directive conformity  |   |
| Directive 94/9/EC   | EN 60079-0, EN 60079-11, EN 60079-15                        |
| <b>International approvals</b>                                  |   |
| IECEx approval  | BVS 09.0037X  |

**Features**

- 8-channel
- Galvanic group isolation
- Device installation permissible in Zone 2 or 22 and in the safe area
- Module can be exchanged under voltage (hot swap)
- Line fault detection (LFD)
- Positive or negative logic selectable
- Simulation mode for service operations (forcing)
- Permanently self-monitoring
- EMC acc. to NAMUR NE 21
- Up to SIL2 acc. to IEC 61508
- Output with watchdog circuit
- Output with bus-independent safety shutdown

**Function**

The digital output features 8 independent channels. It can drive low power solenoids, sounders, or LEDs. Line faults are detected. The outputs are galvanically isolated from the bus and the power supply (EN 60079-11). The outputs can be switched off via a contact. This can be used for bus-independent safety applications.

**Diagrams**

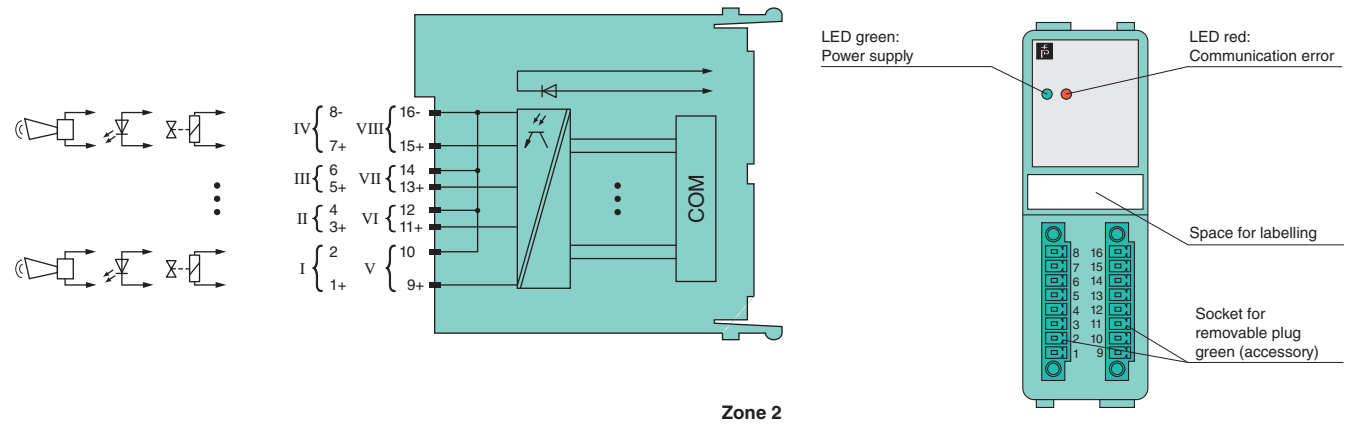

Edition 912907 (US) / 220718 (EU) 06/2011

LB-System  
 Digital Inputs  
 Digital Outputs  
 Analog Inputs  
 Analog Outputs  
 Bus Couplers  
 Power Supplies  
 Accessories



LB-System

Digital Inputs

Digital Outputs

Analog Inputs

Analog Outputs

Bus Couplers

Power Supplies

Accessories

**Features**

- 4-channel
- Outputs Ex ic
- Installation in Zone 2 and safe area
- Line fault detection (LFD)
- Positive or negative logic selectable
- Simulation mode for service operations (forcing)
- Permanently self-monitoring
- Output with watchdog circuit
- EMC acc. to NAMUR NE 21

**Function**

The digital output features 4 independent channels.

It can drive solenoids, sounders, or LEDs. Line faults are detected.

The outputs are galvanically isolated from the bus and the power supply (EN 60079-11).

**Technical data**

**Supply**

Rated voltage 12 V DC , only in connection with the power supplies LB 9\*\*\*

Power consumption 0.6 W / 5 W

**Output**

Number of channels 4

Response time 10 ms (depending on master)

Watchdog output Off 0.5 s after serious fault

Sampling time 6.5 ms

LFD test pulse every 2.5 s for 2 ms

Reaction time 10 s (worst case)

**Ambient conditions**

Ambient temperature -20 ... 60 °C (-4 ... 140 °F)

**Mechanical specifications**

Mass approx. 150 g

Dimensions 32 x 100 x 103 mm (1.26 x 3.9 x 4 in)

**Data for application in connection with Ex-areas**

Supply only in connection with the power supplies LB 9\*\*\*

Declaration of conformity PF 08 CERT 1234

Group, category, type of protection, temperature classification Ex II 3G Ex nA [ic] IIC T4

**Directive conformity**

Directive 94/9/EC EN 60079-0, IEC 60079-11, EN 60079-15

**International approvals**

IECEx approval BVS 09.0037X

**Diagrams**

Front view

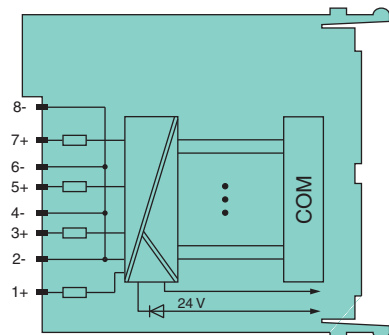
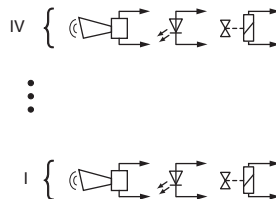
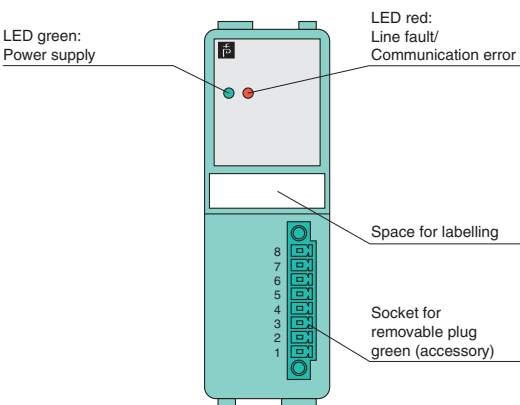

Zone 2

Edition 912907 (US) / 220718 (EU) 06/2011

| Technical data  |  |
|---|--|
| <b>Supply</b>   |  |
| Rated voltage   | 12 V DC , only in connection with the power supplies LB 9*** |
| Power consumption   | 0.6 W / 5 W  |
| <b>Output</b>   |  |
| Number of channels  | 4  |
| Response time   | 10 ms (depending on master)                                  |
| Watchdog  | output Off 0.5 s after serious fault                         |
| Sampling time   | 6.5 ms   |
| LFD test pulse  | every 2.5 s for 2 ms   |
| Reaction time   | 10 s (worst case)  |
| <b>Ambient conditions</b>                                       |  |
| Ambient temperature   | -20 ... 60 °C (-4 ... 140 °F)                                |
| <b>Mechanical specifications</b>                                |  |
| Mass  | approx. 150 g  |
| Dimensions  | 32 x 100 x 103 mm (1.26 x 3.9 x 4 in)                        |
| Data for application in connection with Ex-areas                |  |
| Supply  | only in connection with the power supplies LB 9***           |
| Declaration of conformity                                       | PF 08 CERT 1234  |
| Group, category, type of protection, temperature classification | Ⓜ II 3G Ex nA [ic] IIC T4                                    |
| <b>Directive conformity</b>                                     |  |
| Directive 94/9/EC   | EN 60079-0, IEC 60079-11, EN 60079-15                        |
| <b>International approvals</b>                                  |  |
| IECEX approval  | BVS 09.0037X   |

**Features**

- 4-channel
- Outputs Ex ic
- Installation in Zone 2 and safe area
- Line fault detection (LFD)
- Positive or negative logic selectable
- Simulation mode for service operations (forcing)
- Permanently self-monitoring
- Output with watchdog circuit
- Up to SIL2 acc. to IEC 61508
- Output with bus-independent safety shutdown
- EMC acc. to NAMUR NE 21

**Function**

The digital output features 4 independent channels. It can drive solenoids, sounders, or LEDs. Line faults are detected. The outputs are galvanically isolated from the bus and the power supply (EN 60079-11). The output can be switched off via a contact. This can be used for bus-independent safety applications.

**Diagrams**

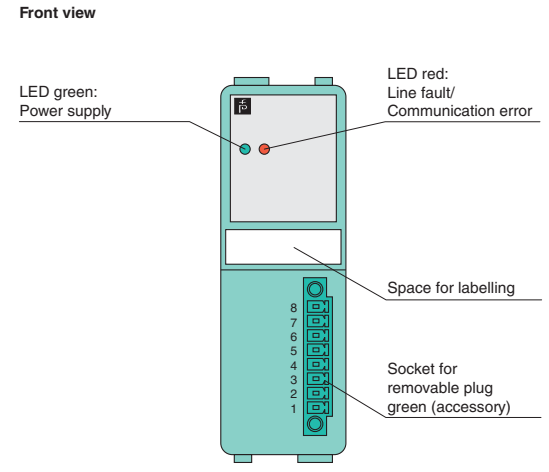
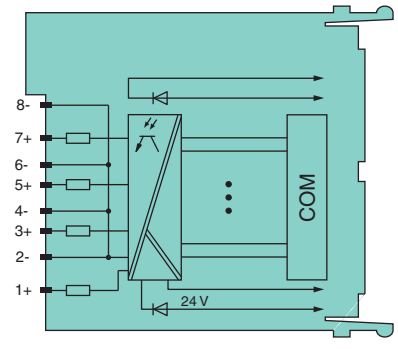
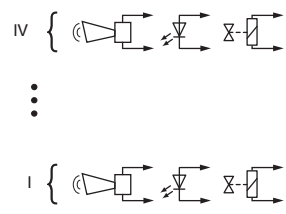

Edition 912907 (US) / 220718 (EU) 06/2011



LB-System

Digital Inputs

Digital Outputs

Analog Inputs

Analog Outputs

Bus Couplers

Power Supplies

Accessories

**Features**

- 2-channel
- Device installation permissible in Zone 2 or 22 and in the safe area
- Module can be exchanged under voltage (hot swap)
- Simulation mode for service operations (forcing)
- Permanently self-monitoring
- Output with watchdog circuit
- EMC acc. to NAMUR NE 21

**Function**

The relay output features 2 independent channels.

The relay output can be used to switch solenoids, sounders, or lamps.

It can also perform general switching operations, e.g. to switch auxiliary power circuits.

The outputs are galvanically isolated from the bus and the power supply (EN 61010-1).

**Technical data**

**Supply**

Rated voltage 12 V DC, only in connection with the power supplies LB 9\*\*\*

Power consumption 0.65 W

**Output**

Number of channels 2

Response time 20 ms (depending on bus cycle time)

Minimal switching capability  $\geq 1 \text{ V}, \geq 1 \text{ mA}$

Contact Material AgPd gold plated

Watchdog output Off 0.5 s after serious fault

**Ambient conditions**

Ambient temperature -20 ... 60 °C (-4 ... 140 °F), 70 °C (non-Ex)

**Mechanical specifications**

Mass approx. 90 g

Dimensions 16 x 100 x 103 mm (0.63 x 3.9 x 4 in)

**Data for application in connection with Ex-areas**

Supply only in connection with the power supplies LB 9\*\*\*

Declaration of conformity PF 08 CERT 1234

Group, category, type of protection, temperature classification  $\text{Ex II 3 G Ex nA nC II T4}$

Directive conformity

Directive 94/9/EC EN 60079-0, EN 60079-15

**International approvals**

UL approval pending

IECEx approval BVS 09.0037X

**Diagrams**

Front view

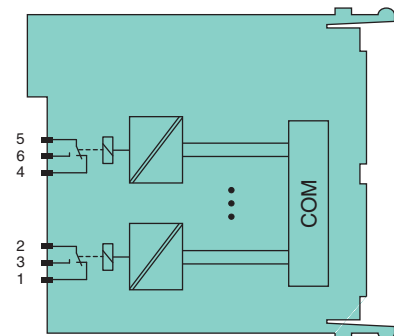
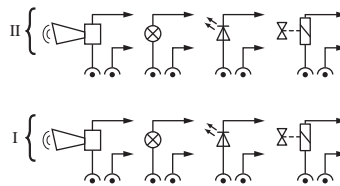
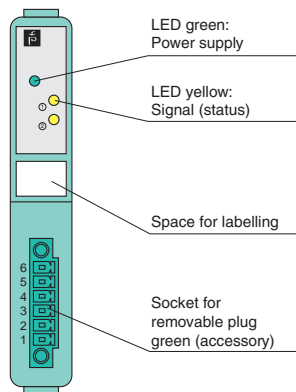

Zone 2

Edition 912907 (US) / 220718 (EU) 06/2011

| Technical data  |  |
|---|--|
| <b>Supply</b>   |  |
| Rated voltage   | 12 V DC, only in connection with the power supplies LB 9***                  |
| Power consumption   | 2.2 W  |
| <b>Output</b>   |  |
| Number of channels  | 8  |
| Watchdog  | output Off 0.5 s after serious fault   |
| Digital signals (active/short-protected)                        | 20 V, 8 mA (Type 6108A) per channel, 21.6 V, 5.2 mA (Type 6108C) per channel |
| Sampling time   | 6.5 ms   |
| LFD test current  | 0.33 mA  |
| <b>Ambient conditions</b>                                       |  |
| Ambient temperature   | -20 ... 60 °C (-4 ... 140 °F)  |
| <b>Mechanical specifications</b>                                |  |
| Mass  | approx. 160 g  |
| Dimensions  | 32 x 100 x 103 mm (1.26 x 3.9 x 4 in)  |
| <b>Data for application in connection with Ex-areas</b>         | see page 136 for entity parameters   |
| <b>EC-Type Examination Certificate</b>                          |  |
| Group, category, type of protection                             | ⊕ II (2) G [Ex ib] II C, ⊕ II (2) D [Ex ibD]                                 |
| Supply  | only in connection with the power supplies LB 9***                           |
| <b>Declaration of conformity</b>                                |  |
| Group, category, type of protection, temperature classification | ⊕ II 3 G Ex nA IIC T4  |
| <b>Directive conformity</b>                                     |  |
| Directive 94/9/EC   | EN 60079-0, EN 60079-11, EN 60079-15, EN 61241-0, EN 61241-11                |
| <b>International approvals</b>                                  |  |
| UL approval   | E106378  |
| IECEx approval  | BVS 09.0037X, BVS 08.0011X   |

**Features**

- 8-channel
- Outputs Ex ib
- Galvanic group isolation
- Installation in Zone 2 and 22 or Div. 2 and safe area
- Module can be exchanged under voltage (hot swap)
- Line fault detection (LFD)
- Positive or negative logic selectable
- Simulation mode for service operations (forcing)
- Permanently self-monitoring
- EMC acc. to NAMUR NE 21
- Up to SIL2 acc. to IEC 61508
- Output with watchdog circuit
- Output with bus-independent safety shutdown

**Function**

The digital output features 8 independent channels. It can drive low power solenoids, sounders, or LEDs. Line faults are detected. The outputs are galvanically isolated from the bus and the power supply (EN 60079-11). The outputs can be switched off via a contact. This can be used for bus-independent safety applications.

**Diagrams**

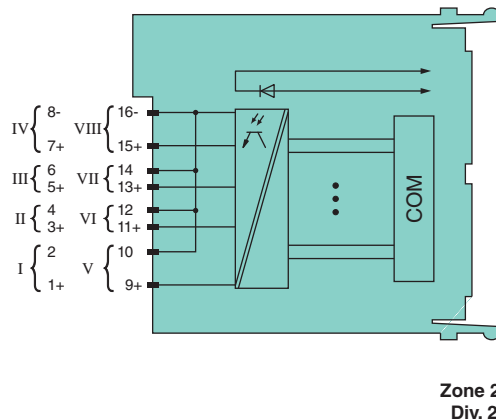
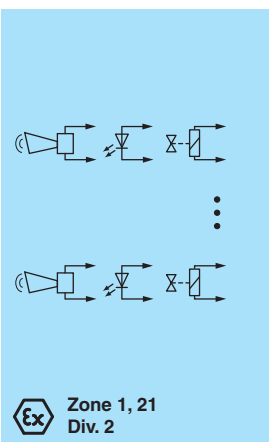

Front view

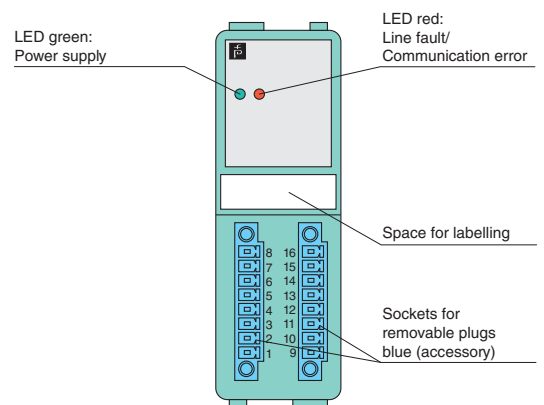

Edition 912907 (US) / 220718 (EU) 06/2011

Subject to modifications without notice

Pepperl+Fuchs Group  
www.pepperl-fuchs.com

USA: +1 330 486 0002  
pa-info@us.pepperl-fuchs.com

Germany: +49 621 776 2222  
pa-info@de.pepperl-fuchs.com

Copyright Pepperl+Fuchs  
Singapore: +65 6779 9091  
pa-info@sg.pepperl-fuchs.com



LB-System

Digital Inputs

Digital Outputs

Analog Inputs

Analog Outputs

Bus Couplers

Power Supplies

Accessories





LB-System

Digital Inputs

Digital Outputs

Analog Inputs

Analog Outputs

Bus Couplers

Power Supplies

Accessories

**Features**

- 4-channel
- Outputs Ex ia
- Installation in Zone 2 and 22 or Div. 2 and safe area
- Module can be exchanged under voltage (hot swap)
- Line fault detection (LFD)
- Positive or negative logic selectable
- Simulation mode for service operations (forcing)
- Permanently self-monitoring
- Output with watchdog circuit
- EMC acc. to NAMUR NE 21

**Function**

The digital output features 4 independent channels. It can drive solenoids, sounders, or LEDs. Line faults are detected. The outputs are galvanically isolated from the bus and the power supply (EN 60079-11).

**Technical data**

|   |  |
|---|--|
| <b>Supply</b>   |  |
| Rated voltage   | 12 V DC, only in connection with the power supplies LB 9***                |
| Power consumption   | 0.6 W/5 W  |
| <b>Output</b>   |  |
| Number of channels  | 4  |
| Response time   | 10 ms (depending on master)  |
| Watchdog  | output Off 0.5 s after serious fault                                       |
| Sampling time   | 6.5 ms   |
| LFD test pulse  | every 2.5 s for 2 ms   |
| Reaction time   | 10 s (worst case)  |
| <b>Ambient conditions</b>                                       |  |
| Ambient temperature   | -20 ... 60 °C (-4 ... 140 °F)  |
| <b>Mechanical specifications</b>                                |  |
| Mass  | approx. 150 g  |
| Dimensions  | 32 x 100 x 103 mm (1.26 x 3.9 x 4 in)                                      |
| <b>Data for application in connection with Ex-areas</b>         |  |
| EC-Type Examination Certificate                                 | PTB 03 ATEX 2042   |
| Group, category, type of protection                             | ⊕ II (1) G [Ex ia] IIC, II (1) D [Ex iaD]                                  |
| Supply  | only in connection with the power supplies LB 9***                         |
| Declaration of conformity                                       | PF 08 CERT 1234  |
| Group, category, type of protection, temperature classification | ⊕ II 3 G Ex nA IIC T4  |
| <b>Directive conformity</b>                                     |  |
| Directive 94/9/EC   | EN 60079-0, EN 60079-11, EN 60079-15, EN 60079-26, EN 61241-0, EN 61241-11 |
| <b>International approvals</b>                                  |  |
| IECEx approval  | BVS 09.0037X, BVS 08.0011X   |

**Diagrams**

Front view

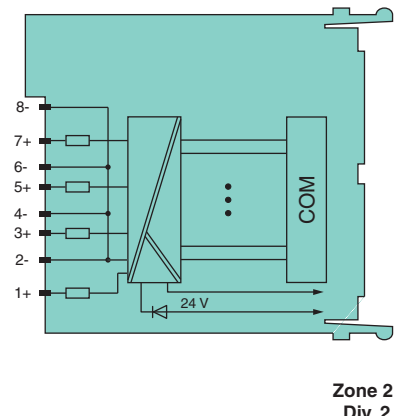
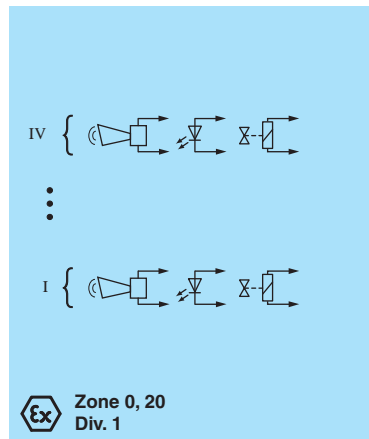
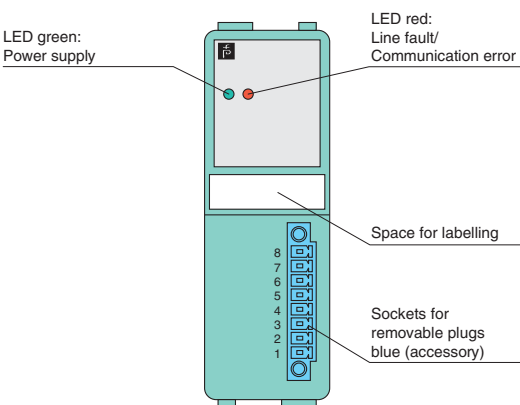

Edition 912907 (US) / 220718 (EU) 06/2011

| Technical data  |  |
|---|--|
| <b>Supply</b>   |  |
| Rated voltage   | 12 V DC, only in connection with the power supplies LB 9***                |
| Power consumption   | 0.6 W/5 W  |
| <b>Output</b>   |  |
| Number of channels  | 4  |
| Response time   | 10 ms (depending on master)  |
| Watchdog  | output Off 0.5 s after serious fault                                       |
| Sampling time   | 6.5 ms   |
| LFD test pulse  | every 2.5 s for 2 ms   |
| Reaction time   | 10 s (worst case)  |
| <b>Ambient conditions</b>                                       |  |
| Ambient temperature   | -20 ... 60 °C (-4 ... 140 °F)  |
| <b>Mechanical specifications</b>                                |  |
| Mass  | approx. 150 g  |
| Dimensions  | 32 x 100 x 103 mm (1.26 x 3.9 x 4 in)                                      |
| <b>Data for application in connection with Ex-areas</b>         |  |
| see page 136 for entity parameters                              |  |
| <b>EC-Type Examination Certificate</b>                          |  |
| Group, category, type of protection                             | PTB 03 ATEX 2042<br>⊕ II (1) G [Ex ia] IIC, II (1) D [Ex iaD]              |
| Supply  | only in connection with the power supplies LB 9***                         |
| <b>Declaration of conformity</b>                                |  |
| Group, category, type of protection, temperature classification | PF 08 CERT 1234<br>⊕ II 3 G Ex nA IIC T4                                   |
| <b>Directive conformity</b>                                     |  |
| Directive 94/9/EC   | EN 60079-0, EN 60079-11, EN 60079-15, EN 60079-26, EN 61241-0, EN 61241-11 |
| <b>International approvals</b>                                  |  |
| IECEx approval  | BVS 09.0037X, BVS 08.0011X   |

**Features**

- 4-channel
- Outputs Ex ia
- Installation in Zone 2 and 22 or Div. 2 and safe area
- Module can be exchanged under voltage (hot swap)
- Line fault detection (LFD)
- Positive or negative logic selectable
- Simulation mode for service operations (forcing)
- Permanently self-monitoring
- Output with watchdog circuit
- Up to SIL2 acc. to IEC 61508
- Output with bus-independent safety shutdown
- EMC acc. to NAMUR NE 21

**Function**

The digital output features 4 independent channels. It can drive solenoids, sounders, or LEDs. Line faults are detected. The outputs are galvanically isolated from the bus and the power supply (EN 60079-11). The output can be switched off via a contact. This can be used for bus-independent safety applications.

**Diagrams**

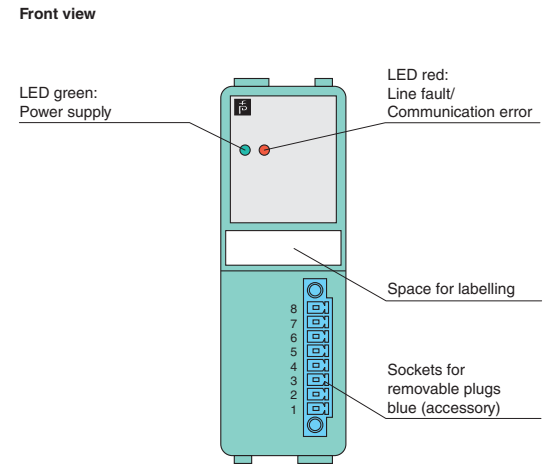
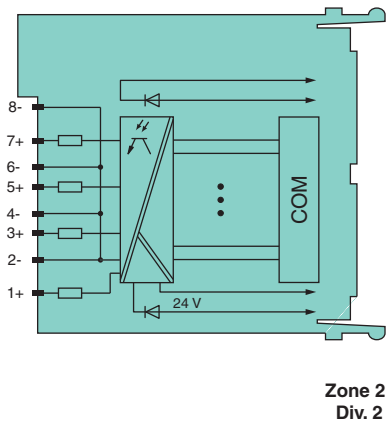
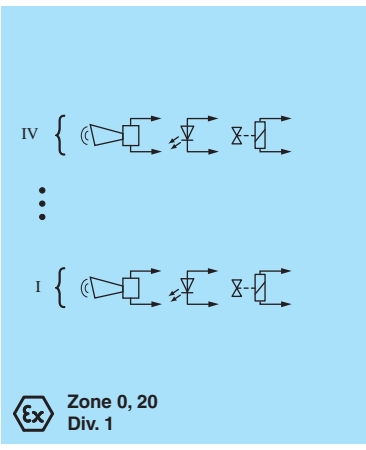

LB-System

Digital Inputs

Digital Outputs

Analog Inputs

Analog Outputs

Bus Couplers

Power Supplies

Accessories



## ATEX Entity Parameters

| Model Number | Terminals                             | $U_o$ (V) | $I_o$ (mA) | $P_o$ (mW) |
|--------------|---------------------------------------|-----------|------------|------------|
| LB 2101 *    | 1+, 4-                                | 24.9      | 91         | 558        |
|              | 2+, 5-; 3+, 6-                        | 14        | 16         | 55         |
| LB2102 A     | 1+, 4-                                | 27.8      | 183        | 1270       |
|              | 2+, 5-; 3+, 6-                        | 14        | 16         | 55         |
| LB 2103 *    | 1+, 4-                                | 27.8      | 91.5       | 636        |
|              | 2+, 5-; 3+, 6-                        | 14        | 16         | 55         |
| LB 2104 *    | 1+, 4-                                | 24.2      | 145        | 872        |
|              | 2+, 5-; 3+, 6-                        | 14        | 16         | 55         |
| LB 2105 *    | 1+, 4-                                | 25.2      | 108        | 681        |
|              | 2+, 5-; 3+, 6-                        | 14        | 16         | 55         |
| LB 2112 *    | 1+, 4-                                | 27.8      | 108        | 751        |
|              | 2+, 5-; 3+, 6-                        | 14        | 16         | 55         |
| LB 2113 *    | 1+, 4-                                | 28.7      | 68         | 485        |
|              | 2+, 5-; 3+, 6-                        | 14        | 16         | 55         |
| LB 6108 A    | 1+, 2-; 3+, 4-; 5+, 6-; 7+, 8-;       | 28        | 13.5       | 376        |
|              | 9+, 10-; 11+, 12-; 13+, 14-; 15+, 16- |           |            |            |
| LB 6108 C    | 1+, 2-; 3+, 4-; 5+, 6-; 7+, 8-;       | 30        | 13.5       | 404        |
|              | 9+, 10-; 11+, 12-; 13+, 14-; 15+, 16- |           |            |            |
| LB 6110 *    | 1+, 2-; 3+, 4-; 5+, 6-; 7+, 8-        | 27.8      | 90.4       | 629        |
| LB 6111 *    | 1+, 2-; 3+, 4-; 5+, 6-; 7+, 8-        | 27.8      | 107        | 744        |
| LB 6112 *    | 1+, 2-; 3+, 4-; 5+, 6-; 7+, 8-        | 19.8      | 142        | 705        |
| LB 6113 *    | 1+, 2-; 3+, 4-; 5+, 6-; 7+, 8-        | 26        | 110        | 714        |
| LB 6114 *    | 1+, 2-; 3+, 4-; 5+, 6-; 7+, 8-        | 26        | 88.7       | 578        |
| LB 6115 *    | 1+, 2-; 3+, 4-; 5+, 6-; 7+, 8-        | 18.9      | 286        | 1351       |

Analog Inputs – Transmitter Power Supplies

| Model Number             | Channels | Occupied Slots | Input (Field)              |                            | Supply Voltage at 20 mA | HART          |                     |                     | Input Ex ia | Input Ex ic | Mounting in Zone 2 and Zone 22 | Mounting in Div. 2 | Page |
|--------------------------|----------|----------------|----------------------------|----------------------------|-------------------------|---------------|---------------------|---------------------|-------------|-------------|--------------------------------|--------------------|------|
|                          |          |                | 2- and 3-wire Transmitters | Line Fault Detection (LFD) |                         | Communication | Secondary Variables | 4-wire Transmitters |             |             |                                |                    |      |
| LB 3002 A                | 1        | 1              | ■                          | ■                          | 16.5 V                  | ■             | ■                   | ■                   |             | ■           | ■                              |                    | 138  |
| LB 3005 A                | 4        | 2              | ■                          | ■                          | 15 V                    | ■             |                     |                     |             | ■           | ■                              |                    | 139  |
| LB 3102 A <sup>1 2</sup> | 1        | 1              | ■                          | ■                          | 16.5 V                  | ■             | ■                   | ■                   | ■           |             | ■                              | ■                  | 140  |
| LB 3105 A <sup>3</sup>   | 4        | 2              | ■                          | ■                          | 15 V                    | ■             |                     |                     | ■           |             | ■                              | ■                  | 141  |

- <sup>1</sup> LB 3102 A compatible replacement for LB 3101 A (spares available) – different IS parameters, added HART function <sup>7</sup>
- <sup>2</sup> LB 3102 A compatible replacement for LB 3103 A (spares available) – different IS parameters <sup>7</sup>
- <sup>3</sup> LB 3105 A compatible replacement for LB 3104 A (spares available) – same IS parameters, added HART function <sup>7</sup>

Analog Inputs – Temperature, Voltage Converters

| Model Number           | Channels | Occupied Slots | Input (Field)              |     |    |    |              |                            |   | Input Ex ia | Input Ex ic | Mounting in Zone 2 and Zone 22 | Mounting in Div. 2 | Page |
|------------------------|----------|----------------|----------------------------|-----|----|----|--------------|----------------------------|---|-------------|-------------|--------------------------------|--------------------|------|
|                        |          |                | 2-, 3-, and 4-wire Sensors | RTD | TC | mV | 0 V ... 10 V | Line Fault Detection (LFD) |   |             |             |                                |                    |      |
| LB 5004 A              | 4        | 2              | ■                          | ■   |    |    |              |                            | ■ |             | ■           | ■                              | 142                |      |
| LB 5005 A              | 4        | 2              |                            |     | ■  | ■  |              |                            | ■ |             | ■           | ■                              | 143                |      |
| LB 5101 A <sup>4</sup> | 1        | 1              | ■                          | ■   |    |    |              |                            | ■ |             | ■           | ■                              | 144                |      |
| LB 5102 A <sup>5</sup> | 1        | 1              |                            |     | ■  | ■  |              |                            | ■ |             | ■           | ■                              | 145                |      |
| LB 5104 A              | 4        | 2              | ■                          | ■   |    |    |              |                            | ■ |             | ■           | ■                              | 146                |      |
| LB 5105 A              | 4        | 2              |                            |     | ■  | ■  |              |                            | ■ |             | ■           | ■                              | 147                |      |
| LB 5106 A <sup>6</sup> | 1        | 1              |                            |     |    |    | ■            |                            | ■ |             | ■           | ■                              | 148                |      |

- <sup>4</sup> LB 5101 A compatible replacement for LB 5001 A (spares available) – IS version can be marked and used for non IS <sup>7</sup>
- <sup>5</sup> LB 5102 A compatible replacement for LB 5002 A (spares available) – IS version can be marked and used for non IS <sup>7</sup>
- <sup>6</sup> LB 5106 A compatible replacement for LB 5006 A (spares available) – IS version can be marked and used for non IS <sup>7</sup>
- <sup>7</sup> Replacements require configuration changes in existing installations. This can be done in a running system as it does not affect communications with the master (HCiR).

Edition 912907 (US) / 220718 (EU) 06/2011



LB-System

Digital Inputs

Digital Outputs

Analog Inputs

Analog Outputs

Bus Couplers

Power Supplies

Accessories



LB-System

Digital Inputs

Digital Outputs

Analog Inputs

Analog Outputs

Bus Couplers

Power Supplies

Accessories

**Features**

- 1-channel
- Power supply for 2- or 3-wire transmitters with 4 mA ... 20 mA
- Supply circuit 16.5 V (20 mA)
- Input from active signals of 4-wire transmitters
- Device installation permissible in Zone 2 or 22 and in the safe area
- HART communication via field bus or service bus
- HART communication also for separately powered devices
- Module can be exchanged under voltage (hot swap)
- Simulation mode for service operations (forcing)
- Line fault (LFD) and Live Zero detection
- Permanently self-monitoring
- EMC acc. to NAMUR NE 21

**Function**

The transmitter power supply feeds 2-and 3-wire transmitters.

Active signals from separately powered field devices and 4-wire transmitters can be connected.

Open and short circuit line fault alarms as well as Live Zero status are detected.

The input is galvanically isolated from the bus and the power supply (EN 60079-11).

**Technical data**

**Supply**

Rated voltage 12 V DC, only in connection with the power supplies LB 9\*\*\*

Power consumption approx. 1.2 W

**Input**

Number of channels 1

Connection terminals 2+, 5- (HART supply), terminals 5+, 6- (input), 1+, 6- (HART input)

Input resistance 15 Ω (terminals 5, 6)  
236 Ω (terminals 1-6), HART

Transmitter supply voltage min. 16 V at 20 mA  
(incl. 250 Ω HART communication resistor)

Lead monitoring Parameterization range 0 ... 26 mA  
Ex works settings: line fault < 0.5 mA;  
short circuit > 22 mA

Live Zero monitoring Ex works settings: ≤ 3.6 mA

**Transfer characteristics**

Deviation 0.1 % of the input signal range at 20 °C (68 °F)

Influence of ambient temperature 0.01 %/K of the input signal range

Resolution 12 Bit (0-26 mA)

Conversion time approx. 50 ms

**Ambient conditions**

Ambient temperature -20 ... 60 °C (-4 ... 140 °F), 70 °C (non-Ex)

**Mechanical specifications**

Mass approx. 90 g

Dimensions 16 x 100 x 103 mm (0.63 x 3.9 x 4 in)

**Data for application in connection with Ex-areas**

Supply only in connection with the power supplies LB 9\*\*\*

Declaration of conformity PF 08 CERT 1234

Group, category, type of protection, temperature classification Ⓜ II 3G Ex nA [ic] IIC T4

Directive conformity

Directive 94/9/EC EN 60079-0, EN 60079-11, EN 60079-15

**International approvals**

IECEx approval BVS 09.0037X

**Diagrams**

Front view

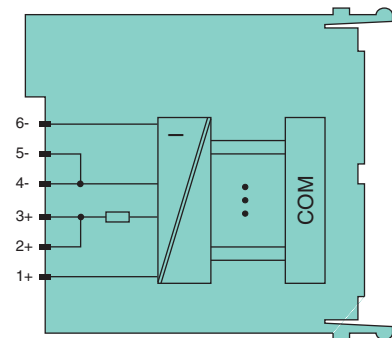
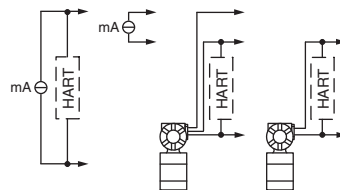
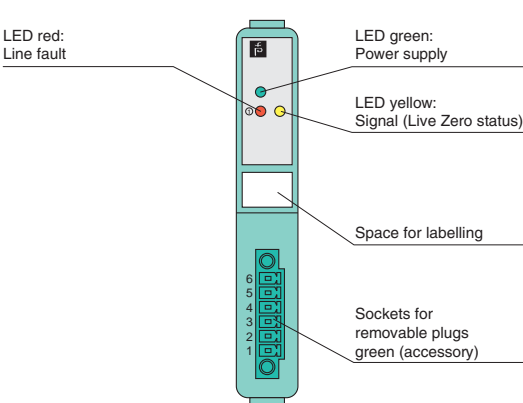

Zone 2

Edition 912907 (US) / 220718 (EU) 06/2011

| Technical data  |  |
|---|--|
| <b>Supply</b>   |  |
| Rated voltage   | 12 V DC, only in connection with the power supplies LB 9***  |
| Power consumption   | 3 W  |
| <b>Input</b>  |  |
| Number of channels  | 4  |
| Connection  | terminals 2+, 3+/4-, 5- supply, HART   |
| Input resistance  | 15 Ω (terminals 5, 6)<br>255 Ω (terminals 1-6), HART   |
| Transmitter supply voltage                                      | min. 15 V at 20 mA   |
| Lead monitoring   | Parameterization range 0 ... 26 mA<br>Ex works settings: line fault < 0.5 mA;<br>short circuit > 22 mA |
| Live Zero monitoring  | Ex works settings: ≤ 3.6 mA  |
| <b>Transfer characteristics</b>                                 |  |
| Deviation   | 0.1 % of the input signal range at 20 °C (68 °F)   |
| Influence of ambient temperature                                | 0.01 %/K of the input signal range   |
| Resolution  | 12 Bit (0-26 mA)   |
| Conversion time   | approx. 80 ms (4 channels), 130 ms during HART   |
| <b>Ambient conditions</b>                                       |  |
| Ambient temperature   | -20 ... 60 °C (-4 ... 140 °F), 70 °C (non-Ex)  |
| <b>Mechanical specifications</b>                                |  |
| Mass  | approx. 150 g  |
| Dimensions  | 32 x 100 x 103 mm (1.26 x 3.9 x 4 in)  |
| <b>Data for application in connection with Ex-areas</b>         |  |
| Supply  | only in connection with the power supplies LB 9***   |
| Declaration of conformity                                       | PF 08 CERT 1234  |
| Group, category, type of protection, temperature classification | Ⓜ II 3G Ex nA [ic] IIC T4  |
| Directive conformity  |  |
| Directive 94/9/EC   | EN 60079-0, EN 60079-11, EN 60079-15   |
| <b>International approvals</b>                                  |  |
| IECEx approval  | BVS 09.0037X   |

**Features**

- 4-channel
- Power supply for 2- or 3-wire transmitters with 4 mA ... 20 mA
- Supply circuit 15 V (20 mA)
- Input from active signals of 4-wire transmitters
- Device installation permissible in Zone 2 or 22 and in the safe area
- HART communication via field bus or service bus
- HART communication also for separately powered devices
- Module can be exchanged under voltage (hot swap)
- Simulation mode for service operations (forcing)
- Line fault (LFD) and Live Zero detection
- Permanently self-monitoring
- EMC acc. to NAMUR NE 21

**Function**

The transmitter power supply feeds 2-and 3-wire transmitters. Active signals from separately powered field devices and 4-wire transmitters can be connected. Open and short circuit line fault alarms are detected. The inputs are galvanically isolated from the bus and the power supply (EN 60079-11).

**Diagrams**

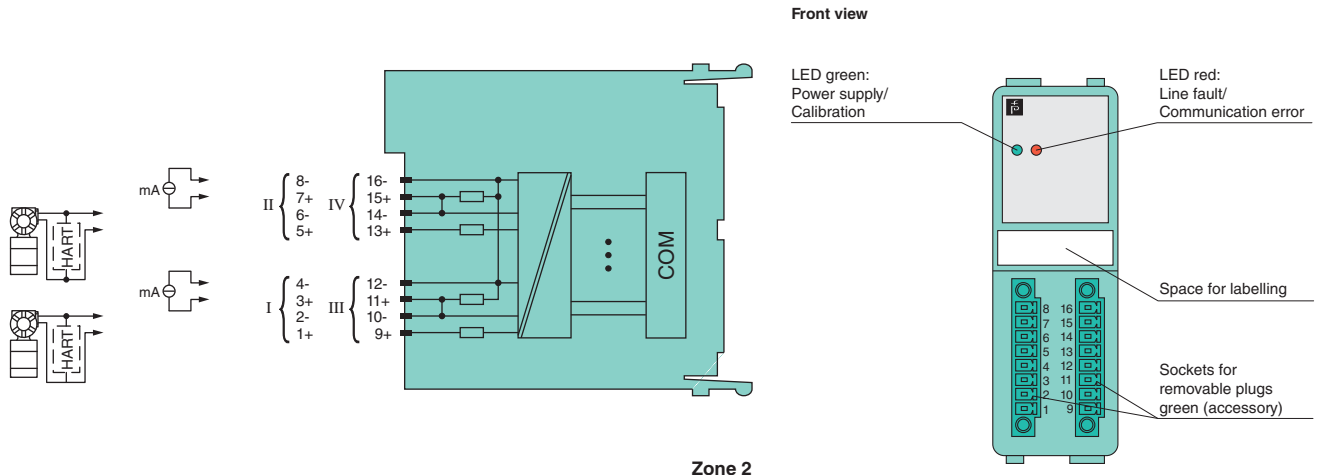

Edition 912907 (US) / 220718 (EU) 06/2011

Subject to modifications without notice

Pepperl+Fuchs Group  
www.pepperl-fuchs.com

USA: +1 330 486 0002  
pa-info@us.pepperl-fuchs.com

Germany: +49 621 776 2222  
pa-info@de.pepperl-fuchs.com

Copyright Pepperl+Fuchs  
Singapore: +65 6779 9091  
pa-info@sg.pepperl-fuchs.com



LB-System

Digital Inputs

Digital Outputs

Analog Inputs

Analog Outputs

Bus Couplers

Power Supplies

Accessories



LB-System

Digital Inputs

Digital Outputs

Analog Inputs

Analog Outputs

Bus Couplers

Power Supplies

Accessories

**Features**

- 1-channel
- Input Ex ia
- Power supply for 2- or 3-wire transmitters with 4 mA ... 20 mA
- Supply circuit 16.5 V (20 mA)
- Input from active signals of 4-wire transmitters
- Installation in Zone 2 and 22 or Div. 2 and safe area
- HART communication via field bus or service bus
- HART communication also for separately powered devices
- Module can be exchanged under voltage (hot swap)
- Simulation mode for service operations (forcing)
- Line fault (LFD) and Live Zero detection
- Permanently self-monitoring
- EMC acc. to NAMUR NE 21

**Function**

The transmitter power supply feeds 2- and 3-wire transmitters.

Active signals from separately powered field devices and 4-wire transmitters can be connected.

Open and short circuit line fault alarms as well as Live Zero status are detected.

The intrinsically safe input is galvanically isolated from the bus and the power supply (EN 60079-11).

**Technical data**

**Supply**

Rated voltage 12 V DC, only in connection with the power supplies LB 9\*\*\*

Power consumption approx. 1.2 W

**Input**

Number of channels 1

Connection terminals 2+, 5- (HART supply), terminals 5+, 6- (input), 1+, 6- (HART input)

Input resistance 15 Ω (terminals 5, 6)  
236 Ω (terminals 1, 6), HART

Transmitter supply voltage min. 16 V at 20 mA

Lead monitoring Parameterization range 0 ... 26 mA  
Ex works settings: line fault < 0.5 mA;  
short circuit > 22 mA

Live Zero monitoring Ex works settings: ≤ 3.6 mA

**Transfer characteristics**

Deviation 0.1 % of the input signal range at 20 °C (68 °F)

Influence of ambient temperature 0.01 %/K of the input signal range

Resolution 12 Bit (0-26 mA)

Conversion time approx. 50 ms

**Ambient conditions**

Ambient temperature -20 ... 60 °C (-4 ... 140 °F)

**Mechanical specifications**

Mass approx. 90 g

Dimensions 16 x 100 x 103 mm (0.63 x 3.9 x 4 in)

Data for application in connection with Ex-areas see page 149 for entity parameters

EC-Type Examination Certificate PTB 03 ATEX 2042

Group, category, type of protection Ⓜ II (1) G [Ex ia] IIC, Ⓜ II (1) D [Ex iaD]

Supply only in connection with the power supplies LB 9\*\*\*

Declaration of conformity PF 08 CERT 1234

Group, category, type of protection, temperature classification Ⓜ II 3 G Ex nA IIC T4

Directive conformity

Directive 94/9/EC EN 60079-0, EN 60079-11, EN 60079-15, EN 60079-26, EN 61241-0, EN 61241-11

**International approvals**

UL approval E106378

IECEX approval BVS 09.0037X, BVS 08.0011X

**Diagrams**

Front view

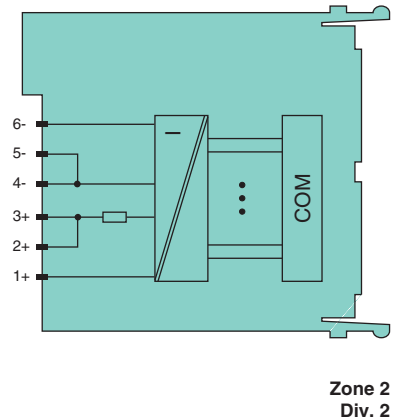
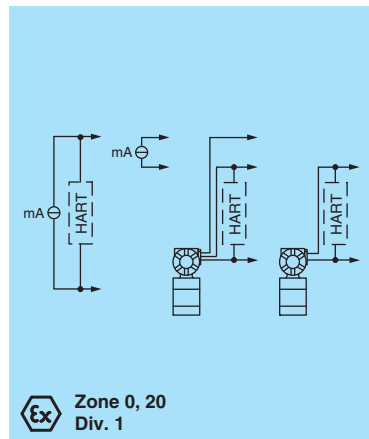
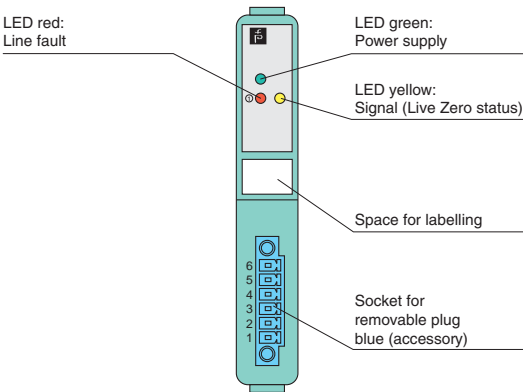

Edition 912907 (US) / 220718 (EU) 06/2011

| Technical data  |   |
|---|---|
| <b>Supply</b>   |   |
| Rated voltage   | 12 V DC, only in connection with the power supplies LB 9***   |
| Power consumption   | 3 W   |
| <b>Input</b>  |   |
| Number of channels  | 4   |
| Connection  | terminals 1+, 2-/5+, 6-/9+, 10 -/13 +, 14 - HART supply circuit<br>terminals 3+, 4-/7+, 8-/11+, 12-/15+, 16- active field devices |
| Input resistance  | 15 Ω (stat.), no HART   |
| Transmitter supply voltage                                      | min. 15 V at 20 mA  |
| Lead monitoring   | Parameterization range 0 ... 26 mA<br>Ex works settings: line fault < 0.5 mA;<br>short circuit > 22 mA                            |
| Live Zero monitoring  | Ex works settings: ≤ 3.6 mA   |
| <b>Transfer characteristics</b>                                 |   |
| Deviation   | 0.1 % of the input signal range at 20 °C (68 °F)  |
| Influence of ambient temperature                                | 0.01 %/K of the input signal range  |
| Resolution  | 12 Bit (0-26 mA)  |
| Conversion time   | approx. 80 ms (4 channels)<br>130 ms during HART  |
| <b>Ambient conditions</b>                                       |   |
| Ambient temperature   | -20 ... 60 °C (-4 ... 140 °F)   |
| <b>Mechanical specifications</b>                                |   |
| Mass  | approx. 150 g   |
| Dimensions  | 32 x 100 x 103 mm (1.26 x 3.9 x 4 in)   |
| <b>Data for application in connection with Ex-areas</b>         | see page 149 for entity parameters  |
| EC-Type Examination Certificate                                 | PTB 03 ATEX 2042  |
| Group, category, type of protection                             | ⊕ II (1) G [Ex ia] IIC, ⊕ II (1) D [Ex iaD]   |
| Supply  | only in connection with the power supplies LB 9***  |
| Declaration of conformity                                       | PF 08 CERT 1234   |
| Group, category, type of protection, temperature classification | ⊕ II 3 G Ex nA IIC T4   |
| Directive conformity  |   |
| Directive 94/9/EC   | EN 60079-0, EN 60079-11, EN 60079-15,<br>EN 60079-26, EN 61241-0, EN 61241-11   |
| <b>International approvals</b>                                  |   |
| UL approval   | E106378   |
| IECEx approval  | BVS 09.0037X, BVS 08.0011X  |

**Features**

- 4-channel
- Inputs Ex ia
- Power supply for 2- or 3-wire transmitters with 4 mA ... 20 mA
- Supply circuit 15 V (20 mA)
- Input from active signals of 4-wire transmitters
- Installation in Zone 2 and 22 or Div. 2 and safe area
- HART communication via field bus or service bus
- Module can be exchanged under voltage (hot swap)
- Simulation mode for service operations (forcing)
- Line fault detection (LFD)
- Permanently self-monitoring
- EMC acc. to NAMUR NE 21

**Function**

The transmitter power supply feeds 2- and 3-wire transmitters. Active signals from separately powered field devices and 4-wire transmitters can be connected. Open and short circuit line fault alarms as well as Live Zero status are detected. The intrinsically safe inputs are galvanically isolated from the bus and the power supply (EN 60079-11).

**Diagrams**

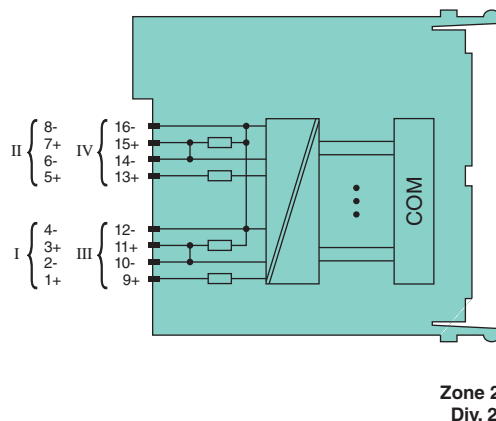
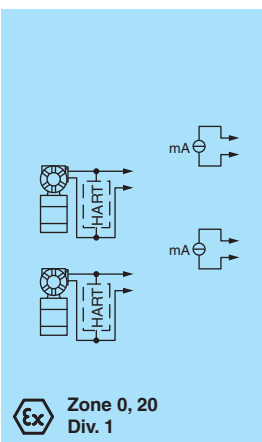

Front view

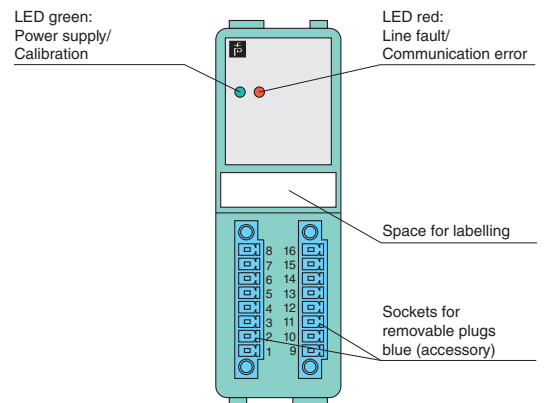

Edition 912907 (US) / 220718 (EU) 06/2011

Subject to modifications without notice

Pepperl+Fuchs Group  
www.pepperl-fuchs.com

USA: +1 330 486 0002  
pa-info@us.pepperl-fuchs.com

Germany: +49 621 776 2222  
pa-info@de.pepperl-fuchs.com

Copyright Pepperl+Fuchs  
Singapore: +65 6779 9091  
pa-info@sg.pepperl-fuchs.com



LB-System

Digital Inputs

Digital Outputs

Analog Inputs

Analog Outputs

Bus Couplers

Power Supplies

Accessories



LB-System

Digital Inputs

Digital Outputs

Analog Inputs

Analog Outputs

Bus Couplers

Power Supplies

Accessories

**Features**

- 4-channel
- Converter for 2-, 3- and 4-wire RTDs (Pt100 ... Pt1000), slide wire sensors etc.
- Device installation permissible in Zone 2 or 22 and in the safe area
- Module can be exchanged under voltage (hot swap)
- Simulation mode for service operations (forcing)
- Line fault detection (LFD)
- Permanently self-monitoring
- EMC acc. to NAMUR NE 21

**Function**

The temperature converter accepts 2, 3, 4-wire RTD (Pt100 ... Pt1000) signals and slide wire sensors from the field. Ni100 through Ni1000 can also be connected. Open or short circuit line fault alarms are detected. The inputs are galvanically isolated from the bus and the power supply ( EN 60079-11).

**Technical data**

|   |   |
|---|---|
| <b>Supply</b>   |   |
| Rated voltage   | 12 V DC, only in connection with the power supplies LB 9***   |
| Power consumption   | 0.6 W   |
| <b>Input</b>  |   |
| Number of channels  | 4   |
| Connection  | terminals 1-4, 5-8, 9-12, 13-16   |
| Lead resistance   | ≤ 50 Ω per strand   |
| Pt 100 range (-200 ... 850 °C)                                  | 18 ... 390 Ω (500 Ω incl. line resistance)  |
| Measurement range   | Pt200 (37-780 Ω), Pt 500 (92-1952 Ω), Pt 1000 (185-3905 Ω), Ni100 (69-270 Ω), Ni500 (345-1350 Ω), Ni1000 (690-2700 Ω) |
| Slide-wire sensor   | 0 ... 10000 Ω   |
| Measuring current   | 200 µA  |
| Line fault detection (Pt 100)                                   | ≥ 1 kΩ (open circuit), ≤ 10 Ω (short circuit)   |
| Smallest span   | 50 Ω (or 1/10 of the measuring range)   |
| Linearity error   | max. 0.1 %  |
| Temperature influence   | max. 0.1 %/10 K   |
| Conversion time   | ≤ 500 ms (4 channels)<br>≤ 1 s (for 4x 3-wire Pt100)  |
| Busy after download   | 5 ... 15 s  |
| <b>Ambient conditions</b>                                       |   |
| Ambient temperature   | -20 ... 60 °C (-4 ... 140 °F), 70 °C (non-Ex)   |
| <b>Mechanical specifications</b>                                |   |
| Mass  | approx. 150 g   |
| Dimensions  | 32 x 100 x 103 mm (1.26 x 3.9 x 4 in)   |
| <b>Data for application in connection with Ex-areas</b>         |   |
| Supply  | only in connection with the power supplies LB 9***  |
| Declaration of conformity                                       | PF 08 CERT 1234   |
| Group, category, type of protection, temperature classification | ⊕ II 3G Ex nA [ic] IIC T4   |
| Directive conformity  |   |
| Directive 94/9/EC   | EN 60079-0, EN 60079-11, EN 60079-15  |
| <b>International approvals</b>                                  |   |
| IECEX approval  | BVS 09.0037X  |

**Diagrams**

Front view

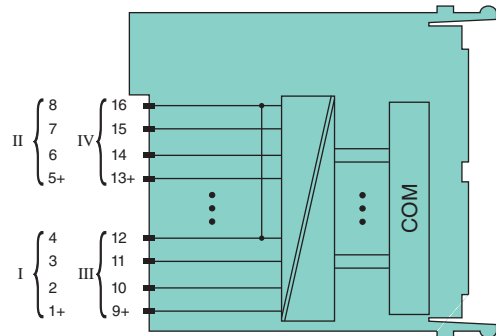
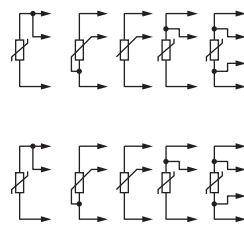
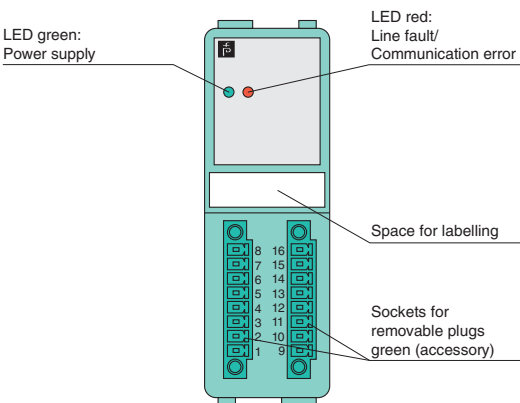

Zone 2

Edition 912907 (US) / 220718 (EU) 06/2011

| Technical data  |  |
|---|--|
| <b>Supply</b>   |  |
| Rated voltage   | 12 V DC, only in connection with the power supplies LB 9***        |
| Power consumption   | 1 W  |
| <b>Input</b>  |  |
| Number of channels  | 4  |
| Connection  | terminals 1, 2, 5, 6, 9, 10, 13, 14                                |
| Measurement range   | -65 ... 75 mV with LFD, -75 ... 75 mV without LFD                  |
| Smallest span   | 5 mV (for 0.1 %)   |
| Linearity error   | max. 0.1 %   |
| Temperature influence   | max. 0.1 %/10 K  |
| Conversion time   | ≤ 200 ms (4 channels) without LFD<br>≤ 350 ms (4-channel) with LFD |
| Compensation (reference junction CJC)                           | internal (built-in) or external (e. g. thermostat)                 |
| Line fault detection (LFD)                                      | ≥ 1 kΩ   |
| Test voltage  | 1.5 kV input - input<br>1.5 kV input - bus and auxiliary power     |
| <b>Ambient conditions</b>                                       |  |
| Ambient temperature   | -20 ... 60 °C (-4 ... 140 °F), 70 °C (non-Ex)                      |
| <b>Mechanical specifications</b>                                |  |
| Mass  | approx. 150 g  |
| Dimensions  | 32 x 100 x 103 mm (1.26 x 3.9 x 4 in)                              |
| <b>Data for application in connection with Ex-areas</b>         |  |
| Supply  | only in connection with the power supplies LB 9***                 |
| Declaration of conformity                                       | PF 08 CERT 1234  |
| Group, category, type of protection, temperature classification | Ⓜ II 3G Ex nA [ic] IIC T4  |
| <b>Directive conformity</b>                                     |  |
| Directive 94/9/EC   | EN 60079-0, EN 60079-11, EN 60079-15                               |
| <b>International approvals</b>                                  |  |
| IECEx approval  | BVS 09.0037X   |

**Features**

- 4-channel
- Converter for thermocouples and mV-signals
- Device installation permissible in Zone 2 or 22 and in the safe area
- Module can be exchanged under voltage (hot swap)
- Simulation mode for service operations (forcing)
- Line fault detection (LFD)
- Permanently self-monitoring
- EMC acc. to NAMUR NE 21

**Function**

The thermocouple converter accepts thermocouple or mV signals from the field.

Open circuit line fault alarms are detected.

The inputs are galvanically isolated from the bus and the power supply (EN 60079-11). There is a functional isolation between the channels.

**Diagrams**

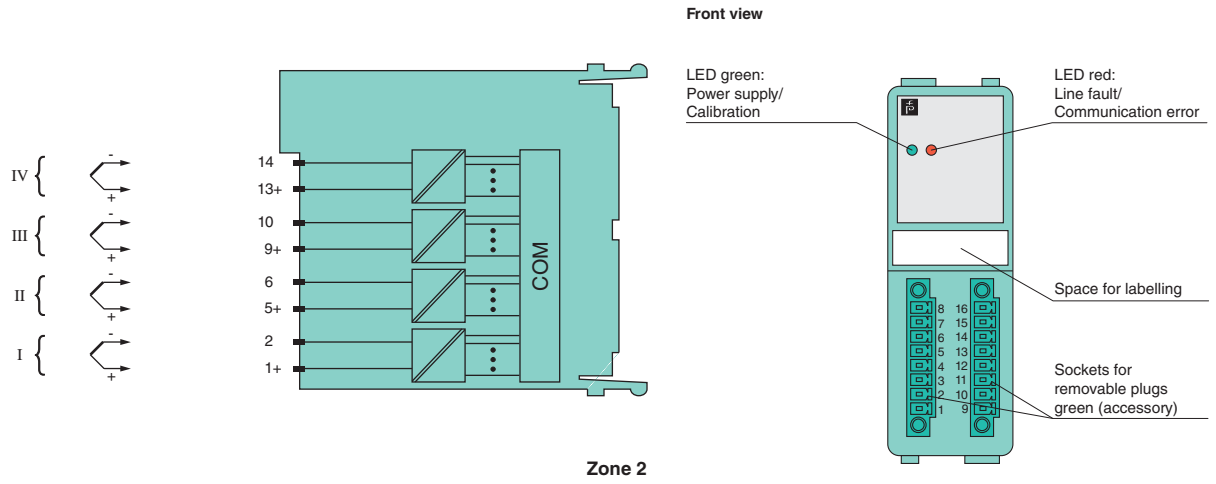

LB-System  
 Digital Inputs  
 Digital Outputs  
 Analog Inputs  
 Analog Outputs  
 Bus Couplers  
 Power Supplies  
 Accessories

Edition 912907 (US) / 220718 (EU) 06/2011





LB-System

Digital Inputs

Digital Outputs

Analog Inputs

Analog Outputs

Bus Couplers

Power Supplies

Accessories

**Features**

- 1-channel
- Input Ex ia
- Converter for 2-, 3- and 4-wire Pt100, slide wire sensors
- Installation in Zone 2 and 22 or Div. 2 and safe area
- Module can be exchanged under voltage (hot swap)
- Simulation mode for service operations (forcing)
- Line fault detection (LFD)
- Permanently self-monitoring
- EMC acc. to NAMUR NE 21

**Function**

The temperature converter accepts 2, 3, 4-wire RTD (Pt100) signals from the hazardous area.

Open or short circuit line fault alarms are detected.

The intrinsically safe input is galvanically isolated from the bus and the power supply (EN 60079-11).

**Technical data**

**Supply**

Rated voltage 12 V DC, only in connection with the power supplies LB 9\*\*\*

Power consumption 0.45 W

**Input**

Number of channels 1

Connection terminals 1, 2, 5, 6

Line fault detection option: On/Off, see connection diagram  
switching point:  
- short circuit: < 10 Ω  
- open circuit: > 1 kΩ

Lead resistance ≤ 50 Ω per strand

Measurement range 10 ... 400 Ω (500 Ω incl. line resistance)

Measuring current 200 μA

Smallest span 20 Ω for 0.1 % accuracy

Linearity error 0.1 %

Temperature influence 0.1 %/10 K

Conversion time ≤ 20 ms without LFD  
≤ 150 ms with LFD

**Ambient conditions**

Ambient temperature -20 ... 60 °C (-4 ... 140 °F)

**Mechanical specifications**

Mass approx. 90 g

Dimensions 16 x 100 x 103 mm (0.63 x 3.9 x 4 in)

**Data for application in connection with Ex-areas** see page 149 for entity parameters

EC-Type Examination Certificate PTB 03 ATEX 2042

Group, category, type of protection Ⓜ II (1) G [Ex ia] IIC, II (1) D [Ex iaD]

Supply only in connection with the power supplies LB 9\*\*\*

Declaration of conformity PF 08 CERT 1234

Group, category, type of protection, temperature classification Ⓜ II 3 G Ex nA IIC T4

**Directive conformity**

Directive 94/9/EC EN 60079-0, EN 60079-11, EN 60079-15, EN 60079-26, EN 61241-0, EN 61241-11

**International approvals**

UL approval E106378

IECEx approval BVS 09.0037X, BVS 08.0011X

**Diagrams**

Front view

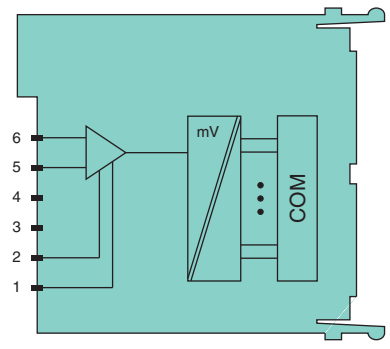
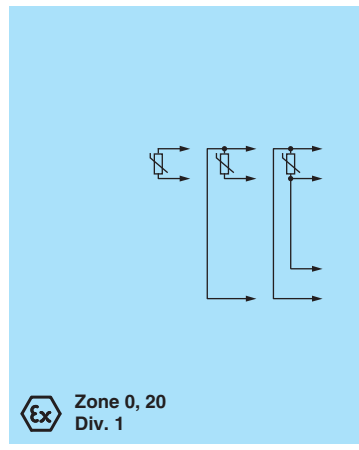
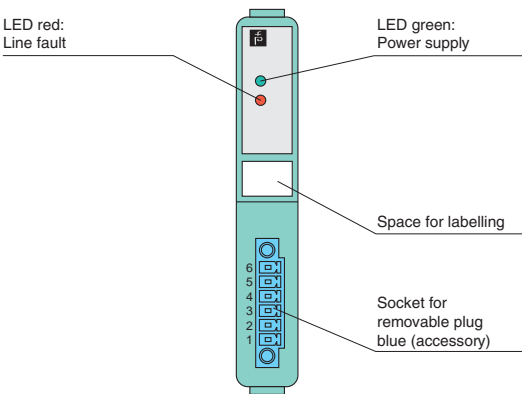

Zone 2 Div. 2

Edition 912907 (US) / 220718 (EU) 06/2011

| Technical data  |   |
|---|---|
| <b>Supply</b>   |   |
| Rated voltage   | 12 V DC, only in connection with the power supplies LB 9***                           |
| Power consumption   | 0.45 W  |
| <b>Input</b>  |   |
| Number of channels  | 1   |
| Connection  | terminals 1, 2 (cold junction RTD), 5+, 6- (TC)                                       |
| Line fault detection  | option: On/Off, see connection diagram<br>switching points:<br>- open circuit: > 1 kΩ |
| Measurement range   | U, B, E, T, K, S, R, L, J, N, Pallaplat<br>-75 ... 75 mV                              |
| Linearity error   | 0.1 %   |
| Temperature influence   | 0.1 %/10 K  |
| Conversion time with external reference junction                | ≤ 20 ms without LFD<br>≤ 80 ms with LFD   |
| Conversion time with internal reference junction                | ≤ 120 ms without LFD<br>≤ 240 ms with LFD   |
| Compensation (reference junction CJC)                           | internal or external (e. g. thermostat)   |
| Sensor current for Pt 100 CJC                                   | 200 μA  |
| Line fault detection (LFD)                                      | ≥ 1 kΩ  |
| <b>Ambient conditions</b>                                       |   |
| Ambient temperature   | -20 ... 60 °C (-4 ... 140 °F)   |
| <b>Mechanical specifications</b>                                |   |
| Mass  | approx. 90 g  |
| Dimensions  | 16 x 100 x 103 mm (0.63 x 3.9 x 4 in)   |
| <b>Data for application in connection with Ex-areas</b>         | see page 149 for entity parameters  |
| EC-Type Examination Certificate                                 | PTB 03 ATEX 2042  |
| Group, category, type of protection                             | ⊕ II (1) G [Ex ia] IIC, II (1) D [Ex iaD]   |
| Supply  | only in connection with the power supplies LB 9***                                    |
| Declaration of conformity                                       | PF 08 CERT 1234   |
| Group, category, type of protection, temperature classification | ⊕ II 3 G Ex nA IIC T4   |
| Directive conformity  |   |
| Directive 94/9/EC   | EN 60079-0, EN 60079-11, EN 60079-15, EN 60079-26, EN 61241-0, EN 61241-11            |
| <b>International approvals</b>                                  |   |
| UL approval   | E106378   |
| IECEx approval  | BVS 09.0037X, BVS 08.0011X  |

Features

- 1-channel
- Input Ex ia
- Converter for thermocouples and mV-signals
- Installation in Zone 2 and 22 or Div. 2 and safe area
- Module can be exchanged under voltage (hot swap)
- Simulation mode for service operations (forcing)
- Line fault detection (LFD)
- Permanently self-monitoring
- EMC acc. to NAMUR NE 21

Function

The mV input accepts thermocouple or mV signals from the hazardous area. Open circuit line fault alarms are detected. The intrinsically safe input is galvanically isolated from the bus and the power supply (EN 60079-11).

Diagrams

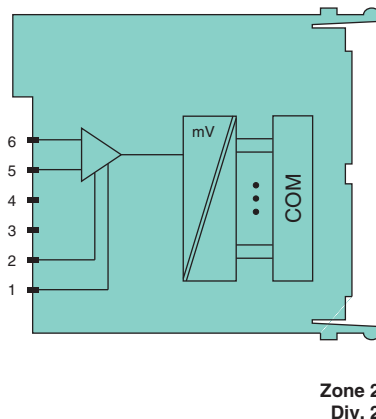
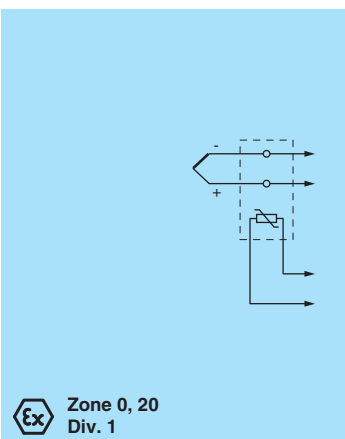

Front view

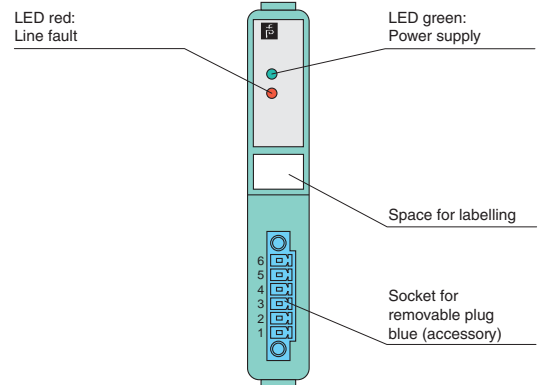

Edition 912907 (US) / 220718 (EU) 06/2011

Subject to modifications without notice

Pepperl+Fuchs Group  
www.pepperl-fuchs.com

USA: +1 330 486 0002  
pa-info@us.pepperl-fuchs.com

Germany: +49 621 776 2222  
pa-info@de.pepperl-fuchs.com

Copyright Pepperl+Fuchs  
Singapore: +65 6779 9091  
pa-info@sg.pepperl-fuchs.com



LB-System

Digital Inputs

Digital Outputs

Analog Inputs

Analog Outputs

Bus Couplers

Power Supplies

Accessories

LB-System  
Digital Inputs  
Digital Outputs  
Analog Inputs  
Analog Outputs  
Bus Couplers  
Power Supplies  
Accessories

Features

- 4-channel
- Inputs Ex ia
- Converter for 2-, 3- and 4-wire RTDs (Pt100 ... Pt1000), slide wire sensors etc.
- Installation in Zone 2 and 22 or Div. 2 and safe area
- Module can be exchanged under voltage (hot swap)
- Simulation mode for service operations (forcing)
- Line fault detection (LFD)
- Permanently self-monitoring
- EMC acc. to NAMUR NE 21

Function

The temperature converter accepts 2, 3, 4-wire RTD (Pt100 ... Pt1000) signals and slide wire sensors from the hazardous area. Ni100 through Ni1000 can also be connected.

Open or short circuit line fault alarms are detected.

The intrinsically safe inputs are galvanically isolated from the bus and the power supply ( EN 60079-11).

Technical data

|   |   |
|---|---|
| <b>Supply</b>   |   |
| Rated voltage   | 12 V DC, only in connection with the power supplies LB 9***   |
| Power consumption   | 0.6 W   |
| <b>Input</b>  |   |
| Number of channels  | 4   |
| Connection  | terminals 1-4, 5-8, 9-12, 13-16   |
| Lead resistance   | ≤ 50 Ω per strand   |
| Pt 100 range (-200 ... 850 °C)                                  | 18 ... 390 Ω (500 Ω incl. line resistance)  |
| Measurement range   | Pt200 (37-780 Ω), Pt 500 (92-1952 Ω), Pt 1000 (185-3905 Ω), Ni100 (69-270 Ω), Ni500 (345-1350 Ω), Ni1000 (690-2700 Ω) |
| Slide-wire sensor   | 0 ... 10000 Ω   |
| Measuring current   | 200 µA  |
| Line fault detection (Pt 100)                                   | ≥ 1 kΩ (open circuit), ≤ 10 Ω (short circuit)   |
| Smallest span   | 50 Ω (or 1/10 of the measuring range)   |
| Linearity error   | 0.1 %   |
| Temperature influence   | 0.1 %/10 K  |
| Conversion time   | ≤ 500 ms (4 channels)<br>≤ 1 s (for 4x 3-wire Pt100)  |
| Busy after download   | 5 ... 15 s  |
| <b>Ambient conditions</b>                                       |   |
| Ambient temperature   | -20 ... 60 °C (-4 ... 140 °F)   |
| <b>Mechanical specifications</b>                                |   |
| Mass  | approx. 150 g   |
| Dimensions  | 32 x 100 x 103 mm (1.26 x 3.9 x 4 in)   |
| <b>Data for application in connection with Ex-areas</b>         |   |
| EC-Type Examination Certificate                                 | PTB 03 ATEX 2042  |
| Group, category, type of protection                             | ⊕ II (1) G [Ex ia] IIC, II (1) D [Ex iaD]   |
| Supply  | only in connection with the power supplies LB 9***  |
| Declaration of conformity                                       | PF 08 CERT 1234   |
| Group, category, type of protection, temperature classification | ⊕ II 3 G Ex nA IIC T4   |
| Directive conformity  |   |
| Directive 94/9/EC   | EN 60079-0, EN 60079-11, EN 60079-15, EN 60079-26, EN 61241-0, EN 61241-11  |
| <b>International approvals</b>                                  |   |
| UL approval   | E106378   |
| IECEX approval  | BVS 09.0037X, BVS 08.0011X  |

Diagrams

Front view

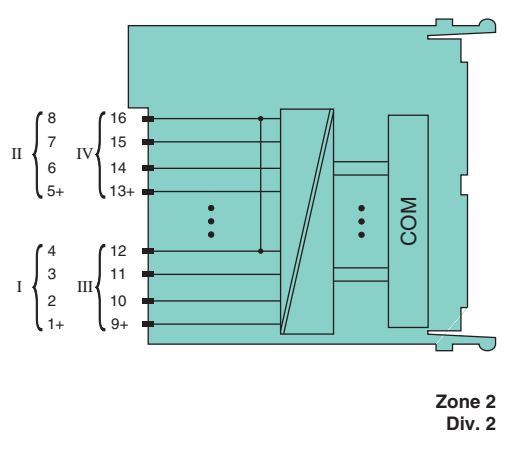
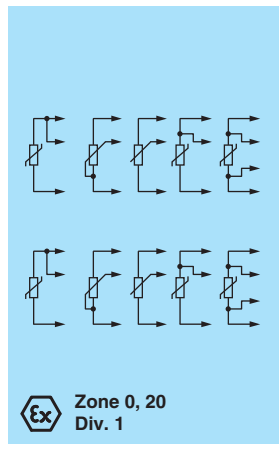
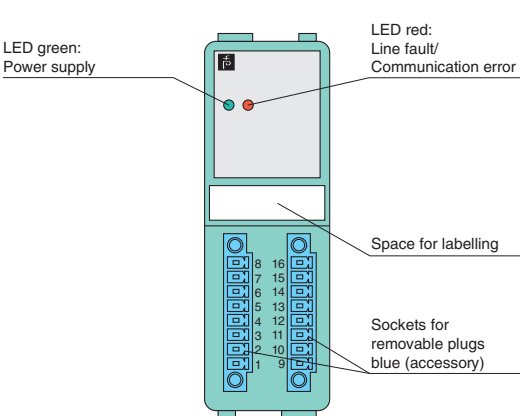

Edition 912907 (US) / 220718 (EU) 06/2011

| Technical data  |  |
|---|--|
| <b>Supply</b>   |  |
| Rated voltage   | 12 V DC, only in connection with the power supplies LB 9***                |
| Power consumption   | 1 W  |
| <b>Input</b>  |  |
| Number of channels  | 4  |
| Connection  | terminals 1, 2, 5, 6, 9, 10, 13, 14  |
| Measurement range   | -65 ... 75 mV with LFD, -75 ... 75 mV without LFD                          |
| Smallest span   | 5 mV (for 0.1 %)   |
| Linearity error   | 0.1 %  |
| Temperature influence   | 0.1 %/10 K   |
| Conversion time   | ≤ 300 ms (4 channels) without LFD<br>≤ 600 ms (4-channel) with LFD         |
| Compensation (reference junction CJC)                           | internal (built-in) or external (e. g. thermostat)                         |
| Line fault detection (LFD)                                      | ≥ 1 kΩ   |
| Test voltage  | 1.5 kV input - input<br>1.5 kV input - bus and auxiliary power             |
| <b>Ambient conditions</b>                                       |  |
| Ambient temperature   | -20 ... 60 °C (-4 ... 140 °F)  |
| <b>Mechanical specifications</b>                                |  |
| Mass  | approx. 150 g  |
| Dimensions  | 32 x 100 x 103 mm (1.26 x 3.9 x 4 in)                                      |
| <b>Data for application in connection with Ex-areas</b>         |  |
| EC-Type Examination Certificate                                 | PTB 03 ATEX 2042   |
| Group, category, type of protection                             | ⊕ II (1) G [Ex ia] IIC, II (1) D [Ex iaD]                                  |
| Supply  | only in connection with the power supplies LB 9***                         |
| Declaration of conformity                                       | PF 08 CERT 1234  |
| Group, category, type of protection, temperature classification | ⊕ II 3 G Ex nA IIC T4  |
| <b>Directive conformity</b>                                     |  |
| Directive 94/9/EC   | EN 60079-0, EN 60079-11, EN 60079-15, EN 60079-26, EN 61241-0, EN 61241-11 |
| <b>International approvals</b>                                  |  |
| UL approval   | E106378  |
| IECEx approval  | BVS 09.0037X, BVS 08.0011X   |

Features

- 4-channel
- Inputs Ex ia
- Converter for thermocouples and mV-signals
- Installation in Zone 2 and 22 or Div. 2 and safe area
- Module can be exchanged under voltage (hot swap)
- Simulation mode for service operations (forcing)
- Line fault detection (LFD)
- Permanently self-monitoring
- EMC acc. to NAMUR NE 21

Function

The thermocouple converter accepts thermocouple or mV signals from hazardous area. Open circuit line fault alarms are detected. The intrinsically safe inputs are galvanically isolated from the bus and the power supply (EN 60079-11). There is a functional isolation between the channels.

Diagrams

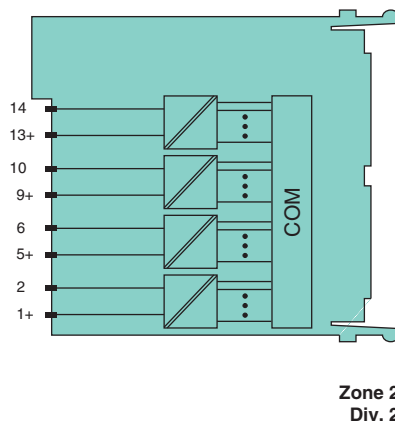
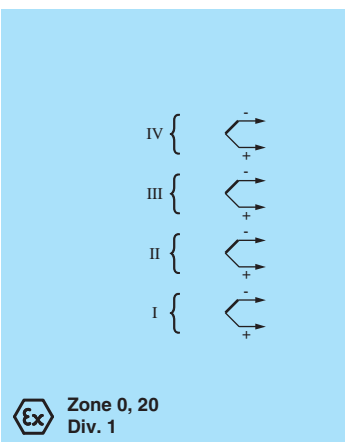

Front view

LED green: Power supply/ Calibration

LED red: Line fault/ Communication error

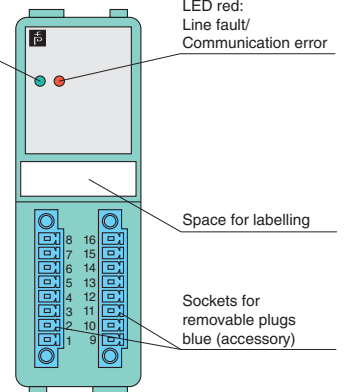

Edition 912907 (US) / 220718 (EU) 06/2011

Subject to modifications without notice

Pepperl+Fuchs Group  
www.pepperl-fuchs.com

USA: +1 330 486 0002  
pa-info@us.pepperl-fuchs.com

Germany: +49 621 776 2222  
pa-info@de.pepperl-fuchs.com

Copyright Pepperl+Fuchs  
Singapore: +65 6779 9091  
pa-info@sg.pepperl-fuchs.com



LB-System

Digital Inputs

Digital Outputs

Analog Inputs

Analog Outputs

Bus Couplers

Power Supplies

Accessories



LB-System

Digital Inputs

Digital Outputs

Analog Inputs

Analog Outputs

Bus Couplers

Power Supplies

Accessories

**Features**

- 1-channel
- Input Ex ia
- Input 0 V ... 10 V
- Installation in Zone 2 and 22 or Div. 2 and safe area
- Module can be exchanged under voltage (hot swap)
- Simulation mode for service operations (forcing)
- Permanently self-monitoring
- EMC acc. to NAMUR NE 21

**Function**

The voltage converter accepts signals from the hazardous area. The intrinsically safe input is galvanically isolated from the bus and the power supply (EN 60079-11).

**Technical data**

**Supply**

Rated voltage 12 V DC, only in connection with the power supplies LB 9\*\*\*

Power consumption 0.45 W

**Input**

Number of channels 1

Connection terminals 5+, 6-

Input resistance 100 kΩ

Measurement range 0 ... 10 V

Smallest span 500 mV

Linearity error 0.1 %

Temperature influence 0.1 %/10 K

Conversion time ≤ 100 ms

**Ambient conditions**

Ambient temperature -20 ... 60 °C (-4 ... 140 °F)

**Mechanical specifications**

Mass approx. 90 g

Dimensions 16 x 100 x 103 mm (0.63 x 3.9 x 4 in)

**Data for application in connection with Ex-areas** see page 149 for entity parameters

EC-Type Examination Certificate PTB 03 ATEX 2042

Group, category, type of protection Ⓜ II (1) G [Ex ia] IIC, II (1) D [Ex iaD]

Supply only in connection with the power supplies LB 9\*\*\*

Declaration of conformity PF 08 CERT 1234

Group, category, type of protection, temperature classification Ⓜ II 3 G Ex nA IIC T4

**Directive conformity**

Directive 94/9/EC EN 60079-0, EN 60079-11, EN 60079-15, EN 60079-26, EN 61241-0, EN 61241-11

**International approvals**

UL approval E106378

IECEX approval BVS 09.0037X, BVS 08.0011X

**Diagrams**

Front view

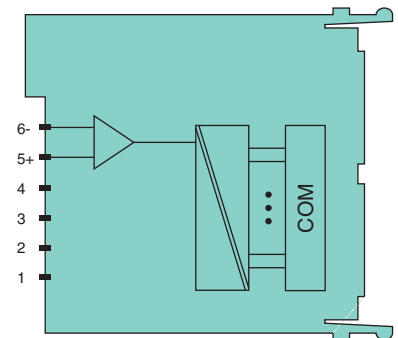
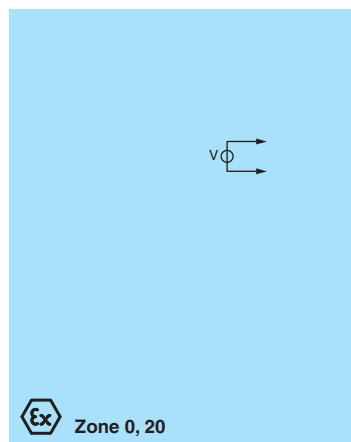
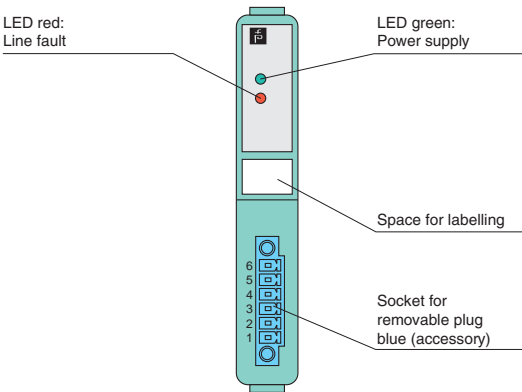

Zone 2 Div. 2

Edition 912907 (US) / 220718 (EU) 06/2011

## ATEX Entity Parameters

| Model Number | Terminals  | $U_o$ (V)  | $I_o$ (mA) | $P_o$ (mW) |
|--------------|--|------------|------------|------------|
| LB 3102 A    | 4/5+, 6<br>1+, 6-  | 0.7<br>8.9 | 3<br>56    | 2<br>336   |
| LB 3105 A    | 3+, 4-; 7+, 8-; 11+, 12-; 15+, 16-                       | 0.7        | 2.3        | 2          |
| LB 5101 A    | 5, 6; 5, 1, 6; 1, 2, 5, 6                                | 2.7        | 43         | 93         |
| LB 5102 A    | 1+, 2-, 5+, 6-   | 1.8        | 43         | 67         |
| LB 5104 A    | 1, 2, 3, 4; 5, 6, 7, 8;<br>9, 10, 11, 12; 13, 14, 15, 16 | 7.14       | 70         | 123        |
| LB 5105 A    | 1+, 2-; 5+, 6-; 9+, 10-; 13+, 14-                        | 1.0        | 71         | 62         |
| LB 5106 A    | 5+, 6-   | 0.9        | 0.2        | 0.2        |



LB-System

Digital  
InputsDigital  
OutputsAnalog  
InputsAnalog  
OutputsBus  
CouplersPower  
Supplies

Accessories



## Analog Outputs

| Model Number             | Channels | Occupied Slots | Output (Field)   |                   |                            |                 |                    | SIL | Output Ex ia | Output Ex ic | Mounting in Zone 2 and Zone 22 | Mounting in Div. 2 | Page |
|--------------------------|----------|----------------|------------------|-------------------|----------------------------|-----------------|--------------------|-----|--------------|--------------|--------------------------------|--------------------|------|
|                          |          |                | 0/4 mA ... 20 mA | Watchdog Function | Line Fault Detection (LFD) | Simulation Mode | HART Communication |     |              |              |                                |                    |      |
| LB 4002 A                | 1        | 1              | ■                | ■                 | ■                          | ■               | ■                  |     |              | ■            | ■                              |                    | 152  |
| LB 4005 D <sup>1</sup>   | 4        | 2              | ■                | ■                 | ■                          | ■               | ■                  |     |              | ■            | ■                              |                    | 153  |
| LB 4102 A <sup>2</sup>   | 1        | 1              | ■                | ■                 | ■                          | ■               | ■                  |     | ■            |              | ■                              | ■                  | 154  |
| LB 4102 C                | 1        | 1              | ■                | ■                 | ■                          | ■               | ■                  | 2   | ■            |              | ■                              | ■                  | 155  |
| LB 4105 C                | 4        | 2              | ■                | ■                 | ■                          | ■               | ■                  | 2   | ■            |              | ■                              | ■                  | 156  |
| LB 4105 D <sup>3 4</sup> | 4        | 2              | ■                | ■                 | ■                          | ■               | ■                  |     | ■            |              | ■                              | ■                  | 157  |

<sup>1</sup> LB 4005 D compatible replacement for LB 4005 A (spares available) – new gateways allow LFD to be switched off

<sup>2</sup> LB 4102 A compatible replacement for LB 4101 A (spares available) – same IS parameters, added HART function <sup>5</sup>

<sup>3</sup> LB 4105 D compatible replacement for LB 4104 A (spares available) – same IS parameters, added HART function <sup>5</sup>

<sup>4</sup> LB 4105 D compatible replacement for LB 4105 A (spares available) – new gateways allow LFD to be switched off

<sup>5</sup> Replacements require configuration changes in existing installations. This can be done in a running system as it does not affect communications with the master (HCiR).



LB-System

Digital Inputs

Digital Outputs

Analog Inputs

Analog Outputs

Bus Couplers

Power Supplies

Accessories





LB-System

Digital Inputs

Digital Outputs

Analog Inputs

Analog Outputs

Bus Couplers

Power Supplies

Accessories

**Features**

- 1-channel
- Analog output module for 0/4 mA ... 20 mA
- Device installation permissible in Zone 2 or 22 and in the safe area
- HART communication via field bus or service bus
- Module can be exchanged under voltage (hot swap)
- Simulation mode for service operations (forcing)
- Line fault detection (LFD)
- Permanently self-monitoring
- EMC acc. to NAMUR NE 21

**Function**

The analog output drives positioners, proportional valves, I/P converters, or local indicators.

Open circuit line fault alarms are detected.

The output is galvanically isolated from the bus and the power supply (EN 60079-11).

**Technical data**

**Supply**

Rated voltage 12 V DC, only in connection with the power supplies LB 9\*\*\*

Power consumption 0.8 W

**Output**

Number of channels 1

Connection terminals 2+, 3+/4-, 5-

Current 4 ... 20 mA (0 ... 25 mA) short circuit protected

Load 750 Ω max.

Line fault detection min. 1 mA

Response threshold ≥ 850 Ω

Watchdog output Off 0.5 s after serious fault

**Transfer characteristics**

Deviation 0.1 % of the input signal range at 20 °C (68 °F)

Influence of ambient temperature 0.01 %/K of the input signal range

Conversion time approx. 50 ms

**Ambient conditions**

Ambient temperature -20 ... 60 °C (-4 ... 140 °F), 70 °C (non-Ex)

**Mechanical specifications**

Mass approx. 90 g

Dimensions 16 x 100 x 103 mm (0.63 x 3.9 x 4 in)

**Data for application in connection with Ex-areas**

Supply only in connection with the power supplies LB 9\*\*\*

Declaration of conformity PF 08 CERT 1234

Group, category, type of protection, temperature classification Ex II 3G Ex nA [ic] IIC T4

Directive conformity

Directive 94/9/EC EN 60079-0, EN 60079-11, EN 60079-15

**International approvals**

IECEx approval BVS 09.0037X

**Diagrams**

Front view

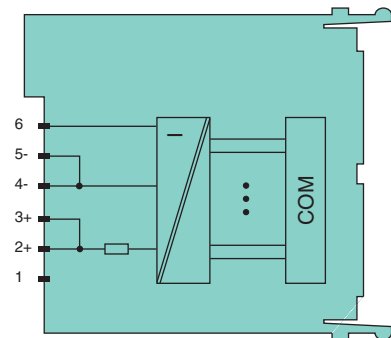
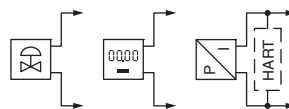
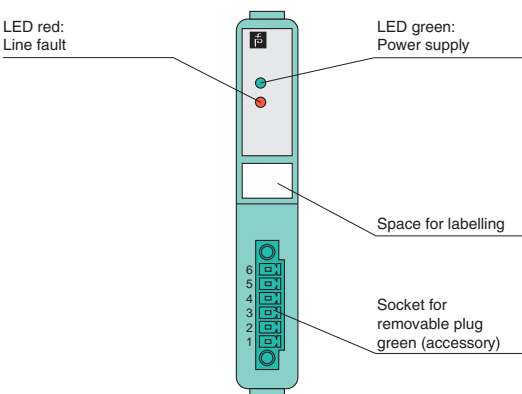

Zone 2

Edition 912907 (US) / 220718 (EU) 06/2011

| Technical data  |   |
|---|---|
| <b>Supply</b>   |   |
| Rated voltage   | 12 V DC, only in connection with the power supplies LB 9*** |
| Power consumption   | 3 W   |
| <b>Output</b>   |   |
| Number of channels  | 4   |
| Connection  | terminals 1+, 2-, 3+, 4-, 5+, 6-, 7+, 8-                    |
| Current   | 4 ... 20 mA (0 ... 25 mA)<br>short circuit protected        |
| Load  | 750 Ω max.  |
| Line fault detection  | min. 1 mA (depending on model)                              |
| Response threshold  | ≥ 850 Ω   |
| Watchdog  | output Off 0.5 s after serious fault                        |
| <b>Transfer characteristics</b>                                 |   |
| Deviation   | 0.1 % of the input signal range at 20 °C (68 °F)            |
| Influence of ambient temperature                                | 0.01 %/K of the input signal range                          |
| Conversion time   | approx. 58 ms, 110 ms during HART                           |
| <b>Ambient conditions</b>                                       |   |
| Ambient temperature   | -20 ... 60 °C (-4 ... 140 °F), 70 °C (non-Ex)               |
| <b>Mechanical specifications</b>                                |   |
| Mass  | approx. 150 g   |
| Dimensions  | 32 x 100 x 103 mm (1.26 x 3.9 x 4 in)                       |
| <b>Data for application in connection with Ex-areas</b>         |   |
| Supply  | only in connection with the power supplies LB 9***          |
| Declaration of conformity                                       | PF 08 CERT 1234   |
| Group, category, type of protection, temperature classification | ⊕ II 3G Ex nA [ic] IIC T4                                   |
| Directive conformity  |   |
| Directive 94/9/EC   | EN 60079-0, EN 60079-11, EN 60079-15                        |
| <b>International approvals</b>                                  |   |
| IECEX approval  | BVS 09.0037X  |

- Features**
- 4-channel
  - Analog output module for 0/4 mA ... 20 mA
  - Device installation permissible in Zone 2 or 22 and in the safe area
  - HART communication via field bus or service bus
  - Module can be exchanged under voltage (hot swap)
  - Simulation mode for service operations (forcing)
  - Line fault detection (LFD) depending on model
  - Permanently self-monitoring
  - EMC acc. to NAMUR NE 21

**Function**

The analog output drives positioners, proportional valves, I/P converters, or local indicators.

Open circuit line fault alarms are detected, depending on the parameter setting.

The output is galvanically isolated from the bus and the power supply (EN 60079-11).

**Diagrams**

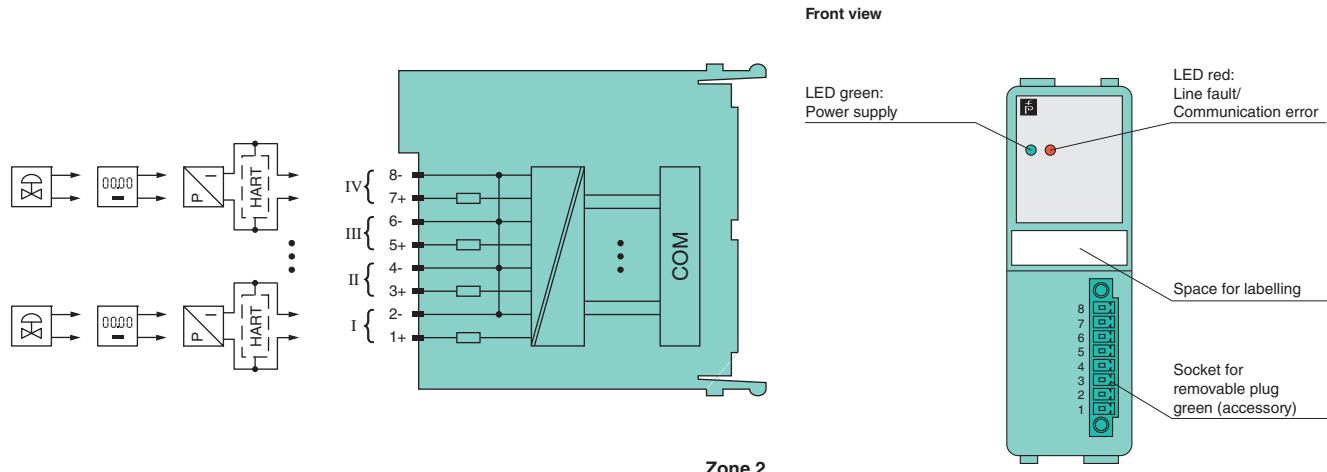

Edition 912907 (US) / 220718 (EU) 06/2011

Subject to modifications without notice

Pepperl+Fuchs Group  
www.pepperl-fuchs.com

USA: +1 330 486 0002  
pa-info@us.pepperl-fuchs.com

Germany: +49 621 776 2222  
pa-info@de.pepperl-fuchs.com

Copyright Pepperl+Fuchs  
Singapore: +65 6779 9091  
pa-info@sg.pepperl-fuchs.com

LB-System  
Digital Inputs  
Digital Outputs  
Analog Inputs  
Analog Outputs  
Bus Couplers  
Power Supplies  
Accessories



LB-System

Digital Inputs

Digital Outputs

Analog Inputs

Analog Outputs

Bus Couplers

Power Supplies

Accessories

**Features**

- 1-channel
- Output Ex ia
- Analog output module for 0/4 mA ... 20 mA
- Installation in Zone 2 and 22 or Div. 2 and safe area
- HART communication via field bus or service bus
- Module can be exchanged under voltage (hot swap)
- Simulation mode for service operations (forcing)
- Line fault detection (LFD)
- Permanently self-monitoring
- EMC acc. to NAMUR NE 21

**Function**

The analog output drives positioners, proportional valves, I/P converters, or local indicators.

Open circuit line fault alarms are detected.

The output is galvanically isolated from the bus and the power supply (EN 60079-11).

**Technical data**

**Supply**

Rated voltage 12 V DC, only in connection with the power supplies LB 9\*\*\*

Power consumption 0.73 W

**Output**

Number of channels 1

Connection terminals 2+, 3+/-, 5-

Current 4 ... 20 mA (0 ... 25 mA) short circuit protected

Load ≤ 750 Ω

Line fault detection min. 1 mA

Response threshold ≥ 850 Ω

Watchdog output Off 0.5 s after serious fault

**Transfer characteristics**

Deviation 0.1 % of the input signal range at 20 °C (68 °F)

Influence of ambient temperature 0.01 %/K of the input signal range

Conversion time approx. 50 ms

**Ambient conditions**

Ambient temperature -20 ... 60 °C (-4 ... 140 °F)

**Mechanical specifications**

Mass approx. 90 g

Dimensions 16 x 100 x 103 mm (0.63 x 3.9 x 4 in)

Data for application in connection with Ex-areas see page 158 for entity parameters

EC-Type Examination Certificate PTB 03 ATEX 2042

Group, category, type of protection Ⓜ II (1) G [Ex ia] IIC, Ⓜ II (1) D [Ex iaD]

Supply only in connection with the power supplies LB 9\*\*\*

Declaration of conformity PF 08 CERT 1234

Group, category, type of protection, temperature classification Ⓜ II 3 G Ex nA IIC T4

Directive conformity

Directive 94/9/EC EN 60079-0, EN 60079-11, EN 60079-15, EN 60079-26, EN 61241-0, EN 61241-11

**International approvals**

UL approval E106378

IECEX approval BVS 09.0037X, BVS 08.0011X

**Diagrams**

Front view

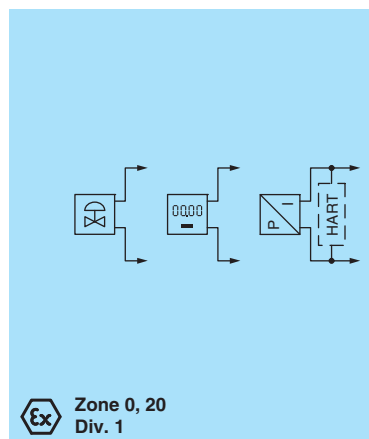
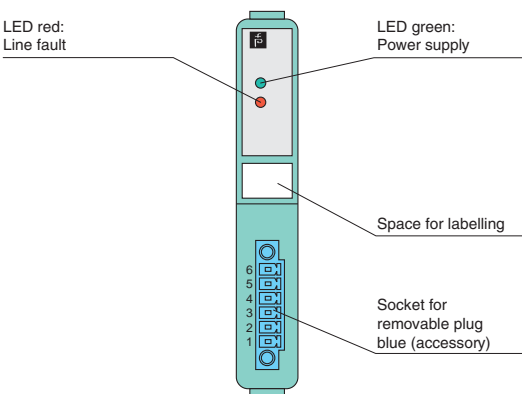

Zone 0, 20 Div. 1

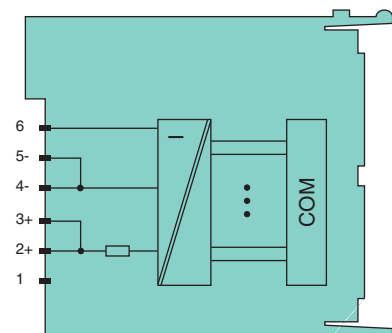

Zone 2 Div. 2

Edition 912907 (US) / 220718 (EU) 06/2011

| Technical data  |  |
|---|--|
| <b>Supply</b>   |  |
| Rated voltage   | 12 V DC, only in connection with the power supplies LB 9***                |
| Power consumption   | 0.73 W   |
| <b>Output</b>   |  |
| Number of channels  | 1  |
| Connection  | terminals 2+, 3+/4-, 5-  |
| Current   | 4 ... 20 mA (0 ... 25 mA)<br>short-circuit protected                       |
| Load  | ≤ 750 Ω  |
| Line fault detection  | min. 1 mA  |
| Response threshold  | ≥ 850 Ω  |
| Watchdog  | output Off 0.5 s after serious fault                                       |
| <b>Transfer characteristics</b>                                 |  |
| Deviation   | 0.1 % of the input signal range at 20 °C (68 °F)                           |
| Influence of ambient temperature                                | 0.01 %/K of the input signal range   |
| Conversion time   | approx. 50 ms  |
| <b>Ambient conditions</b>                                       |  |
| Ambient temperature   | -20 ... 60 °C (-4 ... 140 °F)  |
| <b>Mechanical specifications</b>                                |  |
| Mass  | approx. 90 g   |
| Dimensions  | 16 x 100 x 103 mm (0.63 x 3.9 x 4 in)                                      |
| <b>Data for application in connection with Ex-areas</b>         | see page 158 for entity parameters   |
| EC-Type Examination Certificate                                 | PTB 03 ATEX 2042   |
| Group, category, type of protection                             | ⊕ II (1) G [Ex ia] IIC, ⊕ II (1) D [Ex iaD]                                |
| Supply  | only in connection with the power supplies LB 9***                         |
| Declaration of conformity                                       | PF 08 CERT 1234  |
| Group, category, type of protection, temperature classification | ⊕ II 3 G Ex nA IIC T4  |
| Directive conformity  |  |
| Directive 94/9/EC   | EN 60079-0, EN 60079-11, EN 60079-15, EN 60079-26, EN 61241-0, EN 61241-11 |
| <b>International approvals</b>                                  |  |
| UL approval   | E106378  |
| IECEx approval  | BVS 09.0037X, BVS 08.0011X   |

**Features**

- 1-channel
- Output Ex ia
- Analog output module for 0/4 mA ... 20 mA
- Installation in Zone 2 and 22 or Div. 2 and safe area
- HART communication via field bus or service bus
- Module can be exchanged under voltage (hot swap)
- Simulation mode for service operations (forcing)
- Line fault detection (LFD)
- Permanently self-monitoring
- EMC acc. to NAMUR NE 21
- Up to SIL2 acc. to IEC 61508

**Function**

The analog output drives positioners, proportional valves, I/P converters, or local indicators.

The output can be switched off via a contact. This can be used for bus-independent safety applications.

The output is galvanically isolated from the bus and the power supply (EN 60079-11).

**Diagrams**

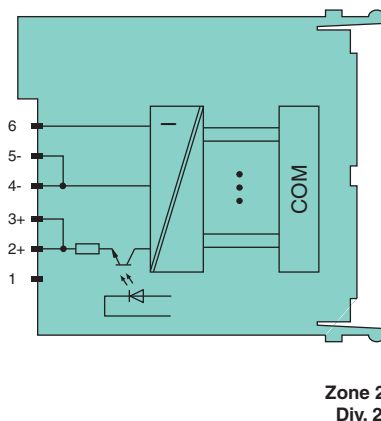
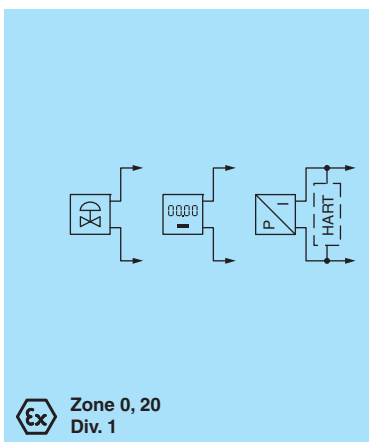

Front view

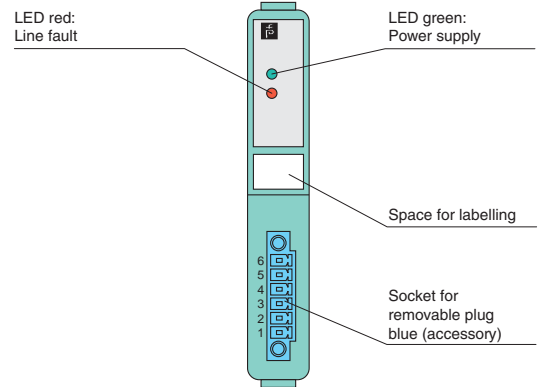

Edition 912907 (US) / 220718 (EU) 06/2011

Subject to modifications without notice

Pepperl+Fuchs Group  
www.pepperl-fuchs.com

USA: +1 330 486 0002  
pa-info@us.pepperl-fuchs.com

Germany: +49 621 776 2222  
pa-info@de.pepperl-fuchs.com

Copyright Pepperl+Fuchs  
Singapore: +65 6779 9091  
pa-info@sg.pepperl-fuchs.com



LB-System

Digital Inputs

Digital Outputs

Analog Inputs

Analog Outputs

Bus Couplers

Power Supplies

Accessories





LB-System

Digital Inputs

Digital Outputs

Analog Inputs

Analog Outputs

Bus Couplers

Power Supplies

Accessories



**Features**

- 4-channel
- Outputs Ex ia
- Analog output module for 0/4 mA ... 20 mA
- Installation in Zone 2 and 22 or Div. 2 and safe area
- HART communication via field bus or service bus
- Module can be exchanged under voltage (hot swap)
- Simulation mode for service operations (forcing)
- Line fault detection (LFD)
- Permanently self-monitoring
- EMC acc. to NAMUR NE 21
- Up to SIL2 acc. to IEC 61508

**Function**

The analog output drives positioners, proportional valves, I/P converters, or local indicators.

Open circuit line fault alarms are detected.

The outputs can be switched off via a contact. This can be used for bus-independent safety applications.

The outputs are galvanically isolated from the bus and the power supply (EN 60079-11).

**Technical data**

**Supply**

Rated voltage 12 V DC, only in connection with the power supplies LB 9\*\*\*

Power consumption 3 W

**Output**

Number of channels 4

Connection terminals 1+, 2-, 3+, 4-, 5+, 6-, 7+, 8-

Current 4 ... 20 mA (0 ... 25 mA) short circuit protected

Load 750 Ω max.

Line fault detection min. 1 mA

Response threshold ≥ 850 Ω

Watchdog output OFF 0.5 s after serious fault

**Transfer characteristics**

Deviation 0.1 % of the input signal range at 20 °C (68 °F)

Influence of ambient temperature 0.01 %/K of the input signal range

Conversion time 58 ms (4 channels)

110 ms during HART

**Ambient conditions**

Ambient temperature -20 ... 60 °C (-4 ... 140 °F)

**Mechanical specifications**

Mass approx. 150 g

Dimensions 32 x 100 x 103 mm (1.26 x 3.9 x 4 in)

Data for application in connection with Ex-areas see page 158 for entity parameters

EC-Type Examination Certificate PTB 03 ATEX 2042

Group, category, type of protection Ex II (1) G [Ex ia] IIC, Ex II (1) D [Ex iaD]

Supply only in connection with the power supplies LB 9\*\*\*

Declaration of conformity PF 08 CERT 1234

Group, category, type of protection, temperature classification Ex II 3 G Ex nA IIC T4

Directive conformity

Directive 94/9/EC EN 60079-0, EN 60079-11, EN 60079-15, EN 60079-26, EN 61241-0, EN 61241-11

**International approvals**

UL approval E106378

IECEx approval BVS 09.0037X, BVS 08.0011X

**Diagrams**

Front view

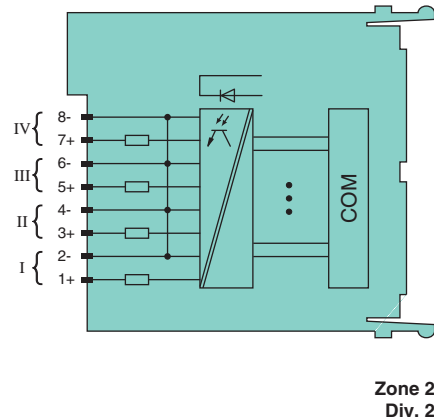
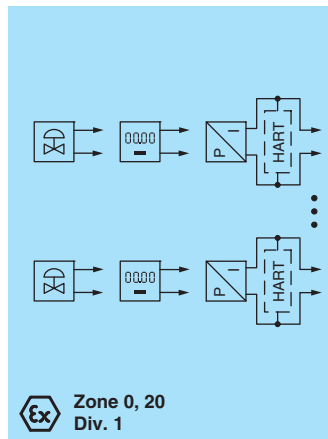
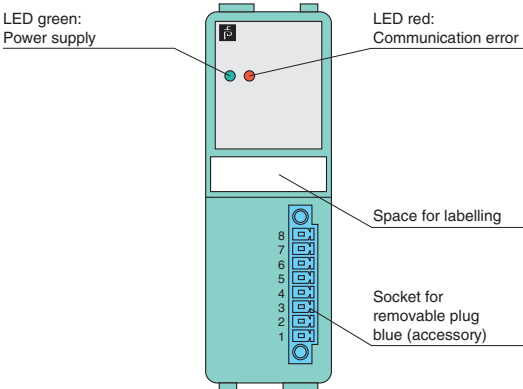

Edition 912907 (US) / 220718 (EU) 06/2011

| Technical data  |   |
|---|---|
| <b>Supply</b>   |   |
| Rated voltage   | 12 V DC, only in connection with the power supplies LB 9***                   |
| Power consumption   | 3 W   |
| <b>Output</b>   |   |
| Number of channels  | 4   |
| Connection  | terminals 1+, 2-, 3+, 4-, 5+, 6-, 7+, 8-                                      |
| Current   | 4 ... 20 mA (0 ... 25 mA)<br>short circuit protected                          |
| Load  | 750 Ω max.  |
| Line fault detection  | min. 1 mA   |
| Response threshold  | ≥ 850 Ω   |
| Watchdog  | output Off 0.5 s after serious fault  |
| <b>Transfer characteristics</b>                                 |   |
| Deviation   | 0.1 % of the input signal range at 20 °C (68 °F)                              |
| Influence of ambient temperature                                | 0.01 %/K of the input signal range  |
| Conversion time   | 58 ms (4 channels)<br>110 ms during HART                                      |
| <b>Ambient conditions</b>                                       |   |
| Ambient temperature   | -20 ... 60 °C (-4 ... 140 °F)   |
| <b>Mechanical specifications</b>                                |   |
| Mass  | approx. 150 g   |
| Dimensions  | 32 x 100 x 103 mm (1.26 x 3.9 x 4 in)   |
| <b>Data for application in connection with Ex-areas</b>         | see page 158 for entity parameters  |
| EC-Type Examination Certificate                                 | PTB 03 ATEX 2042  |
| Group, category, type of protection                             | ⊕ II (1) G [Ex ia] IIC, ⊕ II (1) D [Ex ia]D                                   |
| Supply  | only in connection with the power supplies LB 9***                            |
| Declaration of conformity                                       | PF 08 CERT 1234   |
| Group, category, type of protection, temperature classification | ⊕ II 3 G Ex nA IIC T4   |
| Directive conformity  |   |
| Directive 94/9/EC   | EN 60079-0, EN 60079-11, EN 60079-15,<br>EN 60079-26, EN 61241-0, EN 61241-11 |
| <b>International approvals</b>                                  |   |
| UL approval   | E106378   |
| IECEx approval  | BVS 09.0037X, BVS 08.0011X  |

**Features**

- 4-channel
- Outputs Ex ia
- Analog output module for 0/4 mA ... 20 mA
- Installation in Zone 2 and 22 or Div. 2 and safe area
- HART communication via field bus or service bus
- Module can be exchanged under voltage (hot swap)
- Simulation mode for service operations (forcing)
- Line fault detection (LFD)
- Permanently self-monitoring
- EMC acc. to NAMUR NE 21

**Function**

The analog output drives positioners, proportional valves, I/P converters, or local indicators.  
Open line fault alarms are detected.  
The outputs are galvanically isolated from the bus and the power supply (EN 60079-11).

**Diagrams**

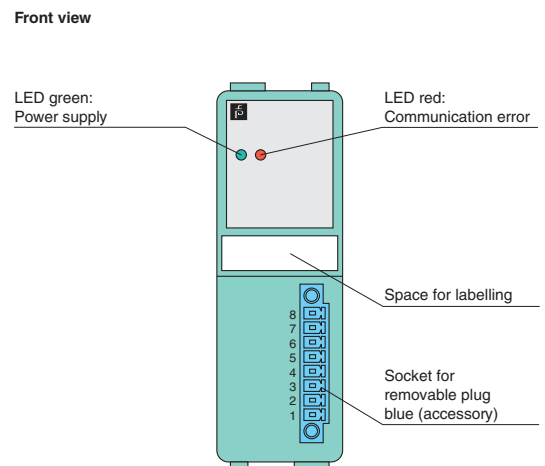
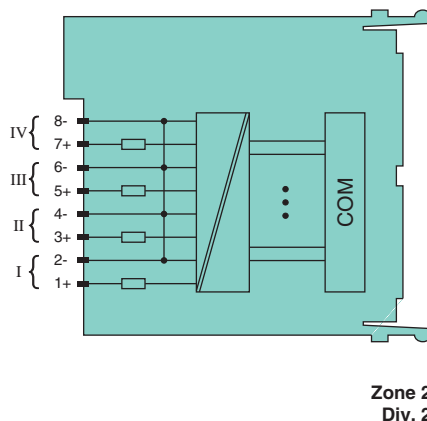
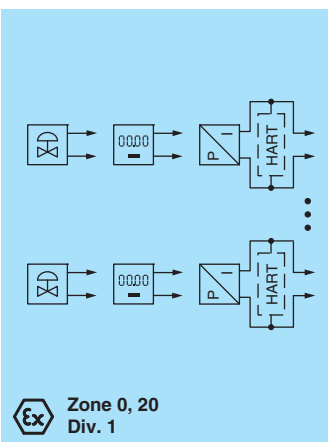

Edition 912907 (US) / 220718 (EU) 06/2011

Subject to modifications without notice

Pepperl+Fuchs Group  
www.pepperl-fuchs.com

USA: +1 330 486 0002  
pa-info@us.pepperl-fuchs.com

Germany: +49 621 776 2222  
pa-info@de.pepperl-fuchs.com

Copyright Pepperl+Fuchs  
Singapore: +65 6779 9091  
pa-info@sg.pepperl-fuchs.com



LB-System

Digital Inputs

Digital Outputs

Analog Inputs

Analog Outputs

Bus Couplers

Power Supplies

Accessories

## ATEX Entity Parameters

| Model Number | Terminals                      | $U_o$ (V) | $I_o$ (mA) | $P_o$ (mW) |
|--------------|--------------------------------|-----------|------------|------------|
| LB 4102 A    | 2, 3+; 4, 5-                   | 27.3      | 87         | 595        |
| LB 4102 C    | 2, 3+; 4, 5-                   | 27.3      | 87         | 595        |
| LB 4105 C    | 1+, 2-; 3+, 4-; 5+, 6-; 7+, 8- | 27.3      | 93         | 635        |
| LB 4105 D    | 1+, 2-; 3+, 4-; 5+, 6-; 7+, 8- | 27.3      | 93         | 635        |



LB-System

Digital  
InputsDigital  
OutputsAnalog  
InputsAnalog  
OutputsBus  
CouplersPower  
Supplies

Accessories

Edition 912907 (US) / 220718 (EU) 06/2011

## Bus Couplers (Gateways)

| Model Number                | Channels per Station <sup>1</sup> |         | Stations per Bus Line <sup>1</sup> |            |            |             |                      | Configuration |             |            |                    |  | Page |
|-----------------------------|-----------------------------------|---------|------------------------------------|------------|------------|-------------|----------------------|---------------|-------------|------------|--------------------|--|------|
|                             | Analog                            | Digital | PROFIBUS DP V1                     | MODBUS RTU | MODBUS TCP | Fieldbus H1 | Service Bus (Option) | via GSD only  | via FDT 1.2 | via System | HART Communication | Mounting in Zone 2 and Zone 22 or Div. 2 |      |
| LB 8106 H***                | 80                                | 184     | 125                                |            |            |             | 119                  | ■             |             | ■          | ■                  | ■  | 160  |
| LB 8107 H***                | 80                                | 184     |                                    | 245        |            |             | 119                  |               | ■           |            | ■                  | ■  | 161  |
| LB 8109 H*** <sup>2 3</sup> | 80                                | 184     | 125                                |            |            |             | 119                  |               | ■           | □          | ■                  | ■  | 162  |
| LB 8110 H***                | 20                                | 40      |                                    |            |            | 1 or 2      | 119                  |               |             | ■          | ■                  | ■  | 163  |
| LB 8111 A                   | 80                                | 184     |                                    |            | 1          |             | 119                  | ■             |             | □          | ■                  | ■  | 164  |

□ depending on the DCS

■ available

<sup>1</sup> see data sheet for details

<sup>2</sup> LB 8109 H\*\*\* compatible replacement for LB 8105 H\*\*\* (spares available) – extended functionality

<sup>3</sup> LB 8109 H\*\*\* compatible replacement for LB 8108 H\*\*\* (spares available) – extended functionality, no time stamp



LB-System

Digital Inputs

Digital Outputs

Analog Inputs

Analog Outputs

Bus Couplers

Power Supplies

Accessories





LB-System

Digital Inputs

Digital Outputs

Analog Inputs

Analog Outputs

Bus Couplers

Power Supplies

Accessories

**Features**

- Interface between the I/O modules and the DCS/PLC
- Bus coupler for 80 analog or 184 digital channels
- Communication via PROFIBUS DP
- HART communication via PROFIBUS DP V1 or service bus
- Configuration via GSD parameters from the control system
- Non-volatile memory for configuration and parameter settings
- Module can be exchanged under voltage (hot swap)
- Installation in Zone 2 and 22 or Div. 2 and safe area
- EMC acc. to NAMUR NE 21

**Function**

The Remote I/O ComUnit, bus coupler or gateway links intrinsically safe and safe inputs and outputs from sensors and actuators to the PROFIBUS.

It makes use of all the regular I/O modules and thus transports signals to and from NAMUR and switch type inputs and high power IS solenoids or even power relays as well as sounders, and alarm LEDs.

The system supplies 4-20 mA transmitters and accepts inputs from 20 mA current sources or temperature sensors. It drives I/P converters and proportional valves and positioners.

The ComUnit supports ONLINE configuration as well as redundancy and HART. It is well integrated into all renowned DCS and PLC systems.

**Technical data**

|   |  |
|---|--|
| <b>Supply</b>   |  |
| Rated voltage   | 5 V DC, only in connection with the power supplies LB 9***   |
| Power consumption   | 2 W  |
| <b>Fieldbus interface</b>                                       |  |
| PROFIBUS DP   |  |
| Baud rate   | up to 1.5 MBit/s   |
| Protocol  | PROFIBUS DP/DP V1 read/write services  |
| Number of stations per bus line                                 | ≤ 125 (PROFIBUS), ≤ 119 (service bus)  |
| Number of channels per station                                  | ≤ 80 analog, ≤ 184 digital (standard configuration)  |
| Number of stations per bus segment                              | ≤ 31 (RS 485 standard)   |
| Number of repeaters between Master and Slave                    | max. 3   |
| Supported I/O modules   | all LB Remote I/O modules  |
| Bus length  | ≤ 1000 m (FOL, 1.5 Mbaud),<br>≤ 1000 m (copper cable, 187.5 kBd),<br>≤ 200 m (copper cable, 1.5 MBd) |
| PROFIBUS address  | 0 ... 126 (ex works standard: 126)   |
| <b>Ambient conditions</b>                                       |  |
| Ambient temperature   | -20 ... 60 °C (-4 ... 140 °F)  |
| <b>Mechanical specifications</b>                                |  |
| Mass  | approx. 120 g  |
| Dimensions  | 32 x 100 x 103 mm (1.26 x 3.9 x 4 in)  |
| <b>Data for application in connection with Ex-areas</b>         |  |
| Supply  | only in connection with the power supplies LB 9***   |
| Declaration of conformity                                       | PF 08 CERT 1234  |
| Group, category, type of protection, temperature classification | ⊕ II 3 G Ex nA IIC T4  |
| Directive conformity  |  |
| Directive 94/9/EC   | EN 60079-0, EN 60079-15  |
| <b>International approvals</b>                                  |  |
| UL approval   | E106378  |
| IECEX approval  | BVS 09.0037X   |

**Diagrams**

Front view

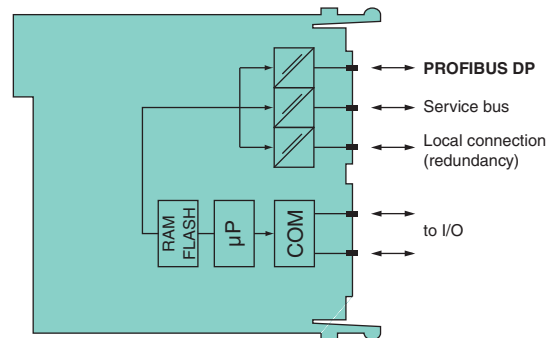
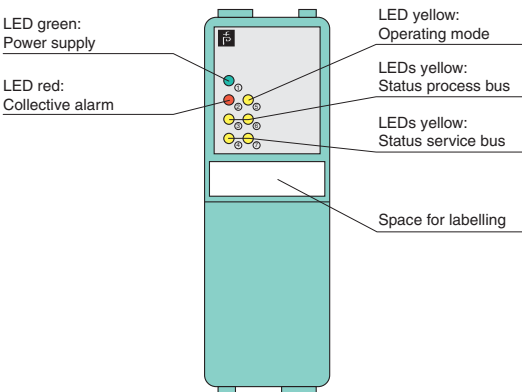

Zone 2  
Div. 2

Edition 912907 (US) / 220718 (EU) 06/2011

| Technical data  |  |
|---|--|
| <b>Supply</b>   |  |
| Rated voltage   | 5 V DC, only in connection with the power supplies LB 9***     |
| Power consumption   | 2 W  |
| <b>Fieldbus interface</b>                                       |  |
| MODBUS RTU  |  |
| Baud rate   | max. 38.4 kBit/s   |
| Number of stations per bus line                                 | ≤245 (MODBUS), ≤ 119 (service bus)                             |
| Number of channels per station                                  | ≤80 analog, ≤184 digital (standard configuration)              |
| Number of stations per bus segment                              | ≤31 (RS 485 standard)  |
| Number of repeaters between Master and Slave                    | max. 3   |
| Supported I/O modules   | all LB Remote I/O modules                                      |
| Bus length  | ≤ 1200 m (FOL, 38.4 kBd),<br>≤ 1200 m (copper cable, 38.4 kBd) |
| MODBUS address  | standard compliant<br>(ex works standard: 126)                 |
| Service bus address   | max. 119, redundant address = base + 128 (automatic)           |
| <b>Ambient conditions</b>                                       |  |
| Ambient temperature   | -20 ... 60 °C (-4 ... 140 °F)                                  |
| <b>Mechanical specifications</b>                                |  |
| Mass  | approx. 120 g  |
| Dimensions  | 32 x 100 x 103 mm (1.26 x 3.9 x 4 in)                          |
| <b>Data for application in connection with Ex-areas</b>         |  |
| Supply  | only in connection with the power supplies LB 9***             |
| Declaration of conformity                                       | PF 08 CERT 1234  |
| Group, category, type of protection, temperature classification | Ⓜ II 3 G Ex nA IIC T4  |
| Directive conformity  |  |
| Directive 94/9/EC   | EN 60079-0, EN 60079-15  |
| <b>International approvals</b>                                  |  |
| UL approval   | E106378  |
| IECEx approval  | BVS 09.0037X   |

**Features**

- Interface between the I/O modules and the DCS/PLC
- Bus coupler for 80 analog or 184 digital channels
- Communication via MODBUS RTU
- HART communication via service bus
- Configuration via FDT 1.2 DTM
- Non-volatile memory for configuration and parameter settings
- Module can be exchanged under voltage (hot swap)
- Installation in Zone 2 and 22 or Div. 2 and safe area
- EMC acc. to NAMUR NE 21

**Function**

The Remote I/O ComUnit, bus coupler or gateway links intrinsically safe and safe inputs and outputs from sensors and actuators to the Modbus.

It makes use of all the regular I/O modules and thus transports signals to and from NAMUR and switch type inputs and high power IS solenoids or even power relays as well as sounders, and alarm LEDs.

The system supplies 4-20 mA transmitters and accepts inputs from 20 mA current sources or temperature sensors. It drives I/P converters and proportional valves and positioners.

The ComUnit supports ONLINE configuration as well as redundancy and HART. It is well integrated into all renowned DCS and PLC systems.

**Diagrams**

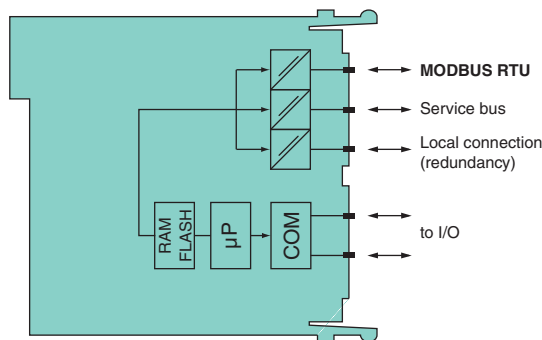

Front view

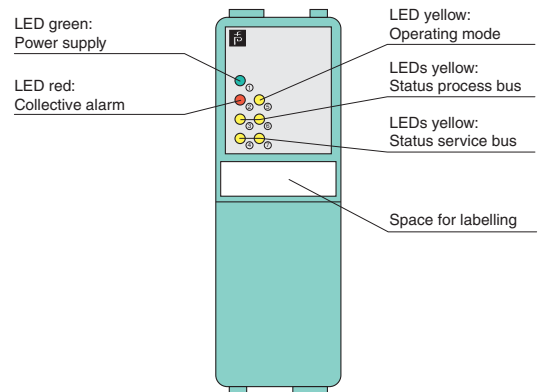

Zone 2  
Div. 2

Edition 912907 (US) / 220718 (EU) 06/2011

Subject to modifications without notice

Pepperl+Fuchs Group  
www.pepperl-fuchs.com

USA: +1 330 486 0002  
pa-info@us.pepperl-fuchs.com

Germany: +49 621 776 2222  
pa-info@de.pepperl-fuchs.com

Copyright Pepperl+Fuchs  
Singapore: +65 6779 9091  
pa-info@sg.pepperl-fuchs.com



LB-System

Digital Inputs

Digital Outputs

Analog Inputs

Analog Outputs

Bus Couplers

Power Supplies

Accessories



LB-System

Digital Inputs

Digital Outputs

Analog Inputs

Analog Outputs

Bus Couplers

Power Supplies

Accessories

**Features**

- Interface between the I/O modules and the DCS/PLC
- Bus coupler for 80 analog or 184 digital channels
- Communication via PROFIBUS DP
- HART communication via PROFIBUS DP V1 or service bus
- Configuration via FDT 1.2 DTM
- Configuration in run (CiR) for any DCS
- Installation in Zone 2 and 22 or Div. 2 and safe area
- EMC acc. to NAMUR NE 21

**Function**

The Remote I/O ComUnit, bus coupler or gateway links intrinsically safe and safe inputs and outputs from sensors and actuators to the PROFIBUS.

It makes use of all the regular I/O modules and thus transports signals to and from NAMUR and switch type inputs and high power IS solenoids or even power relays as well as sounders, and alarm LEDs.

The system supplies 4-20 mA transmitters and accepts inputs from 20 mA current sources or temperature sensors. It drives I/P converters and proportional valves and positioners.

The ComUnit supports ONLINE configuration as well as redundancy and HART. It is well integrated into all renowned DCS and PLC systems.

A universal setting allows you to configure a running system without a PROFIBUS restart even in non-redundant systems (CiR functionality).

**Technical data**

**Supply**

Rated voltage 5 V DC, only in connection with the power supplies LB 9\*\*\*

Power consumption 2 W

**Fieldbus interface**

**PROFIBUS DP**

Baud rate up to 1.5 MBit/s

Protocol PROFIBUS DP/DP V1 read/write services

Number of stations per bus line ≤ 125 (PROFIBUS), ≤ 119 (service bus)

Number of channels per station ≤ 80 analog, ≤ 184 digital (standard configuration)

Number of stations per bus segment ≤ 31 (RS 485 standard)

Number of repeaters between Master and Slave max. 3

Supported I/O modules all LB Remote I/O modules

Bus length ≤ 1000 m (FOL, 1.5 Mbaud), ≤ 1000 m (copper cable, 187.5 kBd), ≤ 200 m (copper cable, 1.5 MBd)

PROFIBUS address 0 ... 126 (ex works standard: 126)

**Ambient conditions**

Ambient temperature -20 ... 60 °C (-4 ... 140 °F)

**Mechanical specifications**

Mass approx. 120 g

Dimensions 32 x 100 x 103 mm (1.26 x 3.9 x 4 in)

**Data for application in connection with Ex-areas**

Supply only in connection with the power supplies LB 9\*\*\*

Declaration of conformity PF 08 CERT 1234

Group, category, type of protection, temperature classification Ⓜ II 3 G Ex nA IIC T4

**Directive conformity**

Directive 94/9/EC EN 60079-0, EN 60079-15

**International approvals**

UL approval E106378

IECEx approval BVS 09.0037X

**Diagrams**

Front view

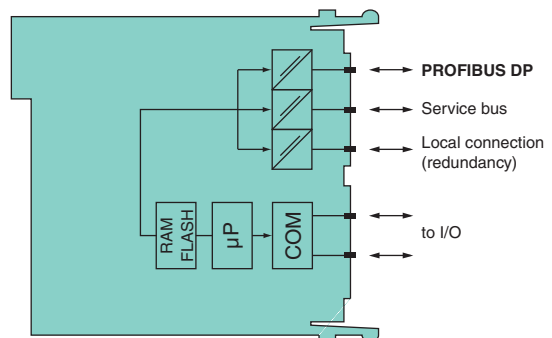
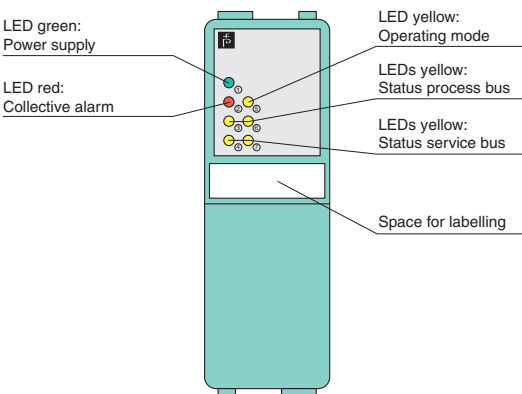

Zone 2  
Div. 2

Edition 912907 (US) / 220718 (EU) 06/2011



LB-System

Digital Inputs

Digital Outputs

Analog Inputs

Analog Outputs

Bus Couplers

Power Supplies

Accessories

**Technical data**

|   |  |
|---|--|
| <b>Supply</b>   |  |
| Rated voltage   | 5 V DC, only in connection with the power supplies LB 9***   |
| <b>Fieldbus interface</b>                                       |  |
| FOUNDATION Fieldbus   |  |
| Baud rate   | 31.25 kBit/s, MBP  |
| Protocol  | H1 to IEC 1158-2   |
| Number of stations per bus line                                 | 1 or 2, depending on the required response times   |
| Number of channels per station                                  | ≤20 analog, ≤40 digital  |
| Supported I/O modules   | 5 slots, to be filled with (combinations possible):<br>1*08 digital input, 8-channel, NAMUR<br>3104 analog input, 4-channel, 20 mA (HART via handheld only), 3*05 analog input, 4-channel, 20 mA (HART via service bus)<br>4104 analog output, 4-channel, 20 mA (HART via handheld), 4*05 analog output, 4-channel, 20 mA (HART via service bus)<br>5*04 Pt100 RTD input, 4-channel, 5*05 thermocouple input, 4-channel<br>6005 relay output, 4-channel, 230 V, 6006 relay output, 8-channel, 24 V, 6*08 digital output, 8-channel, Ex-i, 6*10-6*15 digital output, 4-channel, Ex-i power<br>* = variable (0 = non-IS, 1 = IS) |
| Bus length  | ≤1900 m (must not be exceeded by the sum of all trunk and spur lines)  |
| Spur length   | ≤120 m (depending on the number of field devices. Modular I/O station = 1 field device)  |
| <b>Ambient conditions</b>                                       |  |
| Ambient temperature   | -20 ... 60 °C (-4 ... 140 °F)  |
| <b>Mechanical specifications</b>                                |  |
| Mass  | approx. 150 g  |
| Dimensions  | 32 x 100 x 103 mm (1.26 x 3.9 x 4 in)  |
| <b>Data for application in connection with Ex-areas</b>         |  |
| Supply  | only in connection with the power supplies LB 9***   |
| Declaration of conformity                                       | PF 08 CERT 1234  |
| Group, category, type of protection, temperature classification | ⊕ II 3 G Ex nA IIC T4  |
| Directive conformity  |  |
| Directive 94/9/EC   | EN 60079-0, EN 60079-15  |
| <b>International approvals</b>                                  |  |
| UL approval   | E106378  |
| IECEx approval  | BVS 09.0037X   |

**Features**

- Interface between the I/O modules and the DCS/PLC
- Bus coupler for 20 analog or 40 digital channels
- Communication via FOUNDATION fieldbus H1
- HART communication via service bus
- Configured via the DCS
- Non-volatile memory for configuration and parameter settings
- Supports multichannel I/O modules
- Installation in Zone 2 and 22 or Div. 2 and safe area
- EMC acc. to NAMUR NE 21

**Function**

The ComUnit, bus coupler or gateway links intrinsically safe inputs and outputs from sensors and actuators to FOUNDATION Fieldbus.

It makes use of dual width I/O modules and thus transports signals from NAMUR and switch type inputs and high power IS solenoids or even power relays as well as sounders, and alarm LEDs.

The system supplies 4-20 mA transmitters and accepts inputs from 20 mA current sources or temperature sensors. It drives I/P converters and proportional valves and positioners.

The ComUnit supports ONLINE configuration as well as HART. It is well integrated into renowned DCS and PLC systems.

**Diagrams**

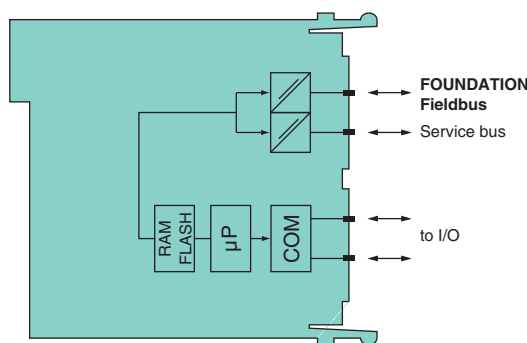

Zone 2  
Div. 2

Front view

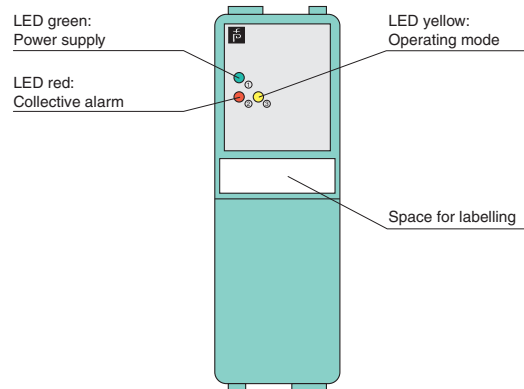

Edition 912907 (US) / 220718 (EU) 06/2011

Subject to modifications without notice

Pepperl+Fuchs Group  
www.pepperl-fuchs.com

USA: +1 330 486 0002  
pa-info@us.pepperl-fuchs.com

Germany: +49 621 776 2222  
pa-info@de.pepperl-fuchs.com

Copyright Pepperl+Fuchs  
Singapore: +65 6779 9091  
pa-info@sg.pepperl-fuchs.com



LB-System

Digital Inputs

Digital Outputs

Analog Inputs

Analog Outputs

Bus Couplers

Power Supplies

Accessories

**Features**

- Interface between the I/O modules and the DCS/PLC
- Bus coupler for 80 analog or 184 digital channels
- Communication via MODBUS TCP
- HART communication via MODBUS TCP or service bus
- Configuration via FDT 1.2 DTM
- Non-volatile memory for configuration and parameter settings
- Module can be exchanged under voltage (hot swap)
- Installation in Zone 2 and 22 or Div. 2 and safe area
- EMC acc. to EN 61326

**Function**

The Modbus TCP Remote I/O ComUnit or gateway brings intrinsically safe inputs and outputs from sensors and actuators to the Ethernet.

It makes use of all the regular I/O modules and thus transports signals to and from NAMUR and switch type inputs and high power IS solenoids or even power relays as well as sounders, and alarm LEDs.

The system supplies 4-20 mA transmitters and accepts inputs from 20 mA current sources or temperature sensors. It drives I/P converters and proportional valves and positioners.

Industrial Ethernet hardware is familiar to most users not only through office applications but also through the architecture on which DCS systems are based.

**Technical data**

|   |  |
|---|--|
| <b>Supply</b>   |  |
| Rated voltage   | 5 V DC, only in connection with the power supplies LB 9*** |
| Power consumption   | 2.5 W  |
| <b>Ethernet Interface</b>                                       |  |
| Connection type   | RJ-45, via backplane                                       |
| Transfer rate   | 10 MBit/s  |
| Station connection  | directly to DCS or PLC or via hubs or switches             |
| Bus length  | ≤ 100 m (Ethernet standard)                                |
| Addressing  | IP address assigned via Ethernet                           |
| Number of channels per station                                  | ≤ 80 analog, ≤ 184 digital                                 |
| Supported I/O modules   | all LB Remote I/O modules                                  |
| <b>Service interface</b>  |  |
| Connection  | 9-pole to RS 485 standard, Sub-D                           |
| <b>Ambient conditions</b>                                       |  |
| Ambient temperature   | -20 ... 60 °C (-4 ... 140 °F)                              |
| <b>Mechanical specifications</b>                                |  |
| Mass  | approx. 150 g  |
| Dimensions  | 32 x 100 x 103 mm (1.26 x 3.9 x 4 in)                      |
| <b>Data for application in connection with Ex-areas</b>         |  |
| Supply  | only in connection with the power supplies LB 9***         |
| Declaration of conformity                                       | PF 08 CERT 1234  |
| Group, category, type of protection, temperature classification | Ex II 3 G Ex nA IIC T4                                     |
| Directive conformity  |  |
| Directive 94/9/EC   | EN 60079-0, EN 60079-15                                    |
| <b>International approvals</b>                                  |  |
| UL approval   | E106378  |
| IECEX approval  | BVS 09.0037X   |

**Diagrams**

Front view

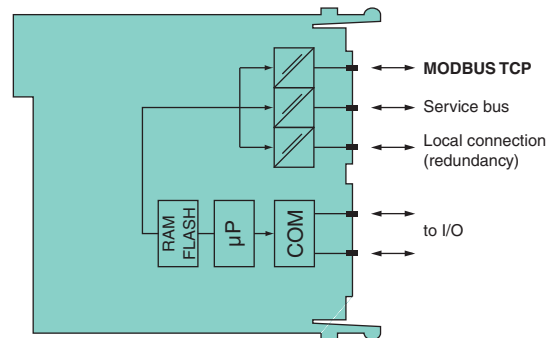
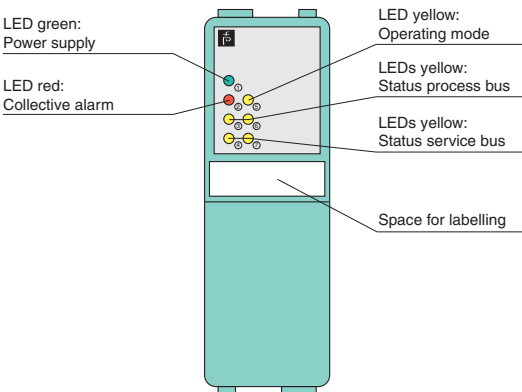

Zone 2  
Div. 2

Edition 912907 (US) / 220718 (EU) 06/2011

Power Supplies

| Model Number | Supplied Devices |              | Supply 24 V DC | Redundant Supply Possible | Mounting in Zone 2 and Zone 22 | Mounting in Div. 2 | Page |
|--------------|------------------|--------------|----------------|---------------------------|--------------------------------|--------------------|------|
|              | I/O Module Slots | Bus Couplers |                |                           |                                |                    |      |
| LB 9006 C    | 12               | 1            | ■              | ■                         | ■                              | ■                  | 166  |



**LB-System**

Digital Inputs

Digital Outputs

Analog Inputs

Analog Outputs

Bus Couplers

Power Supplies

Accessories

Edition 912907 (US) / 220718 (EU) 06/2011



LB-System

Digital Inputs

Digital Outputs

Analog Inputs

Analog Outputs

Bus Couplers

Power Supplies

Accessories

**Features**

- Power supply for 24 V (replaces LB 9006 A)
- permits vertical or horizontal mounting in Zone 2
- Suitable for the supply of 12 I/O modules and 1 bus coupler
- Use three power supplies for redundancy
- Installation in Zone 2 and 22 or Div. 2 and safe area
- Module can be exchanged under voltage (hot swap)
- EMC acc. to NAMUR NE 21
- Galvanic isolation to mains

**Function**

The power supply provides power for the I/O modules and com units mounted on the backplane.

Power supplies can be connected in parallel to achieve redundancy. Two power supplies may be needed, depending on the number and power consumption of the modules used. A third power supply then handles redundancy.

Input and output are galvanically isolated from each other (EN 61010-1).

**Technical data**

**Supply**

|                   |   |
|-------------------|---|
| Connection        | backplane bus   |
| Rated voltage     | 24 V DC (18 - 32 V DC)  |
| Fusing            | 4 A mtg (internal), 5 A mtg (external)  |
| Power dissipation | ca. 12% of power consumption  |
| Power consumption | ≤47 W, available output power for Zone 2 applications 5 W (5V), 20 W (12V), else 5 W (5V), 35 W (12V). Parallel connection with other LB 9006C (autom. power sharing) |
| Inrush current    | 1.5 A (10 ms)   |

**Output**

|         |                              |
|---------|------------------------------|
| Voltage | 5 V DC +/- 5%, 12 V DC +/-2% |
|---------|------------------------------|

**Ambient conditions**

|                     |   |
|---------------------|---|
| Ambient temperature | -20 ... 60 °C (-4 ... 140 °F), 70 °C (non-Ex) |
| Storage temperature | -25 ... 85 °C (-13 ... 185 °F)                |

**Mechanical specifications**

|                   |                                       |
|-------------------|---------------------------------------|
| Protection degree | IP20 (module), mounted on backplane   |
| Connection        | via connectors on the backplane       |
| Mass              | approx. 220 g                         |
| Dimensions        | 32 x 100 x 103 mm (1.26 x 3.9 x 4 in) |

**Data for application in connection with Ex-areas**

|   |                       |
|---|-----------------------|
| Declaration of conformity                                       | PF 08 CERT 1234       |
| Group, category, type of protection, temperature classification | Ⓜ II 3 G Ex nA IIC T4 |

|                      |                         |
|----------------------|-------------------------|
| Directive conformity |                         |
| Directive 94/9/EC    | EN 60079-0, EN 60079-15 |

**International approvals**

|                |              |
|----------------|--------------|
| UL approval    | E106378      |
| IECEx approval | BVS 09.0037X |

**Diagrams**

Front view

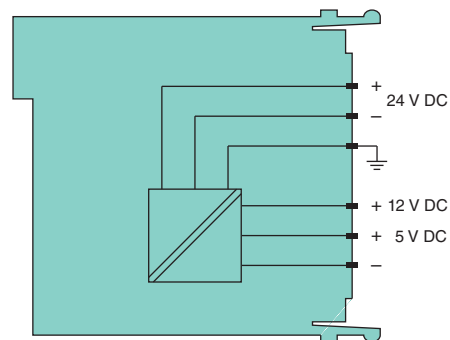
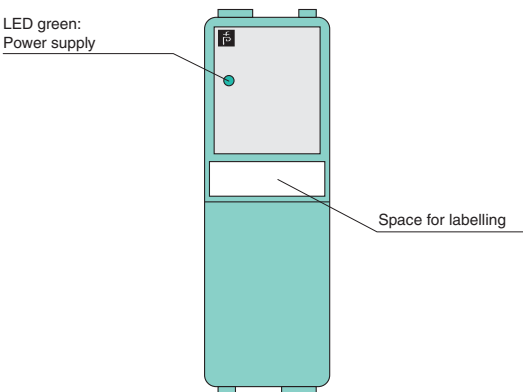

Zone 2  
Div. 2

Edition 912907 (US) / 220718 (EU) 06/2011

## Terminal Blocks

| Model Number | Terminal Block       |                           |                            |                      |                                 | Labeled             | Cover for Terminal Block with Screw Terminals | Number of Poles | Housing Color |      | Page |
|--------------|----------------------|---------------------------|----------------------------|----------------------|---------------------------------|---------------------|---|-----------------|---------------|------|------|
|              | with Screw Terminals | with Wire Clamp Terminals | with Front Screw Terminals | Cold Junction Module | Voltage Divider for 10 V Inputs |                     |   |                 | Green         | Blue |      |
| LB 9007 A    | ■                    |                           |                            |                      |                                 | 1 ... 6             |   | 6               | ■             |      | 170  |
| LB 9008 A    |                      |                           |                            |                      |                                 |                     | ■   | 6               | ■             |      | 170  |
| LB 9009 A    |                      | ■                         |                            |                      |                                 | 1 ... 6             |   | 6               | ■             |      | 170  |
| LB 9010 A    |                      |                           |                            |                      |                                 |                     | ■   | 8               | ■             |      | 170  |
| LB 9011 A    |                      |                           |                            | ■                    |                                 | 1 ... 6             |   | 6               | ■             |      | 170  |
| LB 9012 A    | ■                    |                           |                            |                      | ■                               |                     | ■   | 6               | ■             |      | 170  |
| LB 9013 A    | ■                    |                           |                            |                      |                                 | 1 ... 8             |   | 8               | ■             |      | 170  |
| LB 9014 A    | ■                    |                           |                            |                      |                                 | 1 ... 8<br>9 ... 16 |   | 2 x 8           | ■             |      | 170  |
| LB 9015 A    |                      | ■                         |                            |                      |                                 | 1 ... 8             |   | 8               | ■             |      | 170  |
| LB 9016 A    |                      | ■                         |                            |                      |                                 | 1 ... 8<br>9 ... 16 |   | 2 x 8           | ■             |      | 170  |
| LB 9017 A    |                      |                           | ■                          |                      |                                 | 1 ... 6             |   | 6               | ■             |      | 170  |
| LB 9018 A    |                      |                           | ■                          |                      |                                 | 1 ... 8             |   | 8               | ■             |      | 170  |
| LB 9019 A    |                      |                           | ■                          |                      |                                 | 1 ... 8<br>9 ... 16 |   | 2 x 8           | ■             |      | 170  |
| LB 9107 A    | ■                    |                           |                            |                      |                                 | 1 ... 6             |   | 6               |               | ■    | 171  |
| LB 9107 P    |                      | ■                         |                            |                      |                                 | 1 ... 6             |   | 6               |               | ■    | 171  |
| LB 9108 A    |                      |                           |                            |                      |                                 |                     | ■   | 6               |               | ■    | 171  |
| LB 9111 A    |                      |                           |                            | ■                    |                                 | 1 ... 6             |   | 6               |               | ■    | 171  |
| LB 9112 A    |                      |                           |                            | ■                    |                                 |                     |   | 6               |               | ■    | 171  |
| LB 9113 A    | ■                    |                           |                            |                      |                                 | 1 ... 8             |   | 8               |               | ■    | 171  |
| LB 9115 A    |                      | ■                         |                            |                      |                                 | 1 ... 8             |   | 8               |               | ■    | 171  |
| LB 9116 A    |                      | ■                         |                            |                      |                                 | 1 ... 8<br>9 ... 16 |   | 2 x 8           |               | ■    | 171  |
| LB 9117 A    |                      |                           | ■                          |                      |                                 | 1 ... 6             |   | 6               |               | ■    | 171  |
| LB 9118 A    |                      |                           | ■                          |                      |                                 | 1 ... 8             |   | 8               |               | ■    | 171  |
| LB 9119 A    |                      |                           | ■                          |                      |                                 | 1 ... 8<br>9 ... 16 |   | 2 x 8           |               | ■    | 171  |
| LB 9120 A    |                      |                           |                            |                      |                                 |                     | ■   | 8               |               | ■    | 171  |
| LB 9124 A    | ■                    |                           |                            |                      |                                 | 1 ... 8<br>9 ... 16 |   | 2 x 8           |               | ■    | 171  |



LB-System

Digital Inputs

Digital Outputs

Analog Inputs

Analog Outputs

Bus Couplers

Power Supplies

Accessories



Connectors with Switchable Bus Termination Resistor

| Model Number | Description                                  | Page |
|--------------|--|------|
| LB 9001 A    | Sub-D connector, 9-pin, left cable entry     | 172  |
| LB 9002 A    | Sub-D connector, 9-pin, vertical cable entry | 172  |
| LB 9003 A    | Sub-D connector, 9-pin, left cable entry     | 172  |

Backplanes

| Model Number | Backplane Type |                          |                     |                     | Max. Number of Modules |                            | Fieldbus Type |                |            |               |                        |                              |                                |                    | Page |
|--------------|----------------|--------------------------|---------------------|---------------------|------------------------|----------------------------|---------------|----------------|------------|---------------|------------------------|------------------------------|--------------------------------|--------------------|------|
|              | Base Backplane | Redundant Base Backplane | Redundant Backplane | Extension Backplane | Single Width Modules   | or<br>Double Width Modules | PROFIBUS DP   | PROFIBUS DP V1 | MODBUS RTU | MODBUS TCP/IP | FOUNDATION Fieldbus H1 | Determined by Base Backplane | Mounting in Zone 2 and Zone 22 | Mounting in Div. 2 |      |
| LB 9022 A    |                | ■                        |                     |                     | 22                     | 11                         | ■             | ■              | ■          |               |                        |                              | ■                              | ■                  | 174  |
| LB 9022 E    |                | ■                        |                     |                     | 22                     | 11                         |               |                |            | ■             |                        |                              | ■                              | ■                  | 175  |
| LB 9022 S    |                | ■                        |                     |                     | 22                     | 11                         | ■             | ■              | ■          |               |                        |                              | ■                              | ■                  | 177  |
| LB 9023 A    | ■              |                          |                     |                     | 8                      | 4                          | ■             | ■              | ■          |               |                        |                              | ■                              | ■                  | 179  |
| LB 9024 A    |                |                          |                     | ■                   | 24                     | 12                         |               |                |            |               |                        | ■                            | ■                              | ■                  | 176  |
| LB 9024 S    |                |                          |                     | ■                   | 24                     | 12                         |               |                |            |               |                        | ■                            | ■                              | ■                  | 178  |
| LB 9025 A    |                |                          |                     | ■                   | 8                      | 4                          |               |                |            |               |                        | ■                            | ■                              | ■                  | 180  |
| LB 9026 A    | ■              |                          |                     |                     | 16                     | 8                          | ■             | ■              | ■          |               |                        |                              | ■                              | ■                  | 181  |
| LB 9027 A    |                |                          |                     | ■                   | 16                     | 8                          |               |                |            |               |                        | ■                            | ■                              | ■                  | 182  |
| LB 9029 A    |                |                          | ■                   |                     | 12                     | 6                          | ■             | ■              | ■          |               |                        |                              | ■                              | ■                  | 183  |
| LB 9035 A    | ■              |                          |                     |                     |                        | 5                          |               |                |            |               | ■                      |                              | ■                              | ■                  | 184  |

- LB-System
- Digital Inputs
- Digital Outputs
- Analog Inputs
- Analog Outputs
- Bus Couplers
- Power Supplies
- Accessories

## Field Units (Enclosures)

| Model Number          | Type       |                      | max. Number of Slots | Material        |                 | Fieldbus Type |                |            |               |                        |                                | Page |                    |
|-----------------------|------------|----------------------|----------------------|-----------------|-----------------|---------------|----------------|------------|---------------|------------------------|--------------------------------|------|--------------------|
|                       | Field Unit | Redundant Field Unit |                      | Stainless Steel | Polyester (GRP) | PROFIBUS DP   | PROFIBUS DP V1 | MODBUS RTU | MODBUS TCP/IP | FOUNDATION Fieldbus H1 | Mounting in Zone 2 and Zone 22 |      | Mounting in Div. 2 |
| LB 9508-S92-0-0-1-0-0 | ■          |                      | 8                    | ■               |                 | ■             | ■              | ■          |               |                        | ■                              | ■    | 185                |
| LB 9510-S90-0-0-1-0-F | ■          |                      | 5                    | ■               |                 |               |                |            |               | ■                      | ■                              | ■    | 186                |
| LB 9513-PB0-0-0-1-0-0 |            | ■                    | 12                   |                 | ■               | ■             | ■              | ■          |               |                        | ■                              | ■    | 187                |
| LB 9516-PB0-0-0-1-0-0 | ■          |                      | 16                   |                 | ■               | ■             | ■              | ■          |               |                        | ■                              | ■    | 188                |
| LB 9547-S70-0-0-1-0-M |            | ■                    | 46                   | ■               |                 |               |                |            | ■             |                        | ■                              | ■    | 189                |
| LB 9547-S70-0-0-1-0-0 |            | ■                    | 46                   | ■               |                 | ■             | ■              | ■          |               |                        | ■                              | ■    | 190                |

## Further Accessories

| Model Number | Description                             | Page |
|--------------|---|------|
| KF-CP        | Coding pins, packaging unit 20 x 6, red | 173  |
| F-NR-Ex1     | NAMUR Resistance Network                | 173  |
| LB 9199 A    | Dummy I/O module                        | 173  |



LB-System

Digital  
InputsDigital  
OutputsAnalog  
InputsAnalog  
OutputsBus  
CouplersPower  
Supplies

Accessories



Terminal blocks

Terminal blocks, 6-pole, green

**LB 9007 A**  
with screw terminals  
6-pole, labeled 1 ... 6

**LB 9008 A**  
Cover for terminal block with screw terminals

**LB 9009 A**  
with wire clamp terminals  
6-pole, labeled 1 ... 6

**LB 9011 A**  
Cold junction module with hood  
6-pole, labeled 1 ... 6

**LB 9012 A**  
with screw terminals, voltage divider and hood, for 10 V inputs

**LB 9017 A**  
with front screw terminals  
6-pole, labeled 1 ... 6

Terminal blocks, 8-pole, green

**LB 9010 A**  
Cover for terminal block with screw terminals

**LB 9013 A**  
with screw terminals  
8-pole, labeled 1 ... 8

**LB 9014 A**  
with screw terminals  
2 x 8-pole, labeled 1 ... 8 and 9 ... 16

**LB 9015 A**  
with wire clamp terminals  
8-pole, labeled 1 ... 8

**LB 9016 A**  
with wire clamp terminals  
2 x 8-pole, labeled 1 ... 8 and 9 ... 16

**LB 9018 A**  
with front screw terminals  
8-pole, labeled 1 ... 8

**LB 9019 A**  
with front screw terminals  
2 x 8-pole, labeled 1 ... 8 and 9 ... 16

Terminal blocks with screw terminals

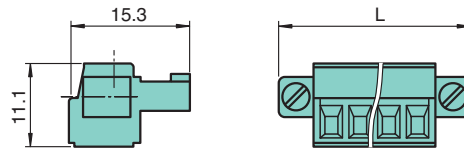

Technical data

|                                  |  |
|----------------------------------|--|
| <b>Mechanical specifications</b> | suitable for hood cover (below)          |
| <b>Dimensions</b>                | 6-pole: L = 33.3 mm, 8-pole: L = 40.9 mm |

Terminal blocks with wire clamp terminals

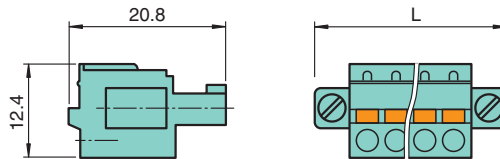

Technical data

|                                  |  |
|----------------------------------|--|
| <b>Mechanical specifications</b> |  |
| <b>Dimensions</b>                | 6-pole: L = 33.3 mm, 8-pole: L = 40.9 mm |

Terminal blocks with front screw terminals

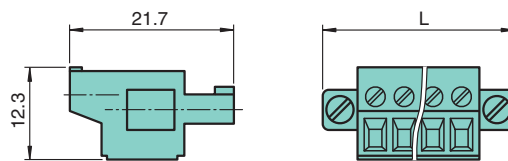

Technical data

|                                  |  |
|----------------------------------|--|
| <b>Mechanical specifications</b> |  |
| <b>Dimensions</b>                | 6-pole: L = 33.3 mm, 8-pole: L = 40.9 mm |

Cover for terminal blocks with screw terminals

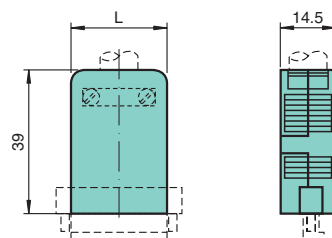

Technical data

|                                  |  |
|----------------------------------|--|
| <b>Mechanical specifications</b> |  |
| <b>Dimensions</b>                | 6-pole: L = 19.1 mm, 8-pole: L = 26.7 mm |

**Note:**  
Use green terminal blocks for Non-IS or Ex ic applications.

LB-System  
Digital Inputs  
Digital Outputs  
Analog Inputs  
Analog Outputs  
Bus Couplers  
Power Supplies  
Accessories

Edition 912907 (US) / 220718 (EU) 06/2011

## Terminal blocks with screw terminals

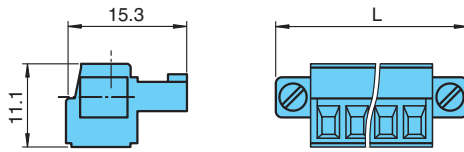

## Technical data

## Mechanical specifications

suitable for hood cover (below)

## Dimensions

6-pole: L = 33.3 mm, 8-pole: L = 40.9 mm

## Terminal blocks with wire clamp terminals

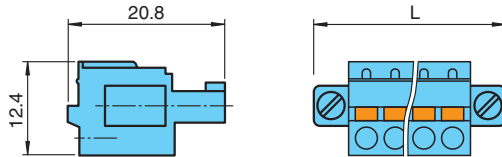

## Technical data

## Mechanical specifications

## Dimensions

6-pole: L = 33.3 mm, 8-pole: L = 40.9 mm

## Terminal blocks with front screw terminals

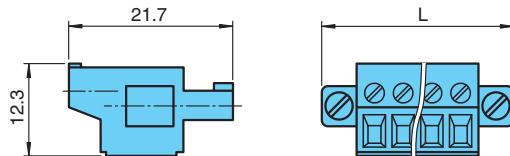

## Technical data

## Mechanical specifications

## Dimensions

6-pole: L = 33.3 mm, 8-pole: L = 40.9 mm

## Cover for terminal blocks with screw terminals

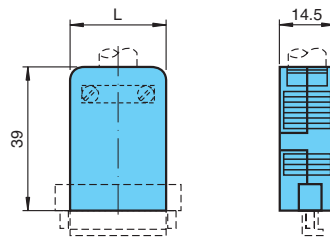

## Technical data

## Mechanical specifications

## Dimensions

6-pole: L = 19.1 mm, 8-pole: L = 26.7 mm

## Note:

Use blue terminal blocks for IS or Ex ia, Ex ib applications.

## Terminal blocks, 6-pole, blue

## LB 9107 A

with screw terminals  
6-pole, labeled 1 ... 6

## LB 9107 P

with wire clamp terminals  
6-pole, labeled 1 ... 6

## LB 9108 A

Cover for terminal block with screw terminals

## LB 9111 A

Cold junction module with hood  
6-pole, labeled 1 ... 6

## LB 9112 A

Cold junction module

## LB 9117 A

with front screw terminals  
6-pole, labeled 1 ... 6

## Terminal blocks, 8-pole, blue

## LB 9113 A

with screw terminals  
8-pole, labeled 1 ... 8

## LB 9115 A

with wire clamp terminals  
8-pole, labeled 1 ... 8

## LB 9116 A

with wire clamp terminals  
2 x 8-pole, labeled 1 ... 8 and 9 ... 16

## LB 9118 A

with front screw terminals  
8-pole, labeled 1 ... 8

## LB 9119 A

with front screw terminals  
2 x 8-pole, labeled 1 ... 8 and 9 ... 16

## LB 9120 A

Cover for terminal block with screw terminals

## LB 9124 A

with screw terminals  
2 x 8-pole, labeled 1 ... 8 and 9 ... 16

LB-System

Digital Inputs

Digital Outputs

Analog Inputs

Analog Outputs

Bus Couplers

Power Supplies

Accessories



LB-System

Digital Inputs

Digital Outputs

Analog Inputs

Analog Outputs

Bus Couplers

Power Supplies

Accessories

Bus connectors

9-pin Sub-D Connector

LB 9001 A

Features

- For PROFIBUS DP, MODBUS, RS 485
- Left cable entry
- With switchable bus termination resistor
- With connector for bus monitor or class 2 master

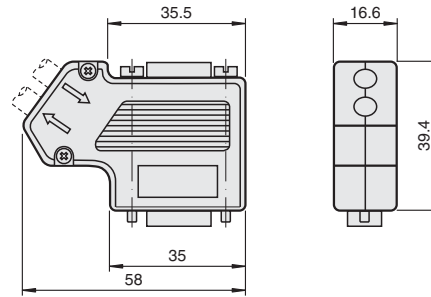

9-pin Sub-D Connector

LB 9002 A

Features

- For PROFIBUS DP, MODBUS, RS 485
- Vertical cable entry
- With switchable bus termination resistor

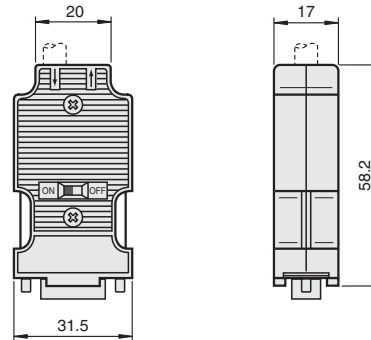

9-pin Sub-D Connector

LB 9003 A

Features

- For PROFIBUS DP, MODBUS, RS 485
- Left cable entry
- With switchable bus termination resistor
- With connector for bus monitor or class 2 master

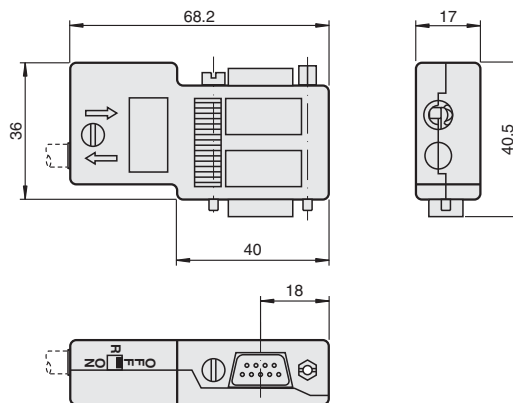

Further Accessories

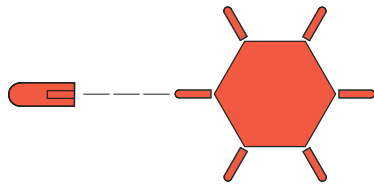

Technical data

Mechanical specifications

|            |                                       |
|------------|---------------------------------------|
| Material   | red insulating material               |
| Mass       | approx. 1 g per coding pin            |
| Dimensions | 0.5 x 2 x 8 mm (0.02 x 0.08 x 0.3 in) |

Coding Pins

KF-CP

Features

- Coding of LB/FB-System terminal blocks
- Packaging unit: 20 x 6 coding pins

Function

The terminals can be coded with a coding pin by inserting the red tab into a particular slot of the terminal block.

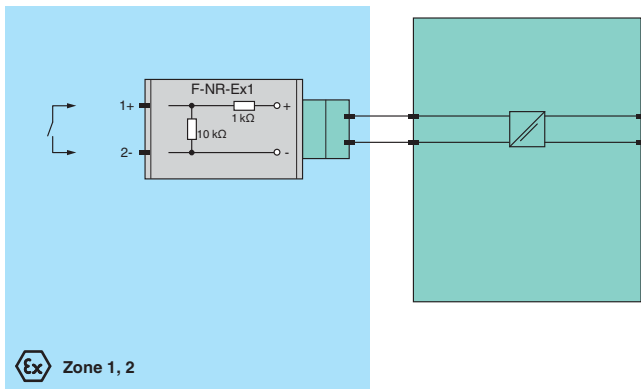

Ex Zone 1, 2

NAMUR Resistor Network

F-NR-Ex1

Features

- 1-channel
- Dry contact input
- For line fault detection (LFD)

Function

The NAMUR Resistor Network is used to monitor lead breakage and short circuit detection in switch amplifier circuits controlled by mechanical contacts. The component is installed directly to the control contact or inside its terminal box. The component can be used with all switch amplifiers featuring line fault detection.

Technical data

Supply

Rated voltage max. 20 V DC

Ambient conditions

Ambient temperature -20 ... 60 °C (-4 ... 140 °F)

Mechanical specifications

|                   |  |
|-------------------|--|
| Protection degree | IP20   |
| Connection        | screw terminals, wire cross section: ≤ 1.5 mm <sup>2</sup> |
| Mass              | approx. 20 g   |
| Dimensions        | Ø15.5 x 35 mm (0.61 x 1.38 in)                             |

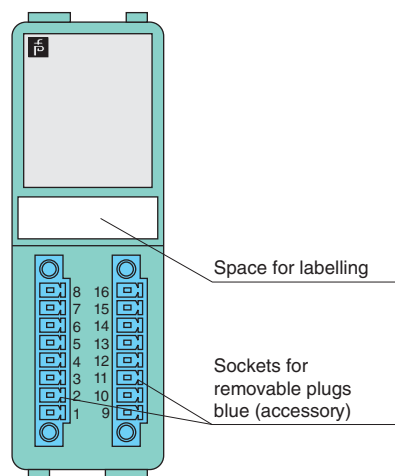

Dummy I/O Module

LB 9199 A

Features

- Marshalling for field and control side circuits
- On request

Technical data

Mechanical specifications

|            |                                       |
|------------|---------------------------------------|
| Dimensions | 32 x 100 x 103 mm (1.26 x 3.9 x 4 in) |
|------------|---------------------------------------|

Edition 912907 (US) / 220718 (EU) 06/2011



LB-System

Digital Inputs

Digital Outputs

Analog Inputs

Analog Outputs

Bus Couplers

Power Supplies

Accessories

LB-System

Digital Inputs

Digital Outputs

Analog Inputs

Analog Outputs

Bus Couplers

Power Supplies

Accessories

**Features**

- Max. 22 slots for I/O modules
- Installation in Zone 2 and Zone 22 or Class I, Div. 2 or safe area
- Redundancy (field bus and power supply)
- For PROFIBUS DP, PROFIBUS DP V1 and MODBUS RTU
- Backplane for LB-System

**Technical data**

**General specifications**

Suitable components backplane LB 9024 A

**Slots**

Bus coupler 2

Supply 3

I/O modules (single width) max. 22

I/O modules (dual width) max. 11

**Supply**

Rated voltage 24 V DC

Redundancy yes

**Fieldbus interface**

Fieldbus type PROFIBUS DP/PROFIBUS DP V1/MODBUS RTU, depends on bus coupler

Redundancy yes

**Mechanical specifications**

Protection degree IP20

Dimensions (W x H x D) 605 x 127 x 80 mm (23.8 x 5 x 3.15 in), without modules

**Data for application in connection with Ex-areas**

Declaration of conformity PF 08 CERT 1234

Group, category, type of protection, temperature classification Ex II 3G Ex nA IIC T4

**Directive conformity**

Directive 94/9/EC EN 60079-0:2006, EN 60079-15:2005

**International approvals**

IECEx approval BVS 09.0037X

**Diagrams**

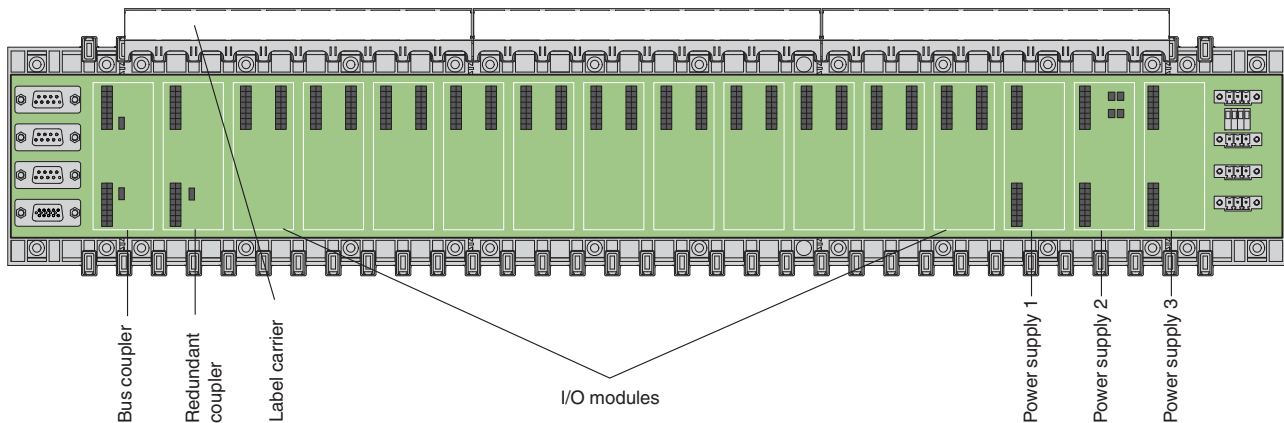

Edition 912907 (US) / 220718 (EU) 06/2011

| Technical data  |   |
|---|---|
| <b>General specifications</b>                                   |   |
| Suitable components   | backplane LB 9024 A   |
| <b>Slots</b>  |   |
| Bus coupler   | 2   |
| Supply  | 3   |
| I/O modules (single width)                                      | max. 22   |
| I/O modules (dual width)  | max. 11   |
| <b>Supply</b>   |   |
| Rated voltage   | 24 V DC   |
| Redundancy  | yes   |
| <b>Fieldbus interface</b>                                       |   |
| Fieldbus type   | MODBUS TCP/IP   |
| Redundancy  | yes   |
| <b>Mechanical specifications</b>                                |   |
| Protection degree   | IP20  |
| Dimensions  | (W x H x D) 605 x 127 x 80 mm (23.8 x 5 x 3.15 in), without modules |
| <b>Data for application in connection with Ex-areas</b>         |   |
| Declaration of conformity                                       | PF 08 CERT 1234   |
| Group, category, type of protection, temperature classification | Ⓜ II 3G Ex nA IIC T4  |
| <b>Directive conformity</b>                                     |   |
| Directive 94/9/EC   | EN 60079-0:2006, EN 60079-15:2005                                   |
| <b>International approvals</b>                                  |   |
| IECEx approval  | BVS 09.0037X  |

- Features**
- Max. 22 slots for I/O modules
  - Installation in Zone 2 and Zone 22 or Class I, Div. 2 or safe area
  - Redundancy (field bus and power supply)
  - For MODBUS TCP/IP
  - Backplane for LB-System

**Diagrams**

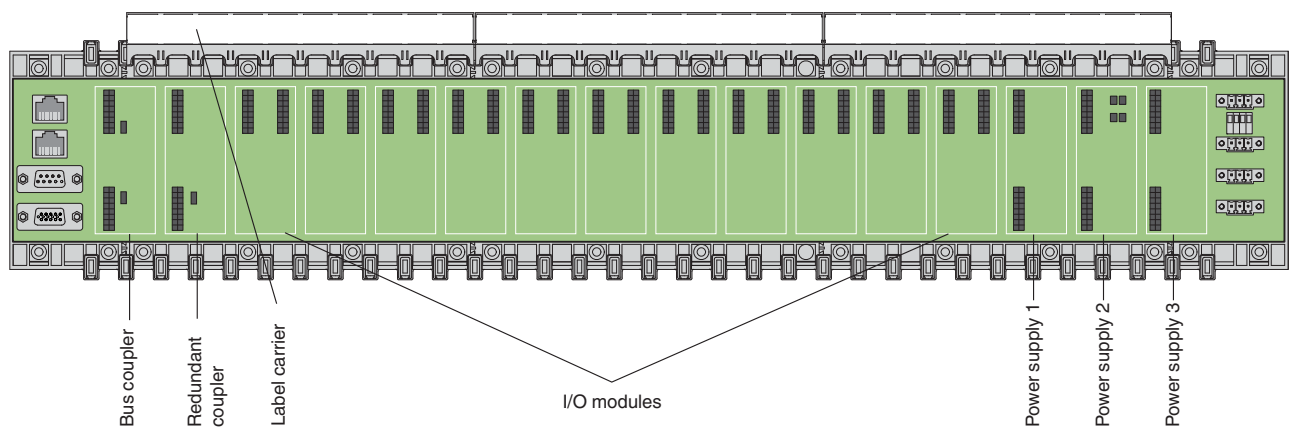

Edition 912907 (US) / 220718 (EU) 06/2011

Subject to modifications without notice

Pepperl+Fuchs Group  
www.pepperl-fuchs.com

USA: +1 330 486 0002  
pa-info@us.pepperl-fuchs.com

Germany: +49 621 776 2222  
pa-info@de.pepperl-fuchs.com

Copyright Pepperl+Fuchs  
Singapore: +65 6779 9091  
pa-info@sg.pepperl-fuchs.com



**Features**

- Max. 24 slots for I/O modules
- Installation in Zone 2 and Zone 22 or Class I, Div. 2 or safe area
- Redundancy (power supply)
- Fieldbus type determined by base backplane
- Backplane for LB-System

**Technical data**

**General specifications**

Suitable components backplane LB 9022 A, backplane LB 9022 E

**Slots**

Supply 3  
 I/O modules (single width) max. 24  
 I/O modules (dual width) max. 12

**Supply**

Rated voltage 24 V DC  
 Redundancy yes

**Fieldbus interface**

Fieldbus type see base backplane  
 Redundancy see base backplane LB 9022 \*

**Mechanical specifications**

Protection degree IP20  
 Dimensions (W x H x D) 605 x 127 x 80 mm (23.8 x 5 x 3.15 in), without modules

**Data for application in connection with Ex-areas**

Declaration of conformity PF 08 CERT 1234  
 Group, category, type of protection, temperature classification II 3G Ex nA IIC T4

Directive conformity  
 Directive 94/9/EC EN 60079-0:2006, EN 60079-15:2005

**International approvals**

IECEx approval BVS 09.0037X

**Diagrams**

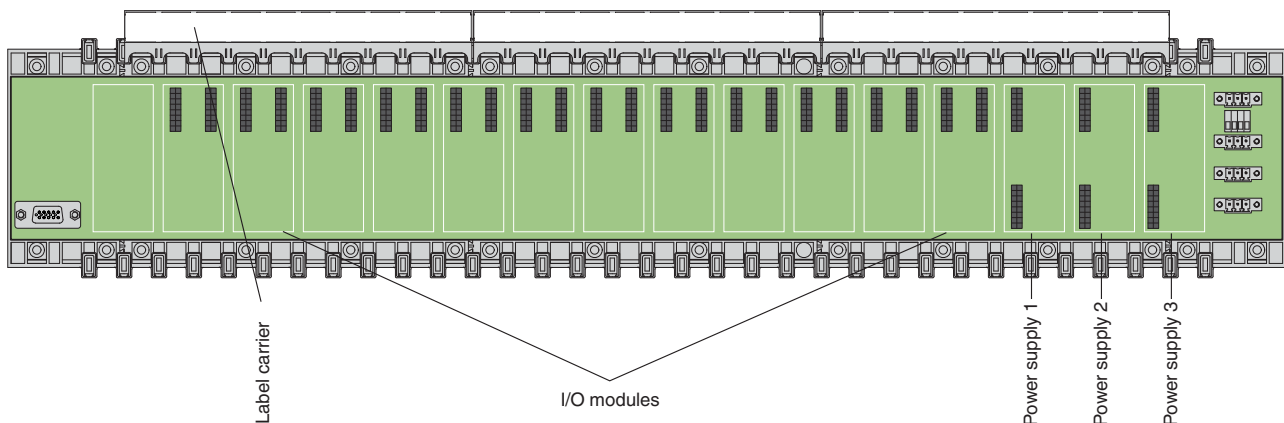

**Technical data**

|   |   |
|---|---|
| <b>General specifications</b>                                   |   |
| Suitable components   | backplane LB 9024 S   |
| <b>Slots</b>  |   |
| Bus coupler   | 2   |
| Supply  | 3   |
| I/O modules (single width)                                      | max. 22   |
| I/O modules (dual width)  | max. 11   |
| <b>Supply</b>   |   |
| Rated voltage   | 24 V DC   |
| Redundancy  | yes   |
| <b>Fieldbus interface</b>                                       |   |
| Fieldbus type   | PROFIBUS DP/PROFIBUS DP V1/MODBUS RTU, depends on bus coupler       |
| Redundancy  | yes   |
| <b>Mechanical specifications</b>                                |   |
| Protection degree   | IP20  |
| Dimensions  | (W x H x D) 605 x 127 x 80 mm (23.8 x 5 x 3.15 in), without modules |
| <b>Data for application in connection with Ex-areas</b>         |   |
| Declaration of conformity                                       | PF 08 CERT 1234   |
| Group, category, type of protection, temperature classification | ⊕ II 3G Ex nA IIC T4  |
| <b>Directive conformity</b>                                     |   |
| Directive 94/9/EC   | EN 60079-0:2006, EN 60079-15:2005                                   |
| <b>International approvals</b>                                  |   |
| IECEx approval  | BVS 09.0037X  |

**Features**

- Max. 22 slots for I/O modules
- 5 SIL2 output shutdown segments
- Installation in Zone 2 and Zone 22 or Class I, Div. 2 or safe area
- Redundancy (field bus and power supply)
- For PROFIBUS DP, PROFIBUS DP V1 and MODBUS RTU
- Backplane for LB-System



LB-System

Digital Inputs

Digital Outputs

Analog Inputs

Analog Outputs

Bus Couplers

Power Supplies

Accessories

**Diagrams**

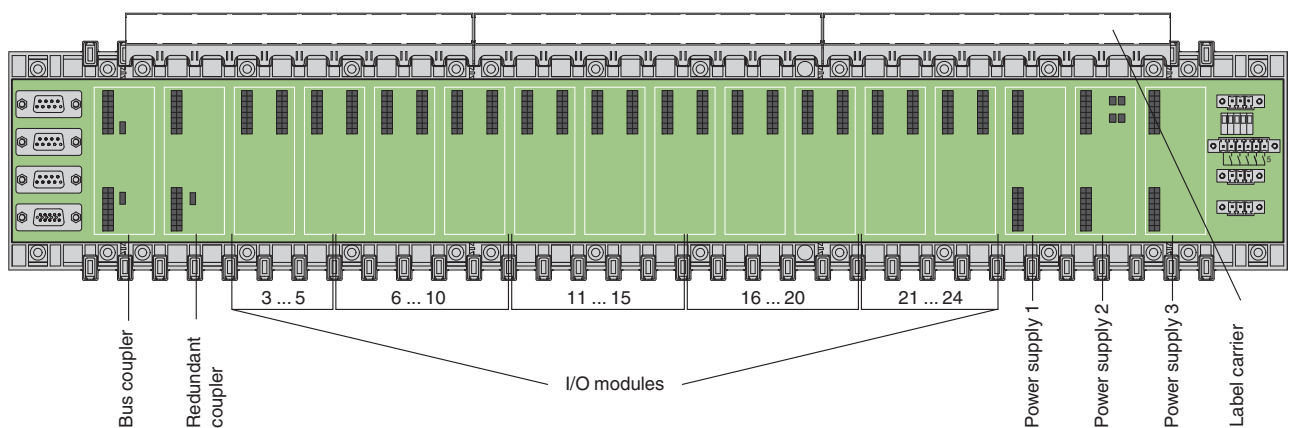

Edition 912907 (US) / 220718 (EU) 06/2011

Subject to modifications without notice

Pepperl+Fuchs Group  
www.pepperl-fuchs.com

USA: +1 330 486 0002  
pa-info@us.pepperl-fuchs.com

Germany: +49 621 776 2222  
pa-info@de.pepperl-fuchs.com

Copyright Pepperl+Fuchs  
Singapore: +65 6779 9091  
pa-info@sg.pepperl-fuchs.com

**Features**

- Max. 24 slots for I/O modules
- 5 SIL2 output shutdown segments
- Installation in Zone 2 and Zone 22 or Class I, Div. 2 or safe area
- Redundancy (power supply)
- Fieldbus type determined by base backplane
- Backplane for LB-System

**Technical data**

**General specifications**

Suitable components backplane LB 9022 A, backplane LB 9022 E, backplane LB 9022 S

**Slots**

Supply 3  
 I/O modules (single width) max. 24  
 I/O modules (dual width) max. 12

**Supply**

Rated voltage 24 V DC  
 Redundancy yes

**Fieldbus interface**

Fieldbus type see base backplane  
 Redundancy see base backplane LB 9022 \*

**Mechanical specifications**

Protection degree IP20  
 Dimensions (W x H x D) 605 x 127 x 80 mm (23.8 x 5 x 3.15 in), without modules

**Data for application in connection with Ex-areas**

Declaration of conformity PF 08 CERT 1234  
 Group, category, type of protection, temperature classification Ex II 3G Ex nA IIC T4  
 Directive conformity  
 Directive 94/9/EC EN 60079-0:2006, EN 60079-15:2005  
**International approvals**  
 IECEx approval BVS 09.0037X

**Diagrams**

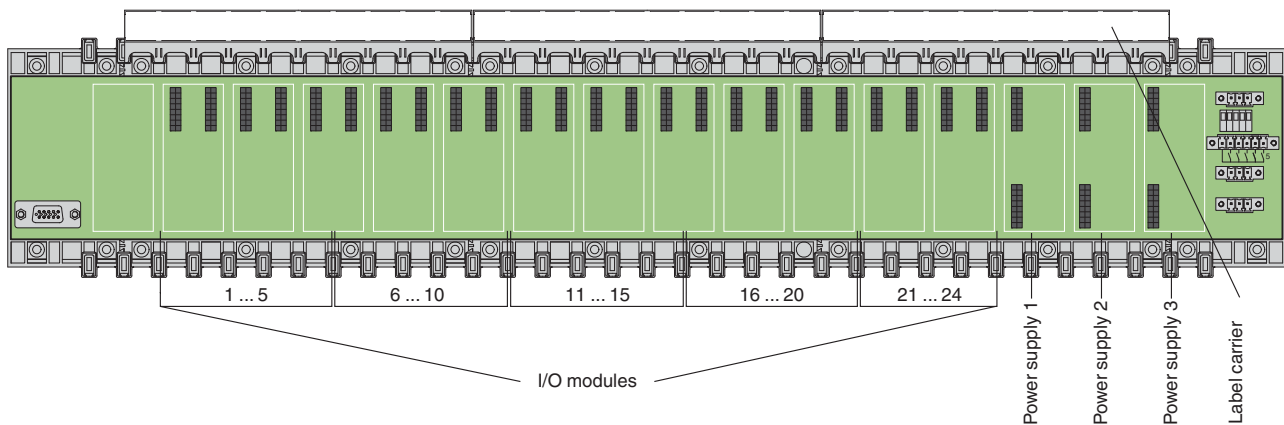

Edition 912907 (US) / 220718 (EU) 06/2011

| Technical data  |   |
|---|---|
| <b>General specifications</b>                                   |   |
| Suitable components   | backplane LB 9025 A   |
| <b>Slots</b>  |   |
| Bus coupler   | 1   |
| Supply  | 1   |
| I/O modules (single width)                                      | max. 8  |
| I/O modules (dual width)  | max. 4  |
| <b>Supply</b>   |   |
| Rated voltage   | 24 V DC   |
| Redundancy  | no  |
| <b>Fieldbus interface</b>                                       |   |
| Fieldbus type   | PROFIBUS DP/PROFIBUS DP V1/MODBUS RTU                               |
| Redundancy  | no  |
| <b>Mechanical specifications</b>                                |   |
| Protection degree   | IP20  |
| Dimensions  | (W x H x D) 275 x 127 x 80 mm (10.8 x 5 x 3.15 in), without modules |
| <b>Data for application in connection with Ex-areas</b>         |   |
| Declaration of conformity                                       | PF 08 CERT 1234   |
| Group, category, type of protection, temperature classification | Ⓜ II 3G Ex nA IIC T4  |
| <b>Directive conformity</b>                                     |   |
| Directive 94/9/EC   | EN 60079-0:2006, EN 60079-15:2005                                   |
| <b>International approvals</b>                                  |   |
| IECEX approval  | BVS 09.0037X  |

**Features**

- Max. 8 slots for I/O modules
- Installation in Zone 2 and Zone 22 or Class I, Div. 2 or safe area
- For PROFIBUS DP, PROFIBUS DP V1 and MODBUS RTU
- Backplane for LB-System

**Diagrams**

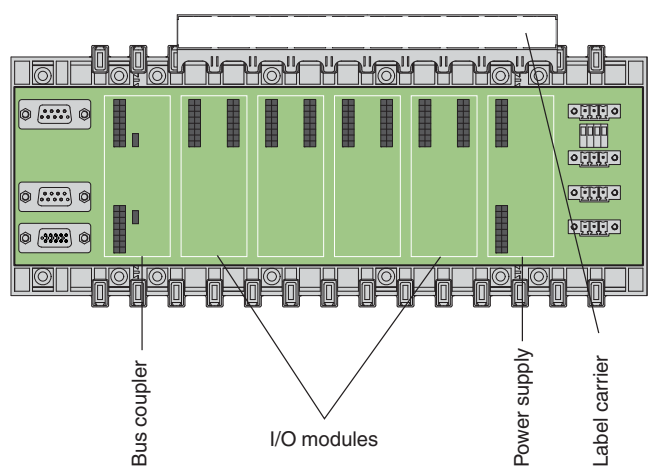

Edition 912907 (US) / 220718 (EU) 06/2011

LB-System

Digital Inputs

Digital Outputs

Analog Inputs

Analog Outputs

Bus Couplers

Power Supplies

Accessories

**Features**

- Max. 8 slots for I/O modules
- Installation in Zone 2 and Zone 22 or Class I, Div. 2 or safe area
- Fieldbus type determined by base backplane
- Backplane for LB-System

**Technical data**

**General specifications**

Suitable components backplane LB 9023 A

**Slots**

Supply 1

I/O modules (single width) max. 8

I/O modules (dual width) max. 4

**Supply**

Rated voltage 24 V DC

Redundancy no

**Fieldbus interface**

Fieldbus type see base backplane

Redundancy no

**Mechanical specifications**

Protection degree IP20

Dimensions (W x H x D) 275 x 127 x 80 mm (10.8 x 5 x 3.15 in), without modules

**Data for application in connection with Ex-areas**

Declaration of conformity PF 08 CERT 1234

Group, category, type of protection, temperature classification  II 3G Ex nA IIC T4

Directive conformity

Directive 94/9/EC EN 60079-0:2006, EN 60079-15:2005

**International approvals**

IECEx approval BVS 09.0037X

**Diagrams**

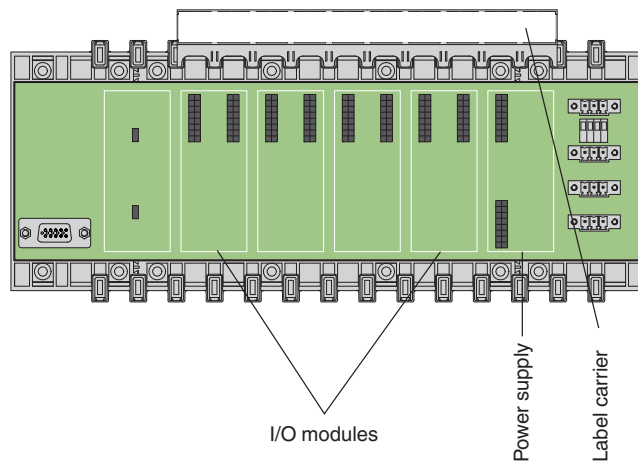

Edition 912907 (US) / 220718 (EU) 06/2011

**Technical data**

|   |   |
|---|---|
| <b>General specifications</b>                                   |   |
| Suitable components   | backplane LB 9027 A   |
| <b>Slots</b>  |   |
| Bus coupler   | 1   |
| Supply  | 2   |
| I/O modules (single width)                                      | max. 16   |
| I/O modules (dual width)  | max. 8  |
| <b>Supply</b>   |   |
| Rated voltage   | 24 V DC   |
| Redundancy  | no  |
| <b>Fieldbus interface</b>                                       |   |
| Fieldbus type   | PROFIBUS DP/PROFIBUS DP V1/MODBUS RTU, depends on bus coupler       |
| Redundancy  | no  |
| <b>Mechanical specifications</b>                                |   |
| Protection degree   | IP20  |
| Dimensions  | (W x H x D) 440 x 127 x 80 mm (17.3 x 5 x 3.15 in), without modules |
| <b>Data for application in connection with Ex-areas</b>         |   |
| Declaration of conformity                                       | PF 08 CERT 1234, observe statement of conformity                    |
| Group, category, type of protection, temperature classification | Ⓔ II 3G Ex nA IIC T4  |
| <b>Directive conformity</b>                                     |   |
| Directive 94/9/EC   | EN 60079-0:2006, EN 60079-15:2005                                   |
| <b>International approvals</b>                                  |   |
| IECEx approval  | BVS 09.0037X  |

**Features**

- Max. 16 slots for I/O modules
- Installation in Zone 2 and Zone 22 or Class I, Div. 2 or safe area
- For PROFIBUS DP, PROFIBUS DP V1 and MODBUS RTU
- Backplane for LB-System



LB-System

Digital Inputs

Digital Outputs

Analog Inputs

Analog Outputs

Bus Couplers

Power Supplies

Accessories

**Diagrams**

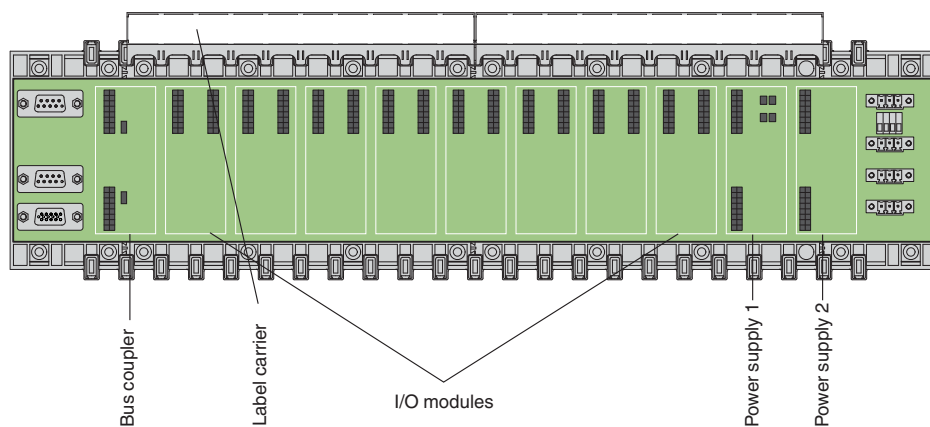

Edition 912907 (US) / 220718 (EU) 06/2011

Subject to modifications without notice

Pepperl+Fuchs Group  
www.pepperl-fuchs.com

USA: +1 330 486 0002  
pa-info@us.pepperl-fuchs.com

Germany: +49 621 776 2222  
pa-info@de.pepperl-fuchs.com

Copyright Pepperl+Fuchs  
Singapore: +65 6779 9091  
pa-info@sg.pepperl-fuchs.com

LB-System

Digital Inputs

Digital Outputs

Analog Inputs

Analog Outputs

Bus Couplers

Power Supplies

Accessories

**Features**

- Max. 16 slots for I/O modules
- Installation in Zone 2 and Zone 22 or Class I, Div. 2 or safe area
- Fieldbus type determined by base backplane
- Backplane for LB-System

**Technical data**

**General specifications**

Suitable components backplane LB 9026 \*

**Slots**

Supply 2

I/O modules (single width) max. 16

I/O modules (dual width) max. 8

**Supply**

Rated voltage 24 V DC

Redundancy no

**Fieldbus interface**

Fieldbus type see base backplane

Redundancy no

**Mechanical specifications**

Protection degree IP20

Dimensions (W x H x D) 440 x 127 x 80 mm (17.3 x 5 x 3.15 in), without modules

**Data for application in connection with Ex-areas**

Declaration of conformity PF 08 CERT 1234

Group, category, type of protection, temperature classification  $\text{Ex}$  II 3G Ex nA IIC T4

Directive conformity

Directive 94/9/EC EN 60079-0:2006, EN 60079-15:2005

**International approvals**

IECEx approval BVS 09.0037X

**Diagrams**

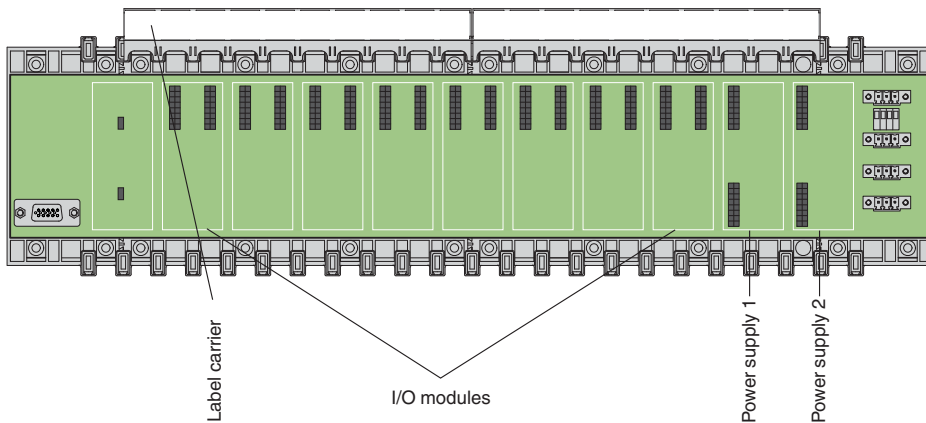

Edition 912907 (US) / 220718 (EU) 06/2011

| Technical data  |   |
|---|---|
| <b>Slots</b>  |   |
| Bus coupler   | 2   |
| Supply  | 3   |
| I/O modules (single width)                                      | max. 12   |
| I/O modules (dual width)  | max. 6  |
| <b>Supply</b>   |   |
| Rated voltage   | 24 V DC   |
| Redundancy  | yes   |
| <b>Fieldbus interface</b>                                       |   |
| Fieldbus type   | PROFIBUS DP/PROFIBUS DP V1/MODBUS RTU, depends on bus coupler       |
| Redundancy  | yes   |
| <b>Mechanical specifications</b>                                |   |
| Protection degree   | IP20  |
| Dimensions  | (W x H x D) 440 x 127 x 80 mm (17.3 x 5 x 3.15 in), without modules |
| <b>Data for application in connection with Ex-areas</b>         |   |
| Declaration of conformity                                       | PF 08 CERT 1234   |
| Group, category, type of protection, temperature classification | Ⓔ II 3G Ex nA IIC T4  |
| <b>Directive conformity</b>                                     |   |
| Directive 94/9/EC   | EN 60079-0:2006, EN 60079-15:2005                                   |
| <b>International approvals</b>                                  |   |
| IECEx approval  | BVS 09.0037X  |

Features

- Max. 12 slots for I/O modules
- Installation in Zone 2 and Zone 22 or Class I, Div. 2 or safe area
- Redundancy (field bus and power supply)
- For PROFIBUS DP, PROFIBUS DP V1 and MODBUS RTU
- Not extendable
- Backplane for LB-System

Diagrams

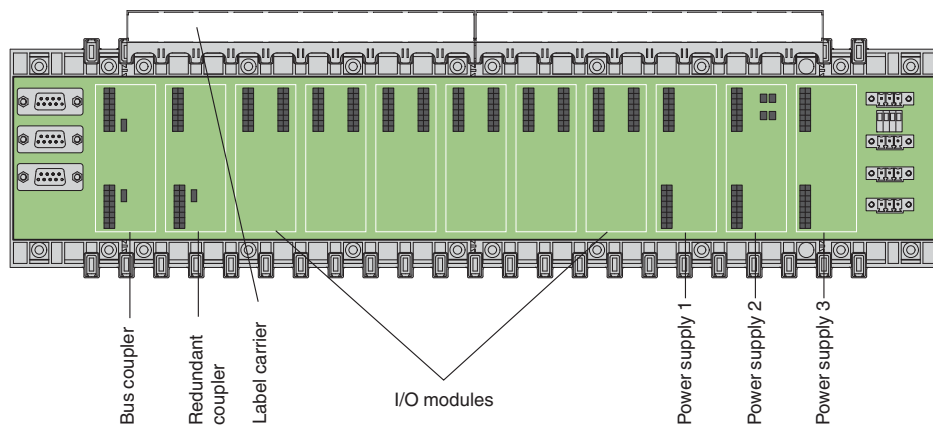

Edition 912907 (US) / 220718 (EU) 06/2011

Subject to modifications without notice

Pepperl+Fuchs Group  
www.pepperl-fuchs.com

USA: +1 330 486 0002  
pa-info@us.pepperl-fuchs.com

Germany: +49 621 776 2222  
pa-info@de.pepperl-fuchs.com

Copyright Pepperl+Fuchs  
Singapore: +65 6779 9091  
pa-info@sg.pepperl-fuchs.com



LB-System

Digital Inputs

Digital Outputs

Analog Inputs

Analog Outputs

Bus Couplers

Power Supplies

Accessories

**Features**

- Max. 5 slots for I/O modules (dual width only)
- Installation in Zone 2 and Zone 22 or Class I, Div. 2 or safe area
- For FOUNDATION fieldbus H1
- Backplane for LB-System

**Technical data**

|   |   |
|---|---|
| <b>Slots</b>  |   |
| Bus coupler   | 1   |
| Supply  | 1   |
| I/O modules (dual width)  | max. 5  |
| <b>Supply</b>   |   |
| Rated voltage   | 24 V DC   |
| Redundancy  | no  |
| <b>Fieldbus interface</b>                                       |   |
| Fieldbus type   | FOUNDATION fieldbus H1  |
| Redundancy  | no  |
| <b>Mechanical specifications</b>                                |   |
| Protection degree   | IP20  |
| Dimensions  | (W x H x D) 275 x 127 x 80 mm (10.8 x 5 x 3.15 in), without modules |
| <b>Data for application in connection with Ex-areas</b>         |   |
| Declaration of conformity                                       | PF 08 CERT 1234   |
| Group, category, type of protection, temperature classification | Ex II 3G Ex nA IIC T4   |
| Directive conformity  |   |
| Directive 94/9/EC   | EN 60079-0:2006, EN 60079-15:2005                                   |
| <b>International approvals</b>                                  |   |
| IECEx approval  | BVS 09.0037X  |

**Diagrams**

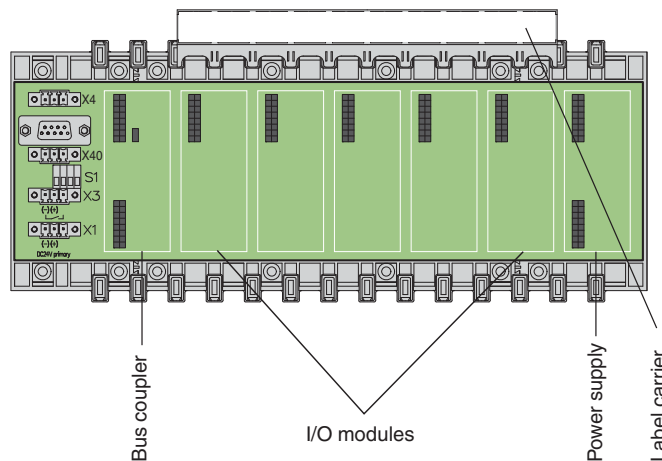

Edition 912907 (US) / 220718 (EU) 06/2011

**Technical data**

**Mechanical specifications**

|                   |   |
|-------------------|---|
| Dimensions        | (W x H x D) 350 x 306 x 215 mm (13.8 x 12 x 8.5 in) |
| Material          |   |
| Housing           | stainless steel 1.4404/AISI 316L                    |
| Surface           | electropolished                                     |
| Cable gland       | Polyamide (PA)                                      |
| Protection degree | IP66, NEMA 4x                                       |
| Mass              | approx. 10 kg, without modules                      |
| Mounting          | clearance holes Ø11 mm                              |
| Grounding         | grounding bolt M10, brass                           |

**Ambient conditions**

|                     |   |
|---------------------|---|
| Ambient temperature | -20 ... 55 °C (-4 ... 131 °F) at T4, depending on the permissible power |
| Storage temperature | -40 ... 70 °C (-40 ... 158 °F)  |

**General specifications**

|                      |                     |
|----------------------|---------------------|
| Installed components | backplane LB 9023 A |
|----------------------|---------------------|

**Slots**

|                            |        |
|----------------------------|--------|
| Bus coupler                | 1      |
| Supply                     | 1      |
| I/O modules (single width) | max. 8 |
| I/O modules (dual width)   | max. 4 |

**Supply**

|               |  |
|---------------|--|
| Connection    | screw terminals, max. 10 mm <sup>2</sup> |
| Rated voltage | 24 V DC                                  |
| Redundancy    | no                                       |

**Fieldbus interface**

|            |  |
|------------|--|
| Connection | 9-pin Sub-D connector (not included with delivery) |
| Redundancy | no   |

**Data for application in connection with Ex-areas**

|   |  |
|---|--|
| EC-Type Examination Certificate                                 | PTB 03 ATEX 2042   |
| Group, category, type of protection                             | <ul style="list-style-type: none"> <li>⊕ II (1) G [Ex ia] IIC/IIB</li> <li>⊕ II (2) G [Ex ib] IIC</li> <li>⊕ II (1) D [Ex ia D]</li> <li>⊕ II (2) D [Ex ib D]</li> </ul>   |
| Declaration of conformity                                       | PF 08 CERT 1267  |
| Group, category, type of protection, temperature classification | <ul style="list-style-type: none"> <li>⊕ II 3 G Ex nA nC [ic] IIC/IIB T4</li> <li>⊕ II 3 (2) G Ex nA nC [ib] IIC T4</li> <li>⊕ II 3 (1) G Ex nA nC [ia] IIC/IIB T4</li> <li>⊕ II 3 D Ex tD A22 IP65 T 130°C</li> <li>⊕ II (2) D [Ex ib] IIC</li> <li>⊕ II (1) D [Ex ia] IIC</li> </ul> |

**Features**

- Max. 8 slots for I/O modules
- Installation in Zone 2 and Zone 22 or Class I, Div. 2 or safe area
- Electropolished enclosure, IP66/NEMA 4x
- For PROFIBUS DP, PROFIBUS DP V1 and MODBUS RTU
- Packaged certified solution
- Standard enclosure for LB-System

**Function**

This field unit is designed to meet the requirements of the most demanding industrial environmental applications. Electropolished stainless steel 316L provides high corrosion resistance for both onshore and offshore installations. The one piece seal is protected from standing water damage by the box's integral rain channel. It is equipped with plug-in slots for 4 dual width I/O modules or 8 single width I/O modules. Any I/O module can be inserted into any slot, enabling a mixture of I/O types in one field unit.

**Diagrams**

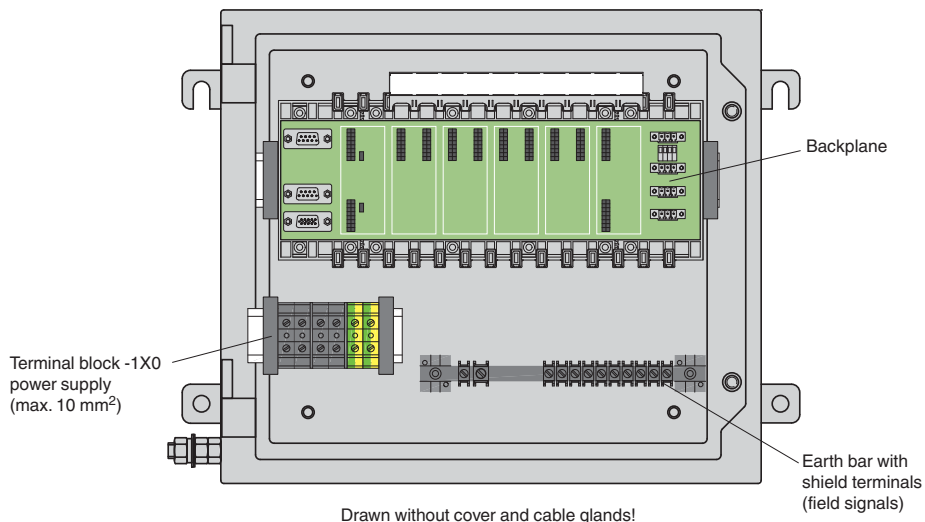

Edition 912907 (US) / 220718 (EU) 06/2011

Subject to modifications without notice

Pepperl+Fuchs Group  
www.pepperl-fuchs.com

USA: +1 330 486 0002  
pa-info@us.pepperl-fuchs.com

Germany: +49 621 776 2222  
pa-info@de.pepperl-fuchs.com

Copyright Pepperl+Fuchs  
Singapore: +65 6779 9091  
pa-info@sg.pepperl-fuchs.com



LB-System

Digital Inputs

Digital Outputs

Analog Inputs

Analog Outputs

Bus Couplers

Power Supplies

Accessories

LB-System  
Digital Inputs  
Digital Outputs  
Analog Inputs  
Analog Outputs  
Bus Couplers  
Power Supplies  
Accessories

**Features**

- Max. 5 slots for I/O modules (dual width only)
- Installation in Zone 2 and Zone 22 or Class I, Div. 2 or safe area
- Electropolished enclosure, IP66/NEMA 4x
- For FOUNDATION fieldbus H1
- Packaged certified solution
- Standard enclosure for LB-System

**Function**

This field unit is designed to meet the requirements of the most demanding industrial environmental applications.

Electropolished stainless steel 316L provides high corrosion resistance for both onshore and offshore installations. The one piece seal is protected from standing water damage by the box's integral rain channel.

It is equipped with plug-in slots for 5 dual width I/O modules.

Any I/O module can be inserted into any slot, enabling a mixture of I/O types in one field unit.

**Technical data**

**Mechanical specifications**

|                   |   |
|-------------------|---|
| Dimensions        | (W x H x D) 350 x 306 x 215 mm (13.8 x 12 x 8.5 in) |
| Material          |   |
| Housing           | stainless steel 1.4404/AISI 316L                    |
| Surface           | electropolished                                     |
| Cable gland       | Polyamide (PA)                                      |
| Protection degree | IP66, NEMA 4x                                       |
| Mass              | approx. 10 kg, without modules                      |
| Mounting          | clearance holes Ø11 mm                              |
| Grounding         | grounding bolt M10, brass                           |

**Ambient conditions**

|                     |   |
|---------------------|---|
| Ambient temperature | -20 ... 55 °C (-4 ... 131 °F) at T4, depending on the permissible power |
| Storage temperature | -40 ... 70 °C (-40 ... 158 °F)  |

**General specifications**

|                      |                     |
|----------------------|---------------------|
| Installed components | backplane LB 9035 A |
|----------------------|---------------------|

**Slots**

|                          |        |
|--------------------------|--------|
| Bus coupler              | 1      |
| Supply                   | 1      |
| I/O modules (dual width) | max. 5 |

**Supply**

|               |  |
|---------------|--|
| Connection    | screw terminals, max. 10 mm <sup>2</sup> |
| Rated voltage | 24 V DC                                  |
| Redundancy    | no                                       |

**Fieldbus interface**

|            |  |
|------------|--|
| Connection | wire clamp terminals, max. 2.5 mm <sup>2</sup> |
| Redundancy | no   |

**Data for application in connection with Ex-areas**

|                                     |  |
|-------------------------------------|--|
| EC-Type Examination Certificate     | PTB 03 ATEX 2042   |
| Group, category, type of protection | ⊗ II (1) G [Ex ia] IIC/IIB<br>⊗ II (2) G [Ex ib] IIC<br>⊗ II (1) D [Ex ia D]<br>⊗ II (2) D [Ex ib D] |

**Declaration of conformity**

|   |  |
|---|--|
| Group, category, type of protection, temperature classification | ⊗ II 3 G Ex nA nC [ic] IIC/IIB T4<br>⊗ II 3 (2) G Ex nA nC [ib] IIC T4<br>⊗ II 3 (1) G Ex nA nC [ia] IIC/IIB T4<br>⊗ II 3 D Ex tD A22 IP65 T 130°C<br>⊗ II (2) D [Ex ib] IIIC<br>⊗ II (1) D [Ex ia] IIIC |
|---|--|

**Diagrams**

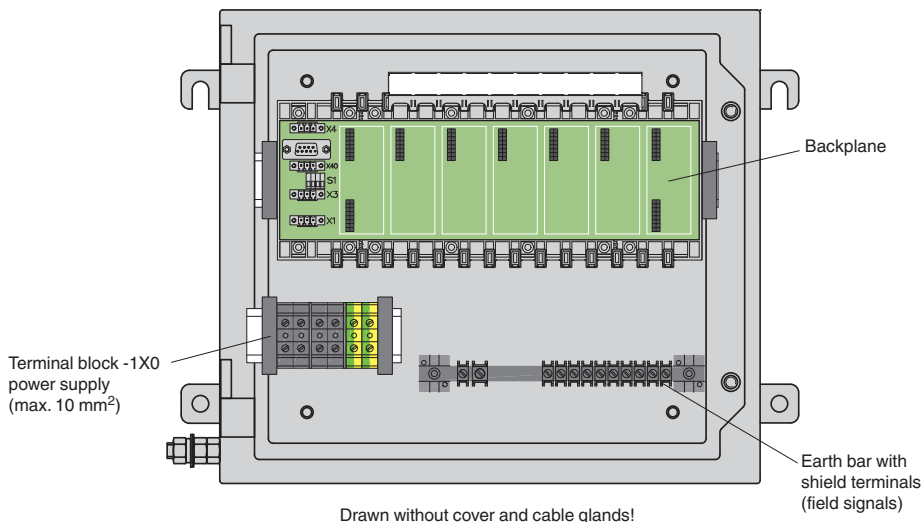

Drawn without cover and cable glands!

Edition 912907 (US) / 220718 (EU) 06/2011

**Technical data**

**Mechanical specifications**

|                   |   |
|-------------------|---|
| Dimensions        | (W x H x D) 544 x 271 x 210 mm (21.4 x 10.7 x 8.3 in) |
| Material          |   |
| Housing           | polyester, impact resistant, glass fiber reinforced   |
| Surface           | black molded finish (RAL 9005)                        |
| Cable gland       | Polyamide (PA)  |
| Protection degree | IP66, NEMA 4x   |
| Mass              | approx. 10 kg, without modules                        |
| Mounting          | clearance holes Ø6.5 mm                               |

**Ambient conditions**

|                     |   |
|---------------------|---|
| Ambient temperature | -20 ... 55 °C (-4 ... 131 °F) at T4, depending on the permissible power |
| Storage temperature | -40 ... 70 °C (-40 ... 158 °F)  |

**General specifications**

|                      |                     |
|----------------------|---------------------|
| Installed components | backplane LB 9029 A |
|----------------------|---------------------|

**Slots**

|                            |         |
|----------------------------|---------|
| Bus coupler                | 2       |
| Supply                     | 3       |
| I/O modules (single width) | max. 12 |
| I/O modules (dual width)   | max. 6  |

**Supply**

|               |  |
|---------------|--|
| Connection    | screw terminals, max. 10 mm <sup>2</sup> |
| Rated voltage | 24 V DC                                  |
| Redundancy    | yes                                      |

**Fieldbus interface**

|            |  |
|------------|--|
| Connection | 9-pin Sub-D connector (not included with delivery) |
| Redundancy | yes  |

**Data for application in connection with Ex-areas**

|                                     |  |
|-------------------------------------|--|
| EC-Type Examination Certificate     | PTB 03 ATEX 2042   |
| Group, category, type of protection | ⓧ II (1) G [Ex ia] IIC/IIB<br>ⓧ II (2) G [Ex ib] IIC<br>ⓧ II (1) D [Ex ia D]<br>ⓧ II (2) D [Ex ib D] |

**Declaration of conformity**

|   |  |
|---|--|
| Group, category, type of protection, temperature classification | ⓧ II 3 G Ex nA nC [ic] IIC/IIB T4<br>ⓧ II 3 (2) G Ex nA nC [ib] IIC T4<br>ⓧ II 3 (1) G Ex nA nC [ia] IIC/IIB T4<br>ⓧ II 3 D Ex tD A22 IP65 T 130°C<br>ⓧ II (2) D [Ex ib] IIIC<br>ⓧ II (1) D [Ex ia] IIIC |
|---|--|

**Features**

- Max. 12 slots for I/O modules
- Installation in Zone 2 and Zone 22 or Class I, Div. 2 or safe area
- Impact resistance enclosure, IP66/NEMA 4x
- Redundancy (field bus and power supply)
- For PROFIBUS DP, PROFIBUS DP V1 and MODBUS RTU
- Packaged certified solution
- Standard enclosure for LB-System

**Function**

This field unit is designed to meet the requirements of the most demanding industrial environmental applications. Glass-fiber reinforced polyester provides high corrosion resistance for both onshore and offshore installations. Electrostatic charge is avoided by suitable surface resistance.

It is equipped with plug-in slots for 6 dual width I/O modules or 12 single width I/O modules.

Any I/O module can be inserted into any slot, enabling a mixture of I/O types in one field unit.

The fieldbus and power supply are equipped with redundant connections.

**Diagrams**

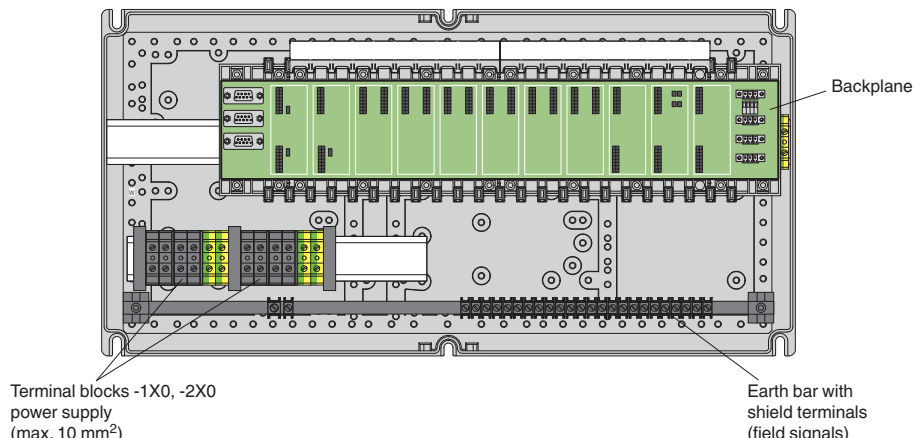

Drawn without cover and cable glands!

Edition 912907 (US) / 220718 (EU) 06/2011

Subject to modifications without notice

Pepperl+Fuchs Group  
www.pepperl-fuchs.com

USA: +1 330 486 0002  
pa-info@us.pepperl-fuchs.com

Germany: +49 621 776 2222  
pa-info@de.pepperl-fuchs.com

Copyright Pepperl+Fuchs  
Singapore: +65 6779 9091  
pa-info@sg.pepperl-fuchs.com



LB-System

Digital Inputs

Digital Outputs

Analog Inputs

Analog Outputs

Bus Couplers

Power Supplies

Accessories



LB-System

Digital Inputs

Digital Outputs

Analog Inputs

Analog Outputs

Bus Couplers

Power Supplies

Accessories

**Features**

- Max. 16 slots for I/O modules
- Installation in Zone 2 and Zone 22 or Class I, Div. 2 or safe area
- Impact resistance enclosure, IP66/NEMA 4x
- For PROFIBUS DP, PROFIBUS DP V1 and MODBUS RTU
- Packaged certified solution
- Standard enclosure for LB-System

**Function**

This field unit is designed to meet the requirements of the most demanding industrial environmental applications.

Glass-fiber reinforced polyester provides high corrosion resistance for both onshore and offshore installations. Electrostatic charge is avoided by suitable surface resistance.

It is equipped with plug-in slots for 8 dual width I/O modules or 16 single width I/O modules.

Any I/O module can be inserted into any slot, enabling a mixture of I/O types in one field unit.

**Technical data**

**Mechanical specifications**

|                   |   |
|-------------------|---|
| Dimensions        | (W x H x D) 544 x 271 x 210 mm (21.4 x 10.7 x 8.3 in) |
| Material          |   |
| Housing           | polyester, impact resistant, glass fiber reinforced   |
| Surface           | black molded finish (RAL 9005)                        |
| Cable gland       | Polyamide (PA)  |
| Protection degree | IP66, NEMA 4x   |
| Mass              | approx. 10 kg, without modules                        |
| Mounting          | clearance holes Ø6.5 mm                               |

**Ambient conditions**

|                     |   |
|---------------------|---|
| Ambient temperature | -20 ... 55 °C (-4 ... 131 °F) at T4, depending on the permissible power |
| Storage temperature | -40 ... 70 °C (-40 ... 158 °F)  |

**General specifications**

|                      |                     |
|----------------------|---------------------|
| Installed components | backplane LB 9026 A |
|----------------------|---------------------|

**Slots**

|                            |         |
|----------------------------|---------|
| Bus coupler                | 1       |
| Supply                     | 2       |
| I/O modules (single width) | max. 16 |
| I/O modules (dual width)   | max. 8  |

**Supply**

|               |  |
|---------------|--|
| Connection    | screw terminals, max. 10 mm <sup>2</sup> |
| Rated voltage | 24 V DC                                  |
| Redundancy    | no                                       |

**Fieldbus interface**

|            |  |
|------------|--|
| Connection | 9-pin Sub-D connector (not included with delivery) |
| Redundancy | no   |

**Data for application in connection with Ex-areas**

|                                     |  |
|-------------------------------------|--|
| EC-Type Examination Certificate     | PTB 03 ATEX 2042   |
| Group, category, type of protection | ⓧ II (1) G [Ex ia] IIC/IIB<br>ⓧ II (2) G [Ex ib] IIC<br>ⓧ II (1) D [Ex ia D]<br>ⓧ II (2) D [Ex ib D] |

**Declaration of conformity**

|   |  |
|---|--|
| Group, category, type of protection, temperature classification | ⓧ II 3 G Ex nA nC [ic] IIC/IIB T4<br>ⓧ II 3 (2) G Ex nA nC [ib] IIC T4<br>ⓧ II 3 (1) G Ex nA nC [ia] IIC/IIB T4<br>ⓧ II 3 D Ex tD A22 IP65 T 130°C<br>ⓧ II (2) D [Ex ib] IIIC<br>ⓧ II (1) D [Ex ia] IIIC |
|---|--|

**Diagrams**

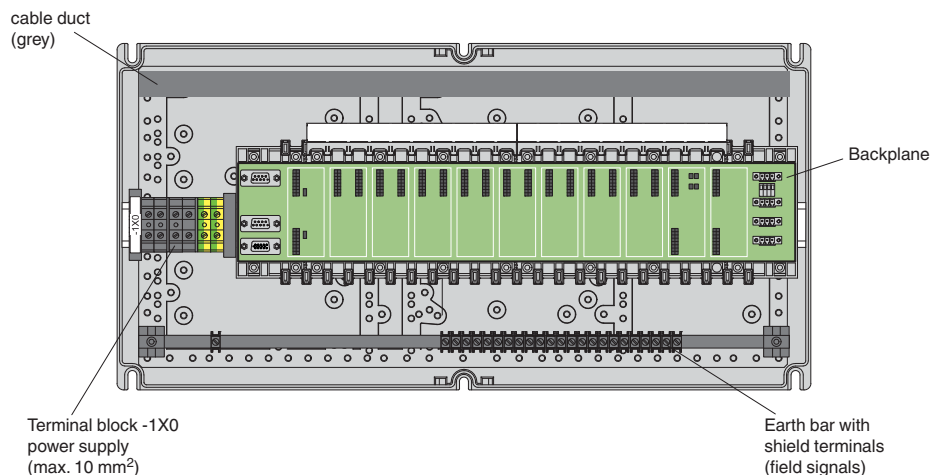

Drawn without cover and cable glands!

Edition 912907 (US) / 220718 (EU) 06/2011

**Technical data**

**Mechanical specifications**

|                   |  |
|-------------------|--|
| Dimensions        | (W x H x D) 800 x 800 x 300 mm (31.5 x 31.5 x 11.8 in) |
| Material          |  |
| Housing           | stainless steel 1.4404/AISI 316L                       |
| Surface           | electropolished  |
| Cable gland       | Polyamide (PA)   |
| Protection degree | IP66, NEMA 4x  |
| Mass              | approx. 35 kg, without modules                         |
| Mounting          | clearance holes Ø11 mm                                 |
| Grounding         | grounding bolt M10, brass                              |

**Ambient conditions**

|                     |   |
|---------------------|---|
| Ambient temperature | -20 ... 55 °C (-4 ... 131 °F) at T4, depending on the permissible power |
| Storage temperature | -40 ... 70 °C (-40 ... 158 °F)  |

**General specifications**

|                      |  |
|----------------------|--|
| Installed components | backplane LB 9022 E, backplane LB 9024 A |
|----------------------|--|

**Slots**

|                            |         |
|----------------------------|---------|
| Bus coupler                | 2       |
| Supply                     | 6       |
| I/O modules (single width) | max. 46 |
| I/O modules (dual width)   | max. 23 |

**Supply**

|               |  |
|---------------|--|
| Connection    | screw terminals, max. 10 mm <sup>2</sup> |
| Rated voltage | 24 V DC                                  |
| Redundancy    | yes                                      |

**Fieldbus interface**

|            |   |
|------------|---|
| Connection | RJ45 connector (not included with delivery) |
| Redundancy | yes   |

**Data for application in connection with Ex-areas**

|   |  |
|---|--|
| EC-Type Examination Certificate                                 | PTB 03 ATEX 2042   |
| Group, category, type of protection                             | ⓧ II (1) G [Ex ia] IIC/IIB<br>ⓧ II (2) G [Ex ib] IIC<br>ⓧ II (1) D [Ex ia D]<br>ⓧ II (2) D [Ex ib D]   |
| Declaration of conformity                                       | PF 08 CERT 1267  |
| Group, category, type of protection, temperature classification | ⓧ II 3 G Ex nA nC [ic] IIC/IIB T4<br>ⓧ II 3 (2) G Ex nA nC [ib] IIC T4<br>ⓧ II 3 (1) G Ex nA nC [ia] IIC/IIB T4<br>ⓧ II 3 D Ex tD A22 IP65 T 130°C<br>ⓧ II (2) D [Ex ib] IIC<br>ⓧ II (1) D [Ex ia] IIC |

**Features**

- Max. 46 slots for I/O modules
- Installation in Zone 2 and Zone 22 or Class I, Div. 2 or safe area
- Electropolished enclosure, IP66/NEMA 4x
- Redundancy (field bus and power supply)
- For MODBUS TCP/IP
- Packaged certified solution
- Standard enclosure for LB-System

**Function**

This field unit is designed to meet the requirements of the most demanding industrial environmental applications. Electropolished stainless steel 316L provides high corrosion resistance for both onshore and offshore installations. The one piece seal is protected from standing water damage by the box's integral rain channel. It is equipped with plug-in slots for 23 dual width I/O modules or 46 single width I/O modules. Any I/O module can be inserted into any slot, enabling a mixture of I/O types in one field unit. The fieldbus and power supply are equipped with redundant connections.

**Diagrams**

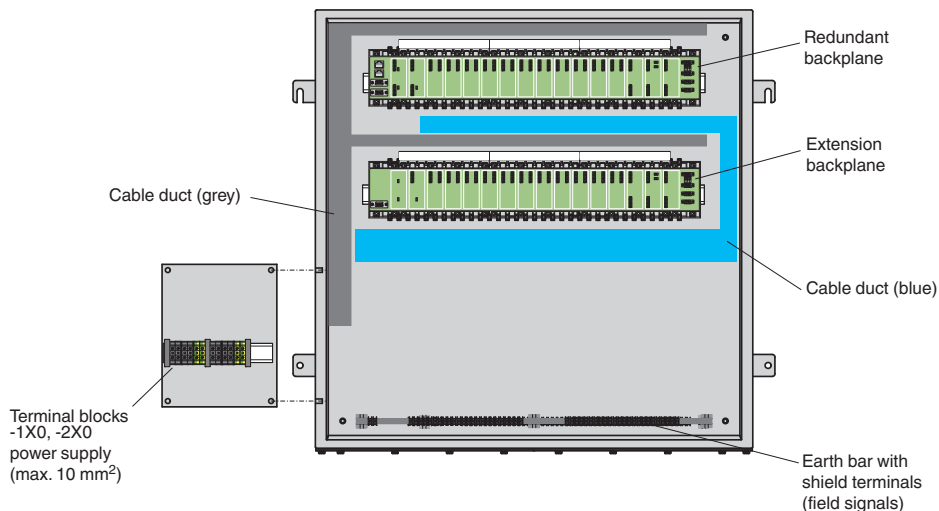

Edition 912907 (US) / 220718 (EU) 06/2011

Subject to modifications without notice

Pepperl+Fuchs Group  
www.pepperl-fuchs.com

USA: +1 330 486 0002  
pa-info@us.pepperl-fuchs.com

Germany: +49 621 776 2222  
pa-info@de.pepperl-fuchs.com

Copyright Pepperl+Fuchs  
Singapore: +65 6779 9091  
pa-info@sg.pepperl-fuchs.com



LB-System

Digital Inputs

Digital Outputs

Analog Inputs

Analog Outputs

Bus Couplers

Power Supplies

Accessories



LB-System

Digital Inputs

Digital Outputs

Analog Inputs

Analog Outputs

Bus Couplers

Power Supplies

Accessories

**Features**

- Max. 46 slots for I/O modules
- Installation in Zone 2 and Zone 22 or Class I, Div. 2 or safe area
- Electropolished enclosure, IP66/NEMA 4x
- Redundancy (field bus and power supply)
- For PROFIBUS DP, PROFIBUS DP V1 and MODBUS RTU
- Packaged certified solution
- Standard enclosure for LB-System

**Function**

This field unit is designed to meet the requirements of the most demanding industrial environmental applications.

Electropolished stainless steel 316L provides high corrosion resistance for both onshore and offshore installations. The one piece seal is protected from standing water damage by the box's integral rain channel.

It is equipped with plug-in slots for 23 dual width I/O modules or 46 single width I/O modules.

Any I/O module can be inserted into any slot, enabling a mixture of I/O types in one field unit.

The fieldbus and power supply are equipped with redundant connections.

**Technical data**

**Mechanical specifications**

|                           |   |
|---------------------------|---|
| Dimensions                | (W x H x D) 800 x 800 x 300 mm (31.5 x 31.5 x 11.8 in)                  |
| Material                  |   |
| Housing                   | stainless steel 1.4404/AISI 316L  |
| Surface                   | electropolished   |
| Cable gland               | Polyamide (PA)  |
| Protection degree         | IP66, NEMA 4x   |
| Mass                      | approx. 35 kg, without modules  |
| Mounting                  | clearance holes Ø11 mm  |
| Grounding                 | grounding bolt M10, brass   |
| <b>Ambient conditions</b> |   |
| Ambient temperature       | -20 ... 55 °C (-4 ... 131 °F) at T4, depending on the permissible power |
| Storage temperature       | -40 ... 70 °C (-40 ... 158 °F)  |

**General specifications**

|                      |  |
|----------------------|--|
| Installed components | backplane LB 9022 A, backplane LB 9024 A |
|----------------------|--|

**Slots**

|                            |         |
|----------------------------|---------|
| Bus coupler                | 2       |
| Supply                     | 6       |
| I/O modules (single width) | max. 46 |
| I/O modules (dual width)   | max. 23 |

**Supply**

|               |  |
|---------------|--|
| Connection    | screw terminals, max. 10 mm <sup>2</sup> |
| Rated voltage | 24 V DC                                  |
| Redundancy    | yes                                      |

**Fieldbus interface**

|            |  |
|------------|--|
| Connection | 9-pin Sub-D connector (not included with delivery) |
| Redundancy | yes  |

**Data for application in connection with Ex-areas**

|   |  |
|---|--|
| EC-Type Examination Certificate                                 | PTB 03 ATEX 2042   |
| Group, category, type of protection                             | <ul style="list-style-type: none"> <li>⊗ II (1) G [Ex ia] IIC/IIB</li> <li>⊗ II (2) G [Ex ib] IIC</li> <li>⊗ II (1) D [Ex ia D]</li> <li>⊗ II (2) D [Ex ib D]</li> </ul>   |
| Declaration of conformity                                       | PF 08 CERT 1267  |
| Group, category, type of protection, temperature classification | <ul style="list-style-type: none"> <li>⊗ II 3 G Ex nA nC [ic] IIC/IIB T4</li> <li>⊗ II 3 (2) G Ex nA nC [ib] IIC T4</li> <li>⊗ II 3 (1) G Ex nA nC [ia] IIC/IIB T4</li> <li>⊗ II 3 D Ex tD A22 IP65 T 130°C</li> <li>⊗ II (2) D [Ex ib] IIIC</li> <li>⊗ II (1) D [Ex ia] IIIC</li> </ul> |

**Diagrams**

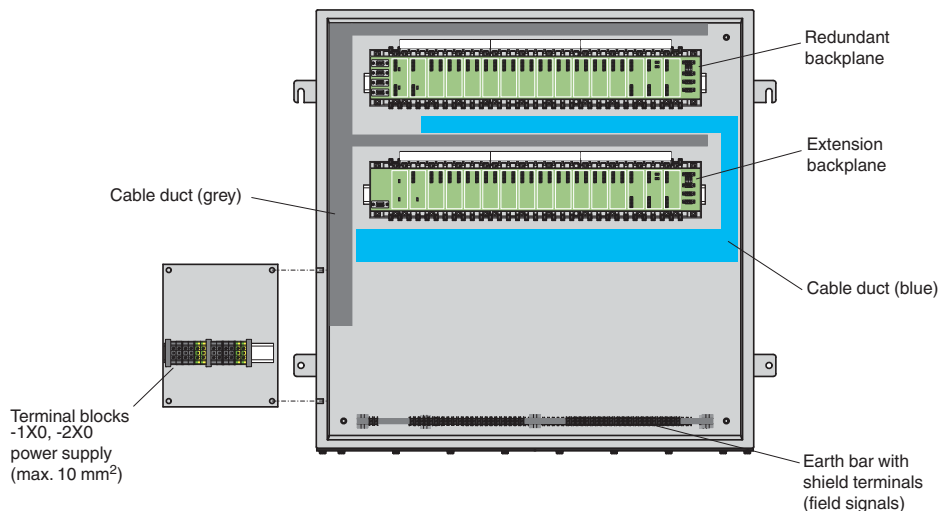

Edition 912907 (US) / 220718 (EU) 06/2011



LB-System

Digital Inputs

Digital Outputs

Analog Inputs

Analog Outputs

Bus Couplers

Power Supplies

Accessories

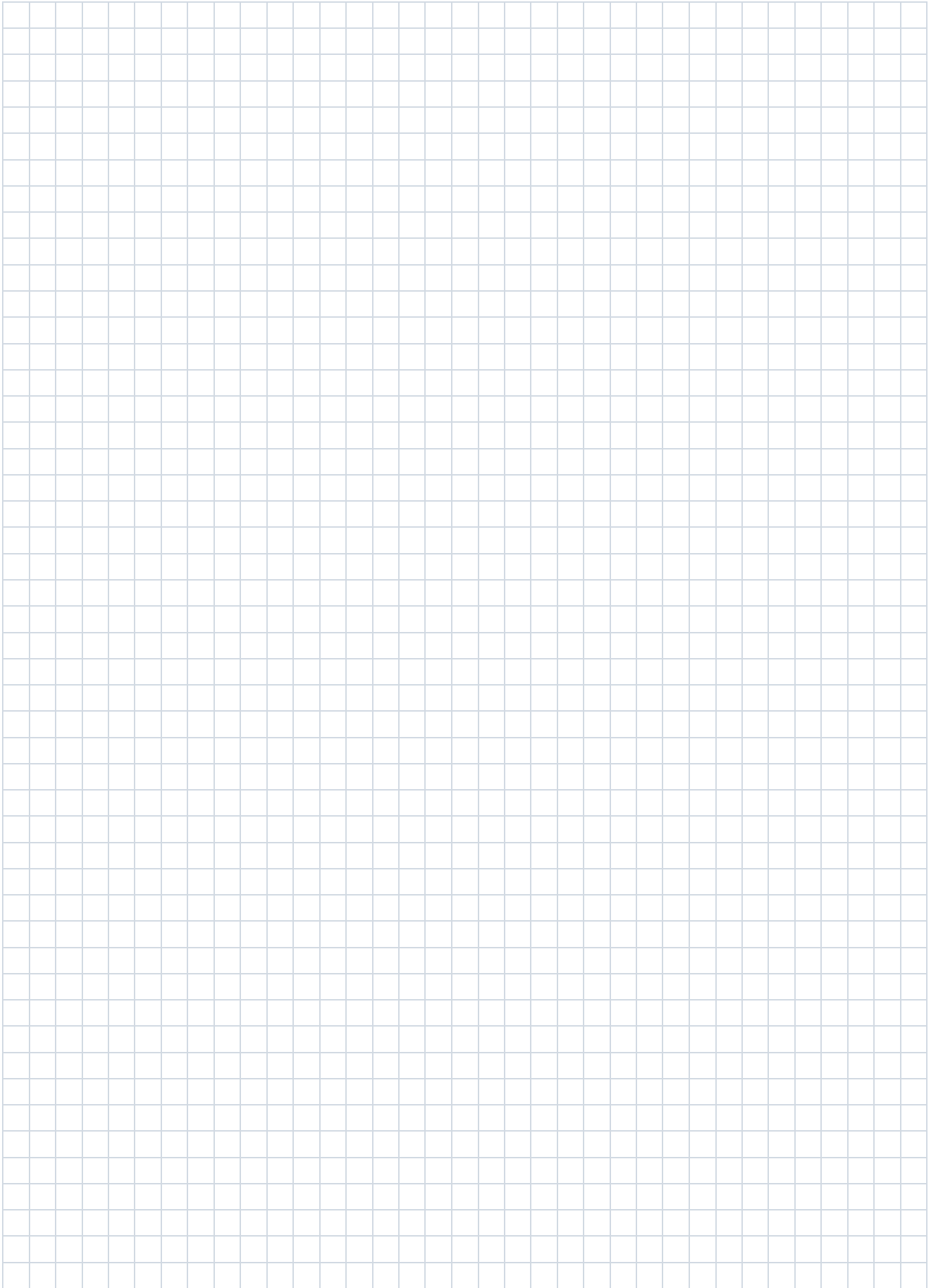

Edition 912907 (US) / 220718 (EU) 06/2011

Subject to modifications without notice

Pepperl+Fuchs Group  
www.pepperl-fuchs.com

USA: +1 330 486 0002  
pa-info@us.pepperl-fuchs.com

Germany: +49 621 776 2222  
pa-info@de.pepperl-fuchs.com

Copyright Pepperl+Fuchs  
Singapore: +65 6779 9091  
pa-info@sg.pepperl-fuchs.com







FB-System



# FB-System

Digital Inputs

Digital Outputs

Analog Inputs

Analog Outputs

Bus Couplers

Power Supplies

Accessories



Edition 912907 (US) / 220178 (EU) 05/2011

|                                  |            |   |
|----------------------------------|------------|---|
| <b>System Description</b> .....  | <b>194</b> |  |
| <b>Digital Inputs</b>            |            |   |
| <b>Selection Tables</b> .....    | <b>201</b> |   |
| <b>Product Data Sheets</b> ..... | <b>202</b> | <b>FB-System</b>  |
| <b>Entity Parameters</b> .....   | <b>210</b> |   |
| <b>Digital Outputs</b>           |            |   |
| <b>Selection Tables</b> .....    | <b>211</b> | <b>Digital Inputs</b>   |
| <b>Product Data Sheets</b> ..... | <b>212</b> |   |
| <b>Entity Parameters</b> .....   | <b>220</b> |   |
| <b>Analog Inputs</b>             |            | <b>Digital Outputs</b>  |
| <b>Selection Tables</b> .....    | <b>221</b> |   |
| <b>Product Data Sheets</b> ..... | <b>222</b> |   |
| <b>Entity Parameters</b> .....   | <b>231</b> | <b>Analog Inputs</b>  |
| <b>Analog Outputs</b>            |            |   |
| <b>Selection Tables</b> .....    | <b>233</b> |   |
| <b>Product Data Sheets</b> ..... | <b>234</b> | <b>Analog Outputs</b>   |
| <b>Entity Parameters</b> .....   | <b>242</b> |   |
| <b>Bus Couplers</b>              |            |   |
| <b>Selection Tables</b> .....    | <b>243</b> |   |
| <b>Product Data Sheets</b> ..... | <b>244</b> |   |
| <b>Power Supplies</b>            |            | <b>Power Supplies</b>   |
| <b>Selection Tables</b> .....    | <b>249</b> |   |
| <b>Product Data Sheets</b> ..... | <b>250</b> |   |
| <b>Accessories</b>               |            | <b>Accessories</b>  |
| <b>Selection Tables</b> .....    | <b>253</b> |   |
| <b>Product Data Sheets</b> ..... | <b>255</b> |   |

## Introduction

FB Remote I/O stations are used as signal conditioning units between field devices and control systems. The devices are mounted in well designed IP66 field enclosures in Zone 1. The various I/O modules may be plugged in or removed from a live circuit. The modules are encapsulated for rough environmental conditions. The flame proof housings allow them to be hot swapped in Zone 1.

FB Remote I/O modules offer advantages in that they are galvanically isolated, they can boost and amplify signals, and are easily mounted as plug-in units. Since they are galvanically isolated they do not require equipotential earth connections normally encountered with safety barriers. Changes in the power supply voltage do not affect the excellent device performance due to the properties of the built-in amplifier circuits. Furthermore they render system I/O cards superfluous. Wiring between them and the system is reduced to a single bus.

LEDs indicate the status of the respective device. A green LED indicates the operating status, while a red LED indicates a fault, e. g. an open line or short circuit. This information can be accessed from the DCS and PLC via a standard bus.

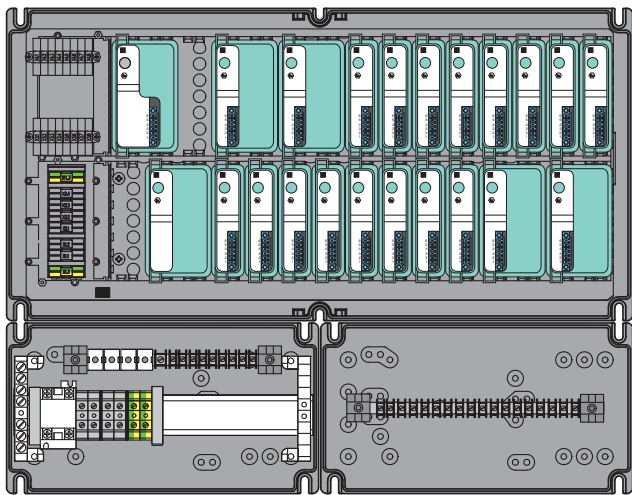

Figure 1 FB Remote I/O station

## Components

### Modules

The compact size of the modules using the proven LB Remote I/O electronics lead to a high packing density. The snap-on fixing method utilizes the very latest moulded plastic technologies, thus allowing the FB Remote I/O modules to be fixed firmly in position without screws. The field connection is made by a coded Phoenix Mini-Combicon connector on the front of the module.

The system is designed in such a way that each module can be plugged into any desired slot on the backplane, whereby the IS connections are adapted to the wiring and not vice-versa. Ex-e connections must be kept separate.

Depending on the size 24, 48 or more I/O modules plus a power supply can be fitted in an enclosure. Depending upon the module type, either 1, 2, 3, 4, or 8 channels can be used.

A wide range of interface modules are available for all kinds of applications, including HART compatible devices.

### Single Width Modules

- 28 mm housing
- Mostly 1-channel devices

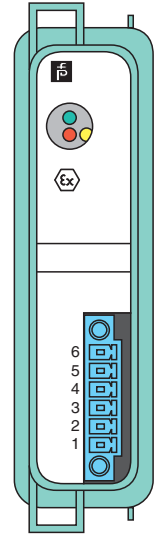

Figure 2 Single width modules

### Dual Width Modules

- 57 mm housing
- Multi channel devices

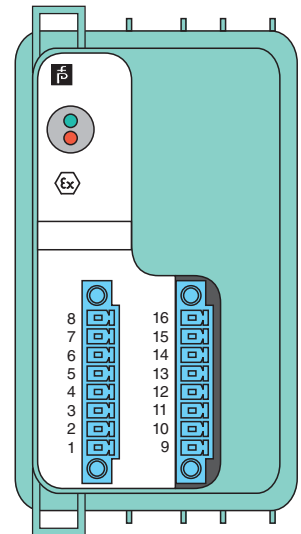

Figure 3 Dual width modules

### Power Supplies

A separate power supply unit supplies up to 24 interface modules. It ensures adherence to the EMC requirements for the overall system according to NAMUR and EMC legislation.

### Communication Units (Com Units)

The Com Unit interfaces the I/O modules with the control system. The unit can serve up to 48 I/O modules and is available for various standard busses. The Com Unit is installed at the left end of the first legacy backplane segment. Ethernet ready backplanes show different gateway positions (see manual).

Com Units are often referred to as gateways or bus couplers all meaning the same function.



FB-System

Digital Inputs

Digital Outputs

Analog Inputs

Analog Outputs

Bus Couplers

Power Supplies

Accessories

### Bus Stations (Backplanes)

Bus stations can be connected to process control systems (DCS) and programmable logic controllers (PLC) of all renowned manufacturers via the available standard busses.

The modular concept allows you to flange enclosures together to arrive at the desired size. Each housing contains Ex-e terminals for power and communication. These are safely covered separately and touch protected.

Backplanes are used to hold I/O modules, Com Units, power supplies and bus termination. The I/O modules act as an interface between signals from the hazardous area (Ex area) and the safe area (non-Ex area). The slots on the backplane have equal status, so that different functions can be installed side-by-side. The configuration is performed via software. Fixed slots are reserved on the backplane for the Com Unit, power supply and bus termination.

The backplanes are fitted inside the enclosure to form an unit. Modular plastic enclosures and stainless steel cabinets are available in different sizes and versions as well as customized solutions. Depending on the version, the units consist of base, redundancy and extension backplanes mounted in the relevant enclosures.

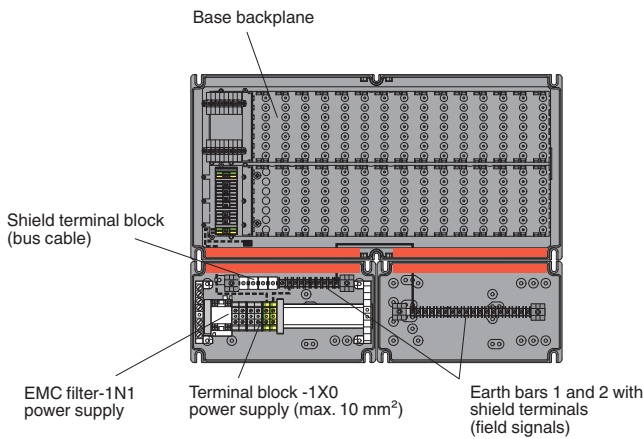

Figure 4 Example backplane

### Field Units (Enclosures)

Field units or enclosures are designed to meet the requirements of the most demanding hazardous area and industrial environmental applications.

The enclosure is fitted with backplanes to accept dual width or single width I/O modules.

Any I/O module can be inserted into any slot, enabling a mixture of I/O types in one field unit.

Power supplies, gateways or Com Units, as well as bus termination modules fit into reserved slots. These are mechanically coded to avoid mix-ups.

The permissible power given in the data sheet concerns the total power consumption determined by the I/O modules. It already includes the power dissipation of the power supply and gateway.

If other consumers featuring a power supply of their own are installed, their power consumption reduces the available power for I/O modules.

Enclosures supplied by Pepperl+Fuchs are built in accordance with the ATEX directive. They will carry a type tag to indicate the temperature class and permissible ambient temperature as well as the permissible installed power.

#### GRP Enclosures

Glass fiber reinforced polyester provides high corrosion resistance for both onshore and offshore installations. Electrostatic charge is avoided by a suitable surface resistance.

#### Stainless Steel Enclosures

The electropolished stainless steel 316L provides high corrosion resistance for both onshore and offshore installations. The one piece seal is protected from standing water damage by the box's integral rain channel.



FB-System

Digital Inputs

Digital Outputs

Analog Inputs

Analog Outputs

Bus Couplers

Power Supplies

Accessories



## Mounting

### Modules

The various I/O modules are slotted into the backplane.

#### Plug & Play

The configuration data of each I/O module is stored in non-volatile memory. Should a fault develop within a module, it can easily be removed and replaced by a standard unprogrammed I/O module.

As soon as a new module has been plugged in the Com Unit renews the setting of the new I/O module, within a fraction of a second, and the device starts to function immediately. There are no potentiometer settings or software actions required at all.

If the wrong type of module is fitted, this is recognized and does not influence the running operation. This also applies for the Com Unit. However, the configuration of the Com Unit must either be loaded from the control system or via the RS 485 service connection. In a redundant system this is carried out automatically.

### Backplanes

The prewired Ex-e IP66 enclosure contains a mechanically compact and robust backplane system. The various Ex-e and IS input/output modules plug into the frame. Proven Ex-d connectors with self cleaning contacts allow modules to be removed in the hazardous area during operation (hot swap).

## Configuration

FB Remote I/O interface modules do not feature internal switches or potentiometers.

They are either configured via the control system or via an easy-to-use Windows™ program and the RS 485 interface in the Com Unit. These can also be configured in the control room and transported to be plugged in in the field. The setting of each and every module is stored in a non-volatile memory in the Com Unit.

Remote I/O slaves can be configured:

- via PROFIBUS using GSE files
- via bus using FDT/DTM or PDM
- via service bus using a software tool

Depending on the Com Unit there are a wide variety of parameters for each module to choose from.

#### Self Generating Documentation

The FB Remote I/O software uses the configuration data to compile a full documentation package. Considerable time and cost savings can be realized by utilizing this feature.

## Communication

### HART Communication

The FB Remote I/O range of products supports HART communication. Provided that the control system can also process the HART protocol, direct communication with the field devices via the PROFIBUS is possible. Alternatively a secondary master can be used on the PROFIBUS line.

Depending upon the type of Com Unit, HART communication is also possible via the service bus.

HART communication with any compatible field device is possible from the control room. For this you have to use the software provided by the manufacturer of the field device or any off-the-shelf software, e. g. Emerson AMS, ABB SMARTVISION, Siemens PDM, E+H Fieldcare, and **PACT<sup>ware</sup>™** etc. HART secondary variables can be mapped into the data exchange.

### PROFIBUS DP V1

PROFIBUS DP V1 allows configuration and parameter settings to be conducted using the control system's engineering tool. You can either use the Pepperl+Fuchs DTM for FDT based systems or EDD for Siemens PDM.

### MODBUS via RS 485 or Ethernet

Suitable Com Units are available for control systems that prefer MODBUS RTU or Ethernet with MODBUS TCP.

## Signal Processing

Independent of the data traffic on the system bus, the I/O modules constantly transmit the incoming signals into an internal bus format using the high integrity Manchester code. The reverse is the case for outgoing signals. One task of the Com Unit is to ensure the quick transfer of data to the I/O modules. The internal memory of the Com Unit contains a complete image of the field signals at all times.

As the Com Unit is the only interface between the FB Remote I/O and the standard bus of the main control system, future bus developments in this field can also be taken care of.

## Functionality

### Redundancy

Com Units are fitted with two galvanically isolated bus connections. The system bus interfaces with the DCS or PLC. The service bus is available for commissioning, maintenance and HART communications (version dependant). In a redundant system a second system bus is added. Pepperl+Fuchs supplies proven redundant systems well established with renowned DCS manufacturers. In most cases a service bus is not required as communication and parameterization can be accomplished via the main bus.

See the "Redundancy" section on page 14 for details.

FB-System

Digital  
InputsDigital  
OutputsAnalog  
InputsAnalog  
OutputsBus  
CouplersPower  
Supplies

Accessories



## Graded Redundancy

As each control system has its own individual requirements, the FB Remote I/O series was provided with a graded redundancy concept.

## Redundant Com Units

Two Com Units can operate in parallel so that a bumpless transition can take place in case of a fault in one of them.

## Redundant Selectors

Both Com Units can access the internal bus via redundant selectors.

## Line Redundancy

A field station features two redundant Com Units. The field bus is also redundant. The transmission lines of the master are connected to the active and passive Com Units via both bus lines. In order to be able to access both bus lines, the master features a voter or two repeaters for the receiving lines.

## Application Redundancy

A field station features two redundant Com Units. To be able to access both bus lines, the master features two redundant interfaces. Both Com Units are active on both external busses. Only one Com Unit is active on the internal bus and can define outputs.

## Power Supply Redundancy

Redundant Com Units are powered via power supplies positioned in the base unit and the redundancy units. The extension unit features two power supplies. In case of a failure the second power supply ensures continued operation. A diagnostic flag is sent to the DCS system.

## Line Fault Detection (LFD)

Almost all FB Remote I/O series I/O modules have a sophisticated line fault detection system. This feature can be enabled or disabled for each channel individually.

## Safety Information

The corresponding data sheets, the Declaration of Conformity, the EC-Type Examination Certificate and applicable certificates (see data sheet) are an integral part of this document.

For information see manuals, operating instructions and [www.pepperl-fuchs.com](http://www.pepperl-fuchs.com).

## Common Technical Data

### Modules

#### Electrical Data

##### Rated Voltage

see individual data sheet

##### Power Consumption

see individual data sheet

#### Mechanical Data

##### Mounting

- Plug-in mounting on backplane
- The modules have to be mounted in appropriate backplanes and housings (FB 92\*\* or FB 93\*\*) in Zone 1, 2, 21, 22 or outside hazardous areas (gas or dust). Here EC-Type Examination Certificate PTB 97 ATEX 1075 has to be observed.

##### Material

Plastic

##### Dimensions

- Single width modules: 28 mm x 107 mm x 132 mm (1.1 in x 4.2 in x 5.2 in)
- Dual width modules: 57 mm x 107 mm x 132 mm (2.2 in x 4.2 in x 5.2 in)

##### Protection Degree

IP20 acc. to EN 60529, mounted on backplane

##### Connection

Device plug (accessories)

- removable terminals
- plug with screw flange
- wiring connection:
  - spring terminals: (0.14 mm<sup>2</sup> ... 1.5 mm<sup>2</sup>)
  - screw terminals: (0.08 mm<sup>2</sup> ... 1.5 mm<sup>2</sup>)

##### Labeling

Space for labeling on the front

##### Ambient Conditions

##### Ambient Temperature

-20 °C ... 60 °C (-4 °F ... 140 °F)

##### Storage Temperature

-25 °C ... 85 °C (-13 °F ... 185 °F)

##### Reference Conditions for Device Calibration

20 °C (68 °F)

##### Relative Humidity

acc. to EN 60068-2-56, 95 %, non-condensing

##### Vibration Resistance

acc. to EN 60068-2-6, frequency range 5 Hz ... 500 Hz, amplitude 5 Hz ... 13.2 Hz ± 1.5 mm, 13.2 Hz ... 100 Hz 1 g, sweep rate 1 octave/min, duration 10 sweeps  
5 Hz - 100 Hz - 5 Hz



FB-System

Digital Inputs

Digital Outputs

Analog Inputs

Analog Outputs

Bus Couplers

Power Supplies

Accessories

## Shock Resistance

acc. to EN 60068-2-27, shock type I, shock duration 11 ms, shock amplitude 50 m/s<sup>2</sup>, number of shock directions 6, number of shocks per direction 100

## Damaging Gas

acc. to EN 60068-2-42, for plugs: 21 days in 25 ppm SO<sub>2</sub>, at 25 °C and 75 % rel. humidity, device G3

## Conformity with Standards and Directives

### General

- Isolator modules with explosion protection, mostly with Ex ia IIC, international approvals
- EMC acc. to NAMUR NE21 and EN 61326
- LEDs acc. to NAMUR NE44
- Software acc. to NAMUR NE53
- Switch-on pulse suppression
- Supply voltage 20 V DC to 30 V DC or 115/230 V AC ±10 %
- Functional safety devices acc. to IEC 61508 (SIL)

## Backplanes

### Electrical Data

#### Rated Voltage

24 V DC, 115 V AC, 230 V AC, depends on power supply

#### Power Consumption

see individual data sheet

### Mechanical Data

#### Mounting

- Installation in Zone 1, 2, 21, 22, or safe area, see individual data sheet
- Mounted on an earthed metal surface by means of 12 screws.

#### Material

Plastic

#### Dimensions

see individual data sheet

#### Labeling

Labeled ex-works

## Field Units (Enclosures)

### Electrical Data

#### Rated Voltage

24 V DC, 115 V AC, 230 V AC, depends on power supply

#### Power Consumption/Power Dissipation

see individual data sheet

#### Permissible Power for Enclosures

The permissible power per enclosure determines the number of I/O modules that may be fitted to stay within the limits for the maximum temperature inside the enclosure.

## Stainless Steel Enclosures

| Enclosure dimensions (mm)<br>(W x H x D) | Permissible power P <sub>max</sub> (W)* |               |
|--|---|---------------|
|  | wall mounted                            | free standing |
| 350 x 306 x 215                          | 43                                      | 54            |
| 600 x 400 x 220                          | 75                                      | 101           |
| 600 x 600 x 220                          | 97                                      | 137           |
| 700 x 350 x 220                          | 78                                      | 105           |
| 800 x 800 x 300                          | 176                                     | 246           |
| 800 x 1000 x 300                         | 206                                     | 295           |

\* P<sub>max</sub> at 40 °C (104 °F) ambient temperature and 60 °C inside temperature  
 P<sub>max</sub> at 50 °C (122 °F) ambient temperature and 60 °C (140 °F) inside the permissible power is halved

Table 1

The following calculation examples are based on the module power consumption. More recently data sheets distinguish between power consumption and power dissipation. The power consumption is used to calculate the permissible load of the power supply. The power dissipation is used to calculate the permissible power inside an enclosure. When the data sheet does not specify any power dissipation use the power consumption to calculate the maximum power inside an enclosure.

### Calculation Example for Enclosure Type FB 9248-S70-0-0-0-0-0 (800 x 800 x 300 mm)

#### Assumptions

- Permissible power: 176 W (wall mounted)
- Ambient temperature: 40 °C (104 °F)
- Max. temperature inside: 60 °C (140 °F)
- Temperature class: T6

#### Permissible number of I/O modules

- 20 x FB 4205 (analog output): 60 W or
- 20 x FB 6214 (digital output) and 4 x FB 9205 C (power supply): 12 W + 120 W or
- 48 x FB 1201 (digital input): 24 W

## GRP Enclosures

| Enclosure dimensions (mm)<br>(W x H x D) | Permissible power P <sub>max</sub> (W)* |
|--|---|
| 544 x 271 x 210                          | 34                                      |
| 544 x 407 x 210                          | 43                                      |
| 544 x 544 x 210                          | 53                                      |

\* P<sub>max</sub> at 40 °C (104 °F) ambient temperature and 60 °C inside temperature  
 P<sub>max</sub> at 50 °C (122 °F) ambient temperature and 60 °C (140 °F) inside the permissible power is halved

Table 2

### Calculation Example for Enclosure Type FB 9224-PG0-0-0-0-0-0 (544 x 407 x 210 mm)

#### Assumptions

- Permissible power: 21.5 W
- Ambient temperature: 50 °C (122 °F)
- Max. temperature inside: 60 °C (140 °F)
- Temperature class: T4

Edition 912907 (US) / 220718 (EU) 06/2011

Permissible number of I/O modules

- 10 x FB 4205 (analog output): 30 W x 0.7 or
- 7 x FB 6214 (digital output) and 2 x FB 1201 (digital input): (4.2 W + 24.7 W + 1 W) x 0.7 or
- 16 x FB 1201 (digital input): 8 W

When the permissible power is much larger than the power consumption use the values from the data sheet.

When the permissible power and the power consumption are much closer as in the second example, the calculation can use a factor of 0.7. The factor of 0.7 is based on DIN IEC 60364-7-718; VDE 0100-718:2008-05.

## Mechanical Data

### Mounting

Installation in Zone 1, 2, 21, 22, or safe area, see individual data sheet

### Material

#### GRP Enclosure

- Housing: polyester, impact resistant, glass fiber reinforced
- Surface: black molded finish (RAL 9005)
- Cable glands: polyamide (PA)
- Seal: silicon, one piece

#### Stainless Steel Enclosure

- Housing: stainless steel 1.4404/316L
- Surface: electropolished
- Cable glands: polyamide (PA)
- Seal: neoprene, fire resistant, one piece

### Dimensions

see individual data sheet

### Protection Degree

IP54 (Zone 2 or 22), IP6X (flammable dust)

Our own IP66 enclosures exceed these minimum requirements.

### Connection

- Supply: screw terminals, max. 2.5 mm<sup>2</sup>
- Fieldbus interface: depends on the backplane
  - PROFIBUS DP V1 and MODBUS RTU: 9-pin Sub-D connector
  - MODBUS TCP/IP: RJ45 connector
  - FOUNDATION fieldbus: wire clamp terminals, max. 2.5 mm<sup>2</sup>

## Ambient Conditions

### Ambient Temperature

- -20 °C ... 55 °C (-4 °F ... 131 °F) at T4
- -20 °C ... 40 °C (-4 °F ... 104 °F) at T6

### Storage Temperature

-40 °C ... 70 °C (-40 °F ... 158 °F)

## Accessories

### Mounting Accessories

An extension cable is used to make up a substation of two backplanes mounted side by side or below one another in an enclosure. That way you can build the following maximum slave combinations:

Base backplane and extension backplane each with

- 24 slots for 1-channel modules or
  - 12 slots for multi-channel modules
- or a combination thereof to arrive at
- 192/160 digital I/O max. (legacy or Ethernet)
  - 80 analog I/O max.

### Plugs

Sensors and actuators are adapted via front end screw plug-in connectors. Wire clamp connections on request. Intrinsically safe and non-intrinsically safe modules can be mounted next to each other. The latter are fitted with covered increased safety connections.

### Bus Connection/Power Supply

Bus and power are wired to the terminal block on the left of the backplane.

Redundant gateways and power supplies ensure continued operation should one of them fail.

### Cold Junction Compensation (CJC)/Coding

A connector with built-in CJC is available for thermocouple measurements. Connectors can be coded mechanically to avoid mix-ups.

### Software

The following software is available:

- GSE files
- DD files for Siemens PDM
- Fhx files for Emerson DeltaV
- **PACT<sup>ware</sup>**™ configuration tool
- DTM via internet download
- System drivers at request

For additional details, see accessory section and data sheets. Other accessories at request.



FB-System

Digital Inputs

Digital Outputs

Analog Inputs

Analog Outputs

Bus Couplers

Power Supplies

Accessories





Digital Inputs

| Model Number | Channels | Occupied Slots | Input (Field)      |                                     |                 |                            | Input Ex ia | Input Ex e | Mounting in Suitable Enclosures in Zone 1 and Zone 21 | Page |
|--------------|----------|----------------|--------------------|-------------------------------------|-----------------|----------------------------|-------------|------------|---|------|
|              |          |                | NAMUR/Dry Contacts | Frequency and Direction of Rotation | Up/Down Counter | Line Fault Detection (LFD) |             |            |   |      |
| FB 1201 B    | 2        | 1              | ■                  |                                     |                 | ■                          | ■           | ■          | 202   |      |
| FB 1202 B    | 3        | 1              | ■                  |                                     |                 | ■                          | ■           | ■          | 203   |      |
| FB 1203 *    | 1        | 1              | ■                  | ■                                   | ■               | ■                          | ■           | ■          | 204   |      |
| FB 1208 B    | 8        | 2              | ■                  |                                     |                 | ■                          | ■           | ■          | 205   |      |
| FB 1301 **   | 2        | 1              | ■                  |                                     |                 | ■                          | ■           | ■          | 206   |      |
| FB 1302 **   | 3        | 1              | ■                  |                                     |                 | ■                          | ■           | ■          | 207   |      |
| FB 1303 **   | 1        | 1              | ■                  | ■                                   | ■               | ■                          | ■           | ■          | 208   |      |
| FB 1308 **   | 8        | 2              | ■                  |                                     |                 | ■                          | ■           | ■          | 209   |      |

  
**FB-System**
  
**Digital Inputs**
  
**Digital Outputs**
  
**Analog Inputs**
  
**Analog Outputs**
  
**Bus Couplers**
  
**Power Supplies**
  
**Accessories**

Edition 912907 (US) / 220718 (EU) 06/2011

Subject to modifications without notice

Pepperl+Fuchs Group  
www.pepperl-fuchs.com

USA: +1 330 486 0002  
pa-info@us.pepperl-fuchs.com

Germany: +49 621 776 2222  
pa-info@de.pepperl-fuchs.com

Copyright Pepperl+Fuchs

Singapore: +65 6779 9091  
pa-info@sg.pepperl-fuchs.com



FB-System

Digital Inputs

Digital Outputs

Analog Inputs

Analog Outputs

Bus Couplers

Power Supplies

Accessories

**Features**

- 2-channel
- Inputs Ex ia
- Dry contact or NAMUR inputs
- Galvanic isolation between channels and the bus
- Installation in suitable enclosures in Zone 1 and Zone 21
- Module can be exchanged under voltage in Zone 1 (hot swap)
- Positive or negative logic selectable
- Simulation mode for service operations (forcing)
- Line fault detection (LFD)
- Permanently self-monitoring
- EMC acc. to NAMUR NE 21

**Function**

The device accepts digital input signals of NAMUR sensors or mechanical contacts from the hazardous area.

Open or short circuit line fault alarms are detected.

The intrinsically safe inputs are galvanically isolated from the bus and the power supply (EN 60079-11).

**Technical data**

**Supply**

|               |   |
|---------------|---|
| Connection    | backplane bus   |
| Rated voltage | 12 V DC, only in connection with the power supplies FB 92** |

|                   |       |
|-------------------|-------|
| Power consumption | 0.5 W |
|-------------------|-------|

**Internal bus**

|            |  |
|------------|--|
| Connection | backplane bus  |
| Interface  | manufacturer specific bus to standard Com Unit/gateway |

**Input**

|                                      |  |
|--------------------------------------|--|
| Suitable sensors                     | mechanical contacts, NAMUR proximity switches, 2-wire initiators   |
| Connection                           | terminals 1+, 2-; 4+, 5-   |
| Rated values                         | acc. to EN 60947-5-6 (NAMUR)   |
| Switching point/switching hysteresis | 1.2 ... 2.1 mA/± 0.2 mA  |
| Line fault detection                 | option: On/Off, for each channel<br>mechanical switches: see connection diagram<br>NAMUR proximity switches: no replacement network required<br>switching points:<br>- short circuit: typical < 360 Ω, certain < 100 Ω<br>- open circuit: typical < 0.35 mA, certain < 0.05 mA |

|                   |                |
|-------------------|----------------|
| Voltage           | 8.2 V, typical |
| Internal resistor | approx. 1 kΩ   |

**Ambient conditions**

|                     |                                |
|---------------------|--------------------------------|
| Ambient temperature | -20 ... 60 °C (-4 ... 140 °F)  |
| Storage temperature | -25 ... 85 °C (-13 ... 185 °F) |

**Mechanical specifications**

|  |  |
|--|--|
| Protection degree                                | IP20 (module), a separate housing is required acc. to the system description |
| Mass   | approx. 350 g  |
| Dimensions                                       | 28 x 107 x 132 mm (1.1 x 4.2 x 5.2 in)                                       |
| Data for application in connection with Ex-areas | see page 210 for entity parameters   |

|                                     |   |
|-------------------------------------|---|
| EC-Type Examination Certificate     | PTB 97 ATEX 1074 U, PTB 97 ATEX 1075 (system) |
| Group, category, type of protection | ⊕ II 2 (1) G Ex d [ia] IIC, [Ex iaD]          |

|        |  |
|--------|--|
| Supply | only in connection with the power supplies FB 92** |
|--------|--|

|                      |   |
|----------------------|---|
| Directive conformity |   |
| Directive 94/9/EC    | EN 60079-0, EN 60079-1, EN 60079-11, EN 60079-26, EN 61241-0, EN 61241-11 |

**International approvals**

|                |         |
|----------------|---------|
| IECEx approval | pending |
|----------------|---------|

**Diagrams**

Front view

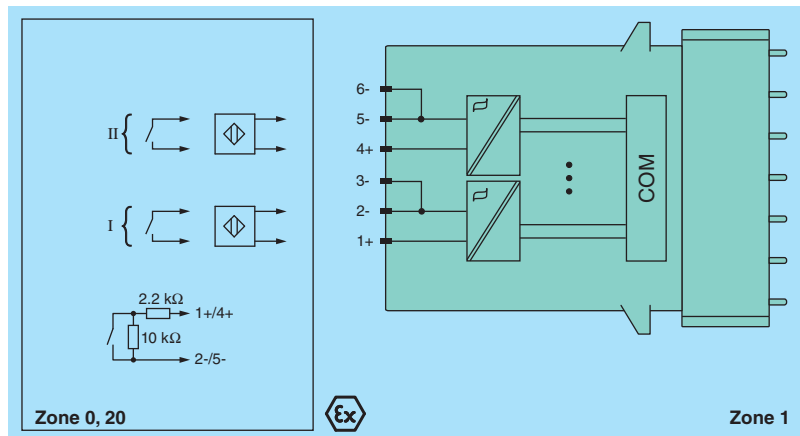
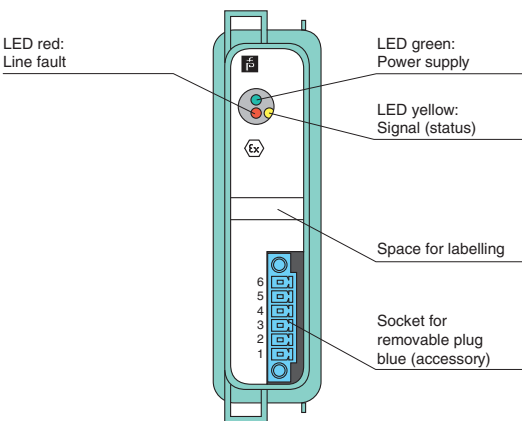

Edition 912907 (US) / 220718 (EU) 06/2011



| Technical data  |  |
|---|--|
| <b>Supply</b>   |  |
| Connection  | backplane bus  |
| Rated voltage   | 12 V DC, only in connection with the power supplies FB 92**  |
| Power consumption                                       | 0.5 W  |
| <b>Internal bus</b>                                     |  |
| Connection  | backplane bus  |
| Interface   | manufacturer specific bus to standard Com Unit/gateway   |
| <b>Input</b>  |  |
| Suitable sensors  | mechanical contacts, NAMUR proximity switches, 2-wire initiators   |
| Connection  | terminals 1+, 4-, 2+, 5-, 3+, 6-   |
| Rated values  | acc. to EN 60947-5-6 (NAMUR)   |
| Switching point/switching hysteresis                    | 1.2 ... 2.1 mA ± 0.2 mA  |
| Line fault detection                                    | option: On/Off, for each channel<br>mechanical switches: see connection diagram<br>NAMUR proximity switches: no replacement network required<br>switching points:<br>- short circuit: typical < 360 Ω, certain < 100 Ω<br>- open circuit: typical < 0.35 mA, certain < 0.05 mA |
| Voltage   | 8.2 V, typical   |
| Internal resistor                                       | approx. 1 kΩ   |
| <b>Ambient conditions</b>                               |  |
| Ambient temperature                                     | -20 ... 60 °C (-4 ... 140 °F)  |
| Storage temperature                                     | -25 ... 85 °C (-13 ... 185 °F)   |
| <b>Mechanical specifications</b>                        |  |
| Protection degree                                       | IP20 (module), a separate housing is required acc. to the system description   |
| Mass  | approx. 330 g  |
| Dimensions  | 28 x 107 x 132 mm (1.1 x 4.2 x 5.2 in)   |
| <b>Data for application in connection with Ex-areas</b> | see page 210 for entity parameters   |
| EC-Type Examination Certificate                         | PTB 97 ATEX 1074 U, PTB 97 ATEX 1075 (system)  |
| Group, category, type of protection                     | ⊕ II 2 (1) G Ex d [ia] IIC, [Ex iaD]   |
| Supply  | only in connection with the power supplies FB 92**   |
| Directive conformity                                    |  |
| Directive 94/9/EC                                       | EN 60079-0, EN 60079-1, EN 60079-11, EN 60079-26, EN 61241-0, EN 61241-11  |
| <b>International approvals</b>                          |  |
| IECEx approval  | pending  |

**Features**

- 3-channel
- Inputs Ex ia
- Dry contact or NAMUR inputs
- Galvanic isolation between inputs and bus (group isolation)
- Installation in suitable enclosures in Zone 1 and Zone 21
- Module can be exchanged under voltage in Zone 1 (hot swap)
- Positive or negative logic selectable
- Simulation mode for service operations (forcing)
- Line fault detection (LFD)
- Permanently self-monitoring
- EMC acc. to NAMUR NE 21

**Function**

The device accepts up to 3 digital input signals of NAMUR sensors or mechanical contacts from the hazardous area.

Open or short circuit line fault alarms are detected.

The inputs are galvanically isolated from the bus and the power supply (EN 60079-11).

**Diagrams**

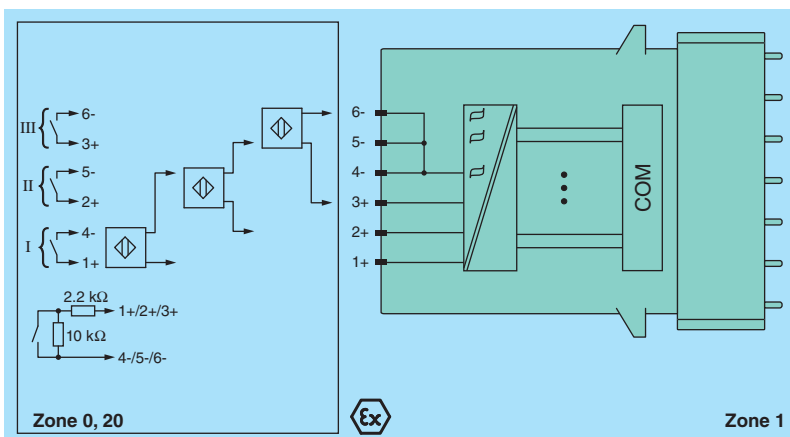

Front view

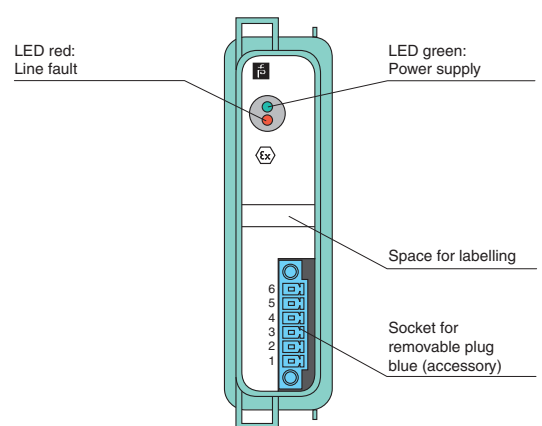

Edition 912907 (US) / 220718 (EU) 06/2011



FB-System

Digital Inputs

Digital Outputs

Analog Inputs

Analog Outputs

Bus Couplers

Power Supplies

Accessories

**Features**

- 1-channel
- Input Ex ia
- Input for frequency, counter, direction of rotation
- Digital input max. 15 kHz for FB 1203 B
- Digital input max. 400 Hz for FB 1203 D
- Installation in suitable enclosures in Zone 1 and Zone 21
- Module can be exchanged under voltage in Zone 1 (hot swap)
- Positive or negative logic selectable
- Simulation mode for service operations (forcing)
- Line fault detection (LFD)
- Permanently self-monitoring
- EMC acc. to NAMUR NE 21

**Function**

The device accepts digital input signals of NAMUR sensors or mechanical contacts from the hazardous area.

Open or short circuit line fault alarms are detected.

The intrinsically safe inputs are galvanically isolated from the bus and the power supply (EN 60079-11).

**Technical data**

**Supply**

|               |   |
|---------------|---|
| Connection    | backplane bus   |
| Rated voltage | 12 V DC, only in connection with the power supplies FB 92** |

|                   |       |
|-------------------|-------|
| Power consumption | 0.6 W |
|-------------------|-------|

**Internal bus**

|            |  |
|------------|--|
| Connection | backplane bus  |
| Interface  | manufacturer specific bus to standard Com Unit/gateway |

**Input**

|                                      |  |
|--------------------------------------|--|
| Suitable sensors                     | Frequency, counter, direction of rotation, NAMUR proximity switches, 2-wire initiators, mech. contacts   |
| Connection                           | terminals 1+, 2-: input; 4+, 5-: direction   |
| Rated values                         | acc. to EN 60947-5-6 (NAMUR)   |
| Switching point/switching hysteresis | 1.2 ... 2.1 mA/± 0.2 mA  |
| Line fault detection                 | option: On/Off, for each channel<br>mechanical switches: see connection diagram<br>NAMUR proximity switches: no replacement network required<br>switching points:<br>- short circuit: typical < 360 Ω, certain < 100 Ω<br>- open circuit: typical < 0.35 mA, certain < 0.05 mA |

|         |                |
|---------|----------------|
| Voltage | 8.2 V, typical |
|---------|----------------|

|                   |              |
|-------------------|--------------|
| Internal resistor | approx. 1 kΩ |
|-------------------|--------------|

|                     |                     |
|---------------------|---------------------|
| Operating frequency | 0 ... 15 kHz/400 Hz |
|---------------------|---------------------|

**Ambient conditions**

|                     |                               |
|---------------------|-------------------------------|
| Ambient temperature | -20 ... 60 °C (-4 ... 140 °F) |
|---------------------|-------------------------------|

|                     |                                |
|---------------------|--------------------------------|
| Storage temperature | -25 ... 85 °C (-13 ... 185 °F) |
|---------------------|--------------------------------|

**Mechanical specifications**

|                   |  |
|-------------------|--|
| Protection degree | IP20 (module), a separate housing is required acc. to the system description |
|-------------------|--|

|      |               |
|------|---------------|
| Mass | approx. 350 g |
|------|---------------|

|            |  |
|------------|--|
| Dimensions | 28 x 107 x 132 mm (1.1 x 4.2 x 5.2 in) |
|------------|--|

|   |                                    |
|---|------------------------------------|
| <b>Data for application in connection with Ex-areas</b> | see page 210 for entity parameters |
|---|------------------------------------|

|                                 |   |
|---------------------------------|---|
| EC-Type Examination Certificate | PTB 97 ATEX 1074 U, PTB 97 ATEX 1075 (system) |
|---------------------------------|---|

|                                     |                                      |
|-------------------------------------|--------------------------------------|
| Group, category, type of protection | ⊕ II 2 (1) G Ex d [ia] IIC, [Ex iaD] |
|-------------------------------------|--------------------------------------|

|        |  |
|--------|--|
| Supply | only in connection with the power supplies FB 92** |
|--------|--|

**Directive conformity**

|                   |   |
|-------------------|---|
| Directive 94/9/EC | EN 60079-0, EN 60079-1, EN 60079-11, EN 60079-26, EN 61241-0, EN 61241-11 |
|-------------------|---|

**International approvals**

|                |         |
|----------------|---------|
| IECEx approval | pending |
|----------------|---------|

**Diagrams**

Front view

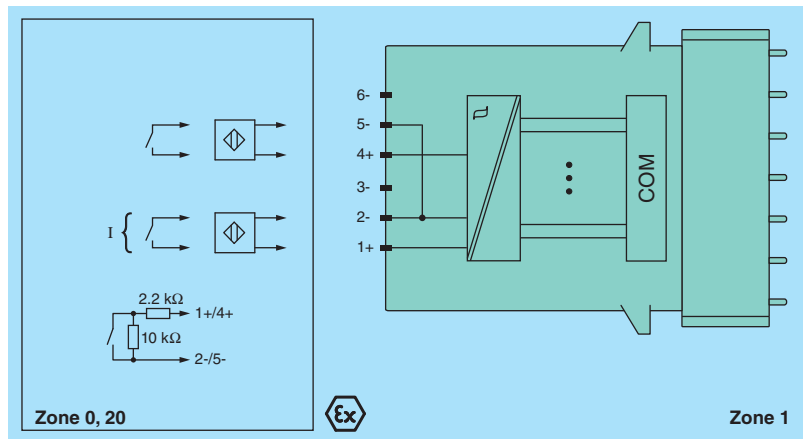
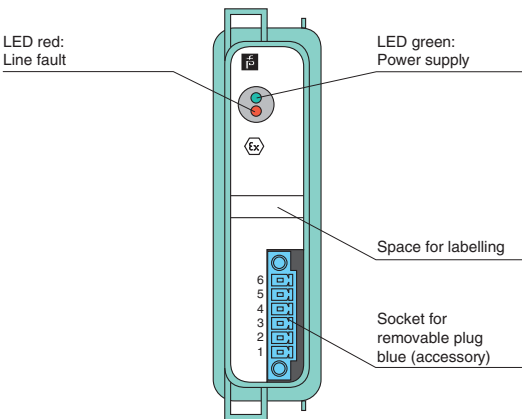

Edition 912907 (US) / 220718 (EU) 06/2011

| Technical data  |  |
|---|--|
| <b>Supply</b>   |  |
| Connection  | backplane bus  |
| Rated voltage   | 12 V DC, only in connection with the power supplies FB 92**  |
| Power consumption                                       | 0.7 W  |
| <b>Internal bus</b>                                     |  |
| Connection  | backplane bus  |
| Interface   | manufacturer specific bus to standard Com Unit/gateway   |
| <b>Input</b>  |  |
| Suitable sensors  | mechanical contacts, NAMUR proximity switches, 2-wire initiators   |
| Connection  | terminals 1+, 2-; 3+, 4-; 5+, 6-; 7+, 8-; 9+, 10-; 11+, 12-; 13+, 14-; 15+, 16-  |
| Rated values  | acc. to EN 60947-5-6 (NAMUR)   |
| Switching point/switching hysteresis                    | 1.2 ... 2.1 mA ± 0.2 mA  |
| Line fault detection                                    | option: On/Off, for each channel<br>mechanical switches: see connection diagram<br>NAMUR proximity switches: no replacement network required<br>switching points:<br>- short circuit: typical < 360 Ω, certain < 100 Ω<br>- open circuit: typical < 0.35 mA, certain < 0.05 mA |
| Voltage   | 8.2 V, typical   |
| Internal resistor                                       | approx. 1 kΩ   |
| <b>Ambient conditions</b>                               |  |
| Ambient temperature                                     | -20 ... 60 °C (-4 ... 140 °F)  |
| Storage temperature                                     | -25 ... 85 °C (-13 ... 185 °F)   |
| <b>Mechanical specifications</b>                        |  |
| Protection degree                                       | IP20 (module), a separate housing is required acc. to the system description   |
| Mass  | approx. 750 g  |
| Dimensions  | 57 x 107 x 132 mm (2.2 x 4.2 x 5.2 in)   |
| <b>Data for application in connection with Ex-areas</b> | see page 210 for entity parameters   |
| EC-Type Examination Certificate                         | PTB 97 ATEX 1074 U, PTB 97 ATEX 1075 (system)  |
| Group, category, type of protection                     | ⊕ II 2 (1) G Ex d [ia] IIC, [Ex iaD]   |
| Supply  | only in connection with the power supplies FB 92**   |
| Directive conformity                                    |  |
| Directive 94/9/EC                                       | EN 60079-0, EN 60079-1, EN 60079-11, EN 60079-26, EN 61241-0, EN 61241-11  |
| <b>International approvals</b>                          |  |
| IECEx approval  | pending  |

**Features**

- 8-channel
- Inputs Ex ia
- Dry contact or NAMUR inputs
- Galvanic isolation between inputs and bus (group isolation)
- Installation in suitable enclosures in Zone 1 and Zone 21
- Module can be exchanged under voltage in Zone 1 (hot swap)
- Positive or negative logic selectable
- Simulation mode for service operations (forcing)
- Line fault detection (LFD)
- Permanently self-monitoring
- On/Off delay
- EMC acc. to NAMUR NE 21

**Function**

The device accepts digital input signals of NAMUR sensors or mechanical contacts from the hazardous area.

Open or short circuit line fault alarms are detected.

The inputs are galvanically isolated from the bus and the power supply (EN 60079-11).

**Diagrams**

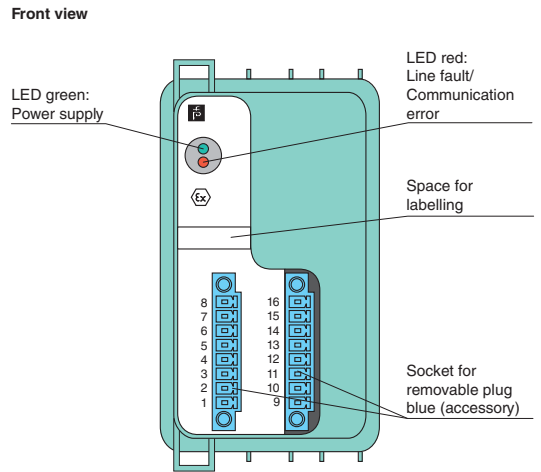
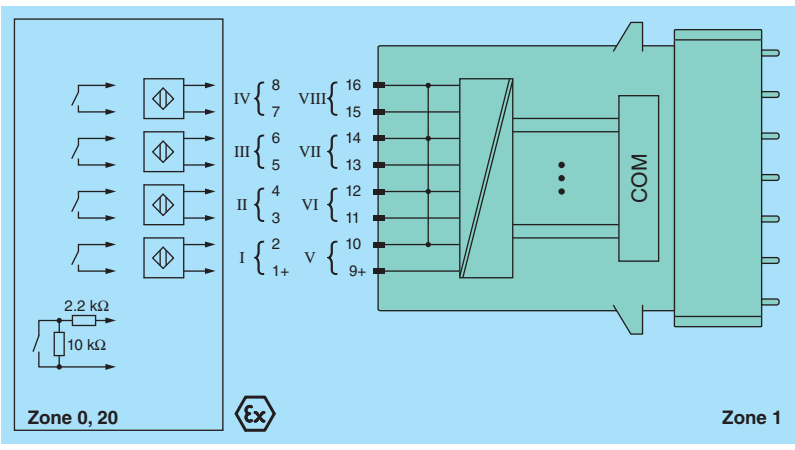

Edition 912907 (US) / 220718 (EU) 06/2011



FB-System

Digital Inputs

Digital Outputs

Analog Inputs

Analog Outputs

Bus Couplers

Power Supplies

Accessories

**Features**

- 2-channel
- Inputs wired to Ex e terminals
- Dry contact or NAMUR inputs
- Galvanic isolation between channels and the bus
- Installation in suitable enclosures in Zone 1 and Zone 21
- Module can be exchanged under voltage in Zone 1 (hot swap)
- Positive or negative logic selectable
- Simulation mode for service operations (forcing)
- Line fault detection (LFD)
- Permanently self-monitoring
- EMC acc. to NAMUR NE 21

**Function**

The device accepts digital input signals of NAMUR sensors or mechanical contacts from the hazardous area.

Open or short circuit line fault alarms are detected.

The intrinsically safe inputs are galvanically isolated from the bus and the power supply (EN 60079-11).

**Technical data**

**Supply**

|               |   |
|---------------|---|
| Connection    | backplane bus   |
| Rated voltage | 12 V DC, only in connection with the power supplies FB 92** |

|                   |       |
|-------------------|-------|
| Power consumption | 0.5 W |
|-------------------|-------|

**Internal bus**

|            |  |
|------------|--|
| Connection | backplane bus  |
| Interface  | manufacturer specific bus to standard Com Unit/gateway |

**Input**

|                                      |  |
|--------------------------------------|--|
| Suitable sensors                     | mechanical contacts, NAMUR proximity switches, 2-wire initiators   |
| Connection                           | wire ends 1+ (white), 2- (brown); 4+ (yellow), 5- (grey)   |
| Rated values                         | acc. to EN 60947-5-6 (NAMUR)   |
| Switching point/switching hysteresis | 1.2 ... 2.1 mA/± 0.2 mA  |
| Line fault detection                 | option: On/Off, for each channel<br>mechanical switches: see connection diagram<br>NAMUR proximity switches: no replacement network required<br>switching points:<br>- short circuit: typical < 360 Ω, certain < 100 Ω<br>- open circuit: typical < 0.35 mA, certain < 0.05 mA |

|                   |                |
|-------------------|----------------|
| Voltage           | 8.2 V, typical |
| Internal resistor | approx. 1 kΩ   |

**Ambient conditions**

|                     |                                |
|---------------------|--------------------------------|
| Ambient temperature | -20 ... 60 °C (-4 ... 140 °F)  |
| Storage temperature | -25 ... 85 °C (-13 ... 185 °F) |

**Mechanical specifications**

|                   |  |
|-------------------|--|
| Protection degree | IP20 (module), a separate housing is required acc. to the system description |
| Mass              | approx. 350 g  |
| Dimensions        | 28 x 107 x 132 mm (1.1 x 4.2 x 5.2 in)                                       |

**Data for application in connection with Ex-areas**

|                                     |  |
|-------------------------------------|--|
| EC-Type Examination Certificate     | PTB 97 ATEX 1074 U, PTB 97 ATEX 1075 (system)      |
| Group, category, type of protection | ⊕ II 2 G Ex d II C                                 |
| Supply                              | only in connection with the power supplies FB 92** |
| Directive conformity                |  |
| Directive 94/9/EC                   | EN 60079-0, EN 60079-1                             |

**International approvals**

|                |         |
|----------------|---------|
| IECEX approval | pending |
|----------------|---------|

**Diagrams**

Front view

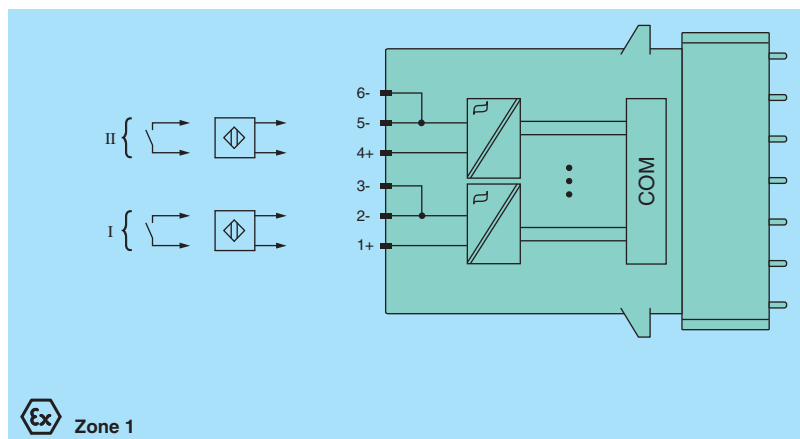
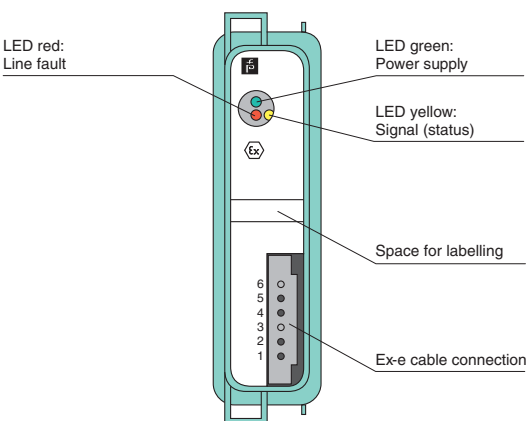

Edition 912907 (US) / 220718 (EU) 06/2011

| Technical data  |  |
|---|--|
| <b>Supply</b>   |  |
| Connection  | backplane bus  |
| Rated voltage   | 12 V DC, only in connection with the power supplies FB 92**  |
| Power consumption                                       | 0.5 W  |
| <b>Internal bus</b>                                     |  |
| Connection  | backplane bus  |
| Interface   | manufacturer specific bus to standard Com Unit/gateway   |
| <b>Input</b>  |  |
| Suitable sensors  | mechanical contacts, NAMUR proximity switches, 2-wire initiators   |
| Connection  | wire ends 1+ (white), 2+ (brown), 3+ (green), 4- (yellow), 5- (grey), 6- (pink)  |
| Rated values  | acc. to EN 60947-5-6 (NAMUR)   |
| Switching point/switching hysteresis                    | 1.2 ... 2.1 mA ± 0.2 mA  |
| Line fault detection                                    | option: On/Off, for each channel<br>mechanical switches: see connection diagram<br>NAMUR proximity switches: no replacement network required<br>switching points:<br>- short circuit: typical < 360 Ω, certain < 100 Ω<br>- open circuit: typical < 0.35 mA, certain < 0.05 mA |
| Voltage   | 8.2 V, typical   |
| Internal resistor                                       | approx. 1 kΩ   |
| <b>Ambient conditions</b>                               |  |
| Ambient temperature                                     | -20 ... 60 °C (-4 ... 140 °F)  |
| Storage temperature                                     | -25 ... 85 °C (-13 ... 185 °F)   |
| <b>Mechanical specifications</b>                        |  |
| Protection degree                                       | IP20 (module), a separate housing is required acc. to the system description   |
| Mass  | approx. 350 g  |
| Dimensions  | 28 x 107 x 132 mm (1.1 x 4.2 x 5.2 in)   |
| <b>Data for application in connection with Ex-areas</b> | see page 210 for entity parameters   |
| EC-Type Examination Certificate                         | PTB 97 ATEX 1074 U, PTB 97 ATEX 1075 (system)  |
| Group, category, type of protection                     | ⊕ II 2 G Ex d II C   |
| Supply  | only in connection with the power supplies FB 92**   |
| Directive conformity                                    |  |
| Directive 94/9/EC                                       | EN 60079-0, EN 60079-1   |
| <b>International approvals</b>                          |  |
| IECEX approval  | pending  |

**Features**

- 3-channel
- Inputs wired to Ex e terminals
- Dry contact or NAMUR inputs
- Galvanic isolation between inputs and bus (group isolation)
- Installation in suitable enclosures in Zone 1 and Zone 21
- Module can be exchanged under voltage in Zone 1 (hot swap)
- Positive or negative logic selectable
- Simulation mode for service operations (forcing)
- Line fault detection (LFD)
- Permanently self-monitoring
- EMC acc. to NAMUR NE 21

**Function**

The device accepts up to 3 digital input signals of NAMUR sensors or mechanical contacts from the hazardous area. Open or short circuit line fault alarms are detected. The inputs are galvanically isolated from the bus and the power supply (EN 60079-11).

**Diagrams**

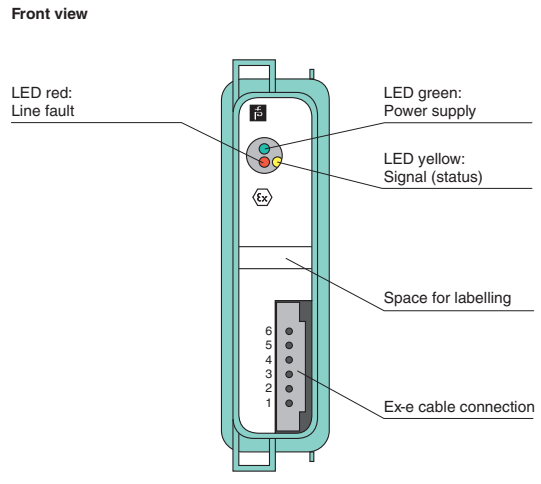
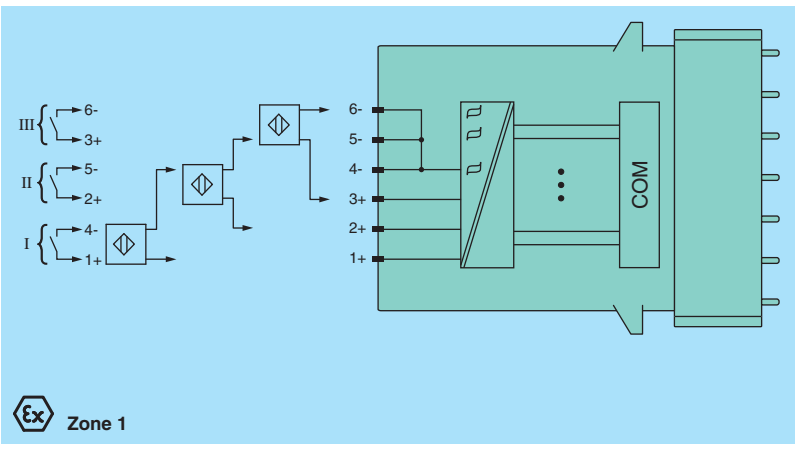

Edition 912907 (US) / 220718 (EU) 06/2011





FB-System

Digital Inputs

Digital Outputs

Analog Inputs

Analog Outputs

Bus Couplers

Power Supplies

Accessories

**Features**

- 1-channel
- Input wired to Ex e terminals
- Input for frequency, counter, direction of rotation
- Digital input max. 15 kHz
- Installation in suitable enclosures in Zone 1 and Zone 21
- Module can be exchanged under voltage in Zone 1 (hot swap)
- Positive or negative logic selectable
- Simulation mode for service operations (forcing)
- Line fault detection (LFD)
- Permanently self-monitoring
- EMC acc. to NAMUR NE 21

**Function**

The device accepts digital input signals of NAMUR sensors from the hazardous area.

Open or short circuit line fault alarms are detected.

The inputs are galvanically isolated from the bus and the power supply (EN 60079-11).

**Technical data**

|   |  |
|---|--|
| <b>Supply</b>   |  |
| Connection  | backplane bus  |
| Rated voltage   | 12 V DC, only in connection with the power supplies FB 92**  |
| Power consumption                                       | 0.6 W  |
| <b>Internal bus</b>                                     |  |
| Connection  | backplane bus  |
| Interface   | manufacturer specific bus to standard Com Unit/gateway   |
| <b>Input</b>  |  |
| Suitable sensors  | Frequency, counter, direction of rotation, NAMUR proximity switches, 2-wire initiators   |
| Connection  | wire ends 1+ (white), 2- (brown); 4+ (yellow), 5- (grey)   |
| Rated values  | acc. to EN 60947-5-6 (NAMUR)   |
| Switching point/switching hysteresis                    | 1.2 ... 2.1 mA/± 0.2 mA  |
| Line fault detection                                    | option: On/Off, for each channel<br>mechanical switches: see connection diagram<br>NAMUR proximity switches: no replacement network required<br>switching points:<br>- short circuit: typical < 360 Ω, certain < 100 Ω<br>- open circuit: typical < 0.35 mA, certain < 0.05 mA |
| Voltage   | 8.2 V, typical   |
| Internal resistor                                       | approx. 1 kΩ   |
| Operating frequency                                     | 0 ... 15 kHz   |
| <b>Ambient conditions</b>                               |  |
| Ambient temperature                                     | -20 ... 60 °C (-4 ... 140 °F)  |
| Storage temperature                                     | -25 ... 85 °C (-13 ... 185 °F)   |
| <b>Mechanical specifications</b>                        |  |
| Protection degree                                       | IP20 (module), a separate housing is required acc. to the system description   |
| Mass  | approx. 350 g  |
| Dimensions  | 28 x 107 x 132 mm (1.1 x 4.2 x 5.2 in)   |
| <b>Data for application in connection with Ex-areas</b> |  |
| EC-Type Examination Certificate                         | PTB 97 ATEX 1074 U, PTB 97 ATEX 1075 (system)  |
| Group, category, type of protection                     | ⊕ II 2 G Ex d II C   |
| Supply  | only in connection with the power supplies FB 92**   |
| <b>Directive conformity</b>                             |  |
| Directive 94/9/EC                                       | EN 60079-0, EN 60079-1   |
| <b>International approvals</b>                          |  |
| IECEX approval  | pending  |

**Diagrams**

Front view

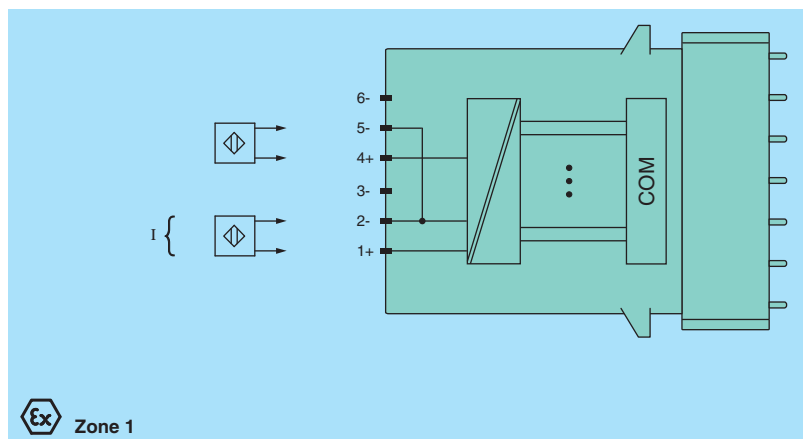
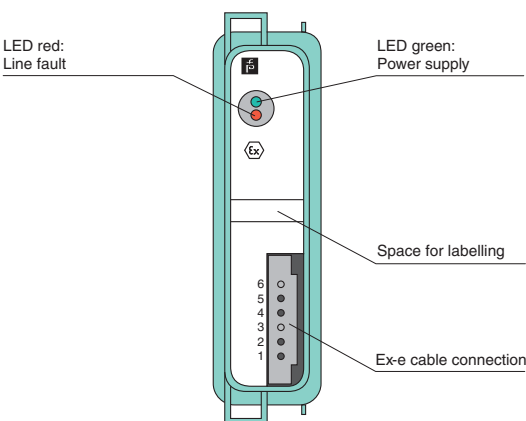

Edition 912907 (US) / 220718 (EU) 06/2011

| Technical data  |   |
|---|---|
| <b>Supply</b>   |   |
| Connection  | backplane bus   |
| Rated voltage   | 12 V DC, only in connection with the power supplies FB 92**   |
| Power consumption                                       | 0.7 W   |
| <b>Internal bus</b>                                     |   |
| Connection  | backplane bus   |
| Interface   | manufacturer specific bus to standard Com Unit/gateway  |
| <b>Input</b>  |   |
| Suitable sensors  | mechanical contacts, NAMUR proximity switches, 2-wire initiators  |
| Rated values  | acc. to EN 60947-5-6 (NAMUR)  |
| Switching point/switching hysteresis                    | 1.2 ... 2.1 mA/± 0.2 mA   |
| Line fault detection                                    | option: On/Off, for each channel<br>mechanical switches: see connection diagram<br>NAMUR proximity switches: no replacement network required<br>switching points:<br>- short circuit: typical < 360 Ω, certain < 100 Ω<br>- open circuit: typical < 0.35 mA, certain < 0.05 mA<br>switching points 24 V: ON > 8 V, OFF < 3 V<br>switching points 5 V: ON > 2.7 V, OFF < 2.3 V |
| Voltage   | 8.2 V, typical  |
| Internal resistor                                       | approx. 1 kΩ  |
| Operating frequency                                     | 0 ... 50 Hz, depending on the process control system  |
| <b>Ambient conditions</b>                               |   |
| Ambient temperature                                     | -20 ... 60 °C (-4 ... 140 °F)   |
| Storage temperature                                     | -25 ... 85 °C (-13 ... 185 °F)  |
| <b>Mechanical specifications</b>                        |   |
| Protection degree                                       | IP20 (module), a separate housing is required acc. to the system description  |
| Mass  | approx. 750 g   |
| Dimensions  | 57 x 107 x 132 mm (2.2 x 4.2 x 5.2 in)  |
| <b>Data for application in connection with Ex-areas</b> |   |
| EC-Type Examination Certificate                         | PTB 97 ATEX 1074 U, PTB 97 ATEX 1075 (system)   |
| Group, category, type of protection                     | ⊕ II 2 G Ex d II C  |
| Supply  | only in connection with the power supplies FB 92**  |
| Directive conformity                                    |   |
| Directive 94/9/EC                                       | EN 60079-0, EN 60079-1  |
| <b>International approvals</b>                          |   |
| IECEX approval  | pending   |

**Features**

- 8-channel
- Inputs wired to Ex e terminals
- Dry contact or NAMUR inputs
- Galvanic isolation between inputs and bus (group isolation)
- Installation in suitable enclosures in Zone 1 and Zone 21
- Module can be exchanged under voltage in Zone 1 (hot swap)
- Positive or negative logic selectable
- Simulation mode for service operations (forcing)
- Line fault detection (LFD)
- Permanently self-monitoring
- On/Off delay
- EMC acc. to NAMUR NE 21

**Function**

The device accepts digital input signals of NAMUR sensors or mechanical contacts from the hazardous area. Open or short circuit line fault alarms are detected. The inputs are galvanically isolated from the bus and the power supply (EN 60079-11).

**Diagrams**

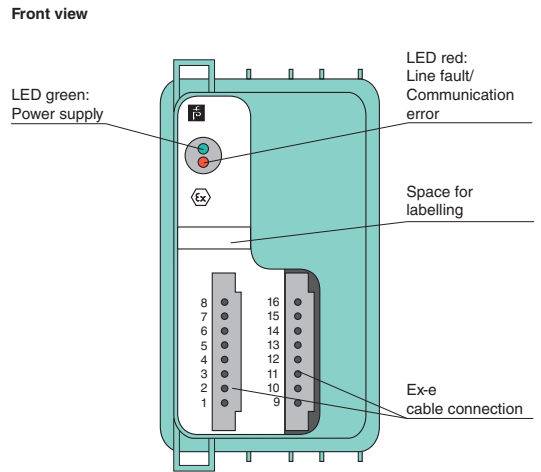
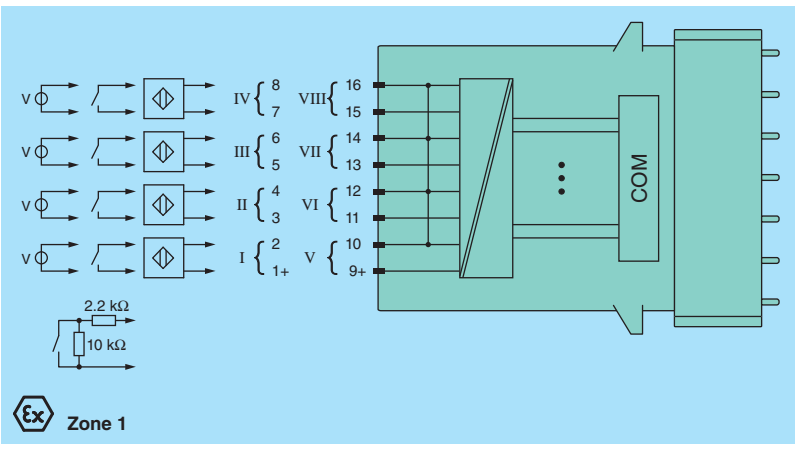

Edition 912907 (US) / 220718 (EU) 06/2011

## ATEX Entity Parameters

| Model Number | Terminals  | U <sub>o</sub> (V) | I <sub>o</sub> (mA) | P <sub>o</sub> (mW) | P <sub>D</sub> (W) |
|--------------|--|--------------------|---------------------|---------------------|--------------------|
| FB 1201 B    | 1+, 2-; 4+, 5-   | 12.6               | 12.8                | 40.1                | 0.5                |
| FB 1202 B    | 1+, 4-; 2+, 5-; 3+, 6-   | 10.5               | 35                  | 92                  | 0.5                |
| FB 1203 *    | 1+, 2-; 4+, 5-   | 10.5               | 23.3                | 61.2                | 0.6                |
| FB1208 B     | 1+, 2-; 3+, 4-; 5+, 6-; 7+, 8-;<br>9+, 10-; 11+, 12-; 13+, 14-; 15+, 16- | 14.9               | 15.7                | 58.2                | 0.8                |
| FB 1301 **   | 1+, 2-; 4+, 5-   | –                  | –                   | –                   | 0.5                |
| FB 1302 **   | 1+, 4-; 2+, 5-; 3+, 6-   | –                  | –                   | –                   | 0.5                |
| FB 1303 **   | 1+, 2-; 4+, 5-   | –                  | –                   | –                   | 0.6                |
| FB 1308 **   | 1+, 2-; 3+, 4-; 5+, 6-; 7+, 8-;<br>9+, 10-; 11+, 12-; 13+, 14-; 15+, 16- | –                  | –                   | –                   | 0.8                |

Digital Outputs with Position Feedback

| Model Number                     | Channels |        | Occupied Slots | Input (Field)      |                            | Output (Field)    |                   |                            | SIL | Input Ex ia | Output Ex ia | Mounting in Suitable Enclosures in Zone 1 and Zone 21 | Page |
|----------------------------------|----------|--------|----------------|--------------------|----------------------------|-------------------|-------------------|----------------------------|-----|-------------|--------------|---|------|
|                                  | Input    | Output |                | NAMUR/Dry Contacts | Line Fault Detection (LFD) | Electronic Output | Watchdog Function | Line Fault Detection (LFD) |     |             |              |   |      |
| FB 2201 - FB 2213 <sup>1 2</sup> | 2        | 1      | 1              | ■                  | ■                          | ■                 | ■                 | ■                          |     | ■           | ■            | ■   | 212  |
| FB 2201 - FB 2213 SIL2           | 2        | 1      | 1              | ■                  | ■                          | ■                 | ■                 | ■                          | 2   | ■           | ■            | ■   | 213  |

<sup>1</sup> FB 2212 B compatible replacement for FB 2212 D (spares available) – new gateways allow LFD test pulse to be switched off  
<sup>2</sup> FB 2213 B compatible replacement for FB 2213 D (spares available) – new gateways allow LFD test pulse to be switched off

Digital Outputs

| Model Number <sup>3</sup> | Channels | Occupied Slots | Output (Field) |                   |                   |                            | SIL | Output Ex ia | Output Ex ib | Output Ex e | Mounting in Suitable Enclosures in Zone 1 and Zone 21 | Page |
|---------------------------|----------|----------------|----------------|-------------------|-------------------|----------------------------|-----|--------------|--------------|-------------|---|------|
|                           |          |                | Relay Output   | Electronic Output | Watchdog Function | Line Fault Detection (LFD) |     |              |              |             |   |      |
| FB 6208 * <sup>4</sup>    | 8        | 2              |                | ■                 | ■                 | ■                          | 2   |              | ■            |             | ■   | 214  |
| FB 6210 - FB 6215         | 4        | 2              |                | ■                 | ■                 | ■                          |     | ■            |              |             | ■   | 215  |
| FB 6210 - FB 6215 SIL2    | 4        | 2              |                | ■                 | ■                 | ■                          | 2   | ■            |              |             | ■   | 216  |
| FB 6301 ** <sup>5</sup>   | 2        | 1              | ■              |                   | ■                 |                            |     |              |              | ■           | ■   | 217  |
| FB 6305 **                | 4        | 2              | ■              |                   | ■                 |                            |     |              |              | ■           | ■   | 218  |
| FB 6306 **                | 8        | 2              | ■              |                   | ■                 |                            |     |              |              | ■           | ■   | 219  |

<sup>3</sup> FB 6308 \* upon enquiry  
<sup>4</sup> FB 6208 B compatible replacement for FB 6208 C (spares available) – different drive voltage and IS parameters  
<sup>5</sup> FB 6301 H compatible replacement for FB 6301 B (no spares) – 230 V version includes 24 V version

Edition 912907 (US) / 220718 (EU) 06/2011



FB-System

Digital Inputs

Digital Outputs

Analog Inputs

Analog Outputs

Bus Couplers

Power Supplies

Accessories



FB-System

Digital Inputs

Digital Outputs

Analog Inputs

Analog Outputs

Bus Couplers

Power Supplies

Accessories

**Features**

- 1 digital output, 2 digital inputs
- Inputs and output Ex ia
- Installation in suitable enclosures in Zone 1 and Zone 21
- Module can be exchanged under voltage in Zone 1 (hot swap)
- Positive or negative logic selectable
- Simulation mode for service operations (forcing)
- Line fault detection (LFD)
- Permanently self-monitoring
- Output with watchdog circuit
- EMC acc. to NAMUR NE 21

**Function**

The digital output features 1 output with 2 feedback inputs.

The digital output can control a solenoid valve, a sounder or an indicator (without line fault detection) in the field. Additionally, it accepts 2 digital input signals of NAMUR sensors or mechanical contacts from the field.

Open or short circuit line fault alarms are detected.

The intrinsically safe inputs and the output are galvanically isolated from the bus and the power supply (IEC/EN 60079-11).

**Technical data**

**Supply**

|                   |   |
|-------------------|---|
| Connection        | backplane bus   |
| Rated voltage     | 12 V DC, only in connection with the power supplies FB 92** |
| Power consumption | 0.52 ... 1.8 W, depending on model                          |

**Internal bus**

|            |  |
|------------|--|
| Connection | backplane bus  |
| Interface  | manufacturer specific bus to standard Com Unit/gateway |

**Input**

|                                      |  |
|--------------------------------------|--|
| Suitable sensors                     | mechanical contacts, NAMUR proximity switches, 2-wire initiators |
| Rated values                         | acc. to EN 60947-5-6 (NAMUR)                                     |
| Switching point/switching hysteresis | 1.2 ... 2.1 mA/± 0.2 mA  |
| Voltage                              | 8.2 V, typical   |
| Internal resistor                    | approx. 1 kΩ   |
| Minimum pulse duration               | 1 ms   |

**Output**

|                        |  |
|------------------------|--|
| Suitable field devices | solenoid valves, acoustic alarms and LED indicators (without line fault detection) |
| Operating frequency    | 0 ... 50 Hz, depending on the process control system                               |
| Watchdog               | output Off 0.5 s after serious fault   |

**Ambient conditions**

|                     |                                |
|---------------------|--------------------------------|
| Ambient temperature | -20 ... 60 °C (-4 ... 140 °F)  |
| Storage temperature | -25 ... 85 °C (-13 ... 185 °F) |

**Mechanical specifications**

|                   |  |
|-------------------|--|
| Protection degree | IP20 (module), a separate housing is required acc. to the system description |
|-------------------|--|

**Mass**

|            |  |
|------------|--|
| Dimensions | approx. 350 g                          |
|            | 28 x 107 x 132 mm (1.1 x 4.2 x 5.2 in) |

**Data for application in connection with Ex-areas**

|                                 |   |
|---------------------------------|---|
| EC-Type Examination Certificate | PTB 97 ATEX 1074 U, PTB 97 ATEX 1075 (system) |
|---------------------------------|---|

|                                     |   |
|-------------------------------------|---|
| Group, category, type of protection | ⊕ II 2 (1) G Ex d [ia] IIC, [Ex iaD]<br>⊕ II 2 (1) G Ex d [ia] IIB (FB 2202 * only) |
|-------------------------------------|---|

|        |  |
|--------|--|
| Supply | only in connection with the power supplies FB 92** |
|--------|--|

**Directive conformity**

|                   |   |
|-------------------|---|
| Directive 94/9/EC | EN 60079-0, EN 60079-1, EN 60079-11, EN 60079-26, EN 61241-0, EN 61241-11 |
|-------------------|---|

**International approvals**

|                |         |
|----------------|---------|
| IECEx approval | pending |
|----------------|---------|

**Diagrams**

Front view

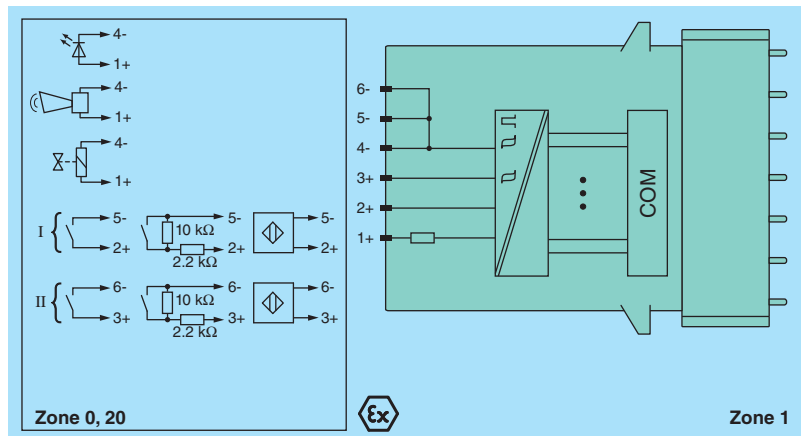
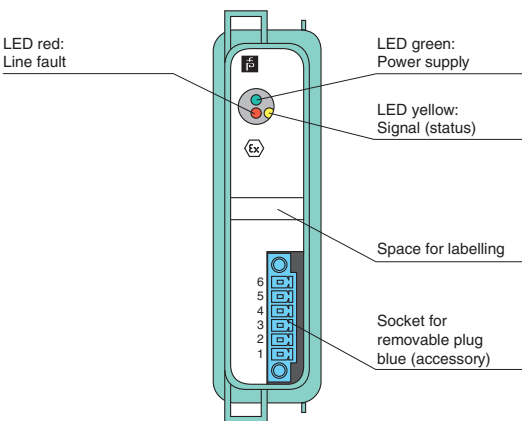

Edition 912907 (US) / 220718 (EU) 06/2011

| Technical data  |   |
|---|---|
| <b>Supply</b>   |   |
| Connection  | backplane bus   |
| Rated voltage   | 12 V DC, only in connection with the power supplies FB 92**                         |
| Power consumption                                       | 0.52 ... 1.3 W, depending on model  |
| <b>Internal bus</b>                                     |   |
| Connection  | backplane bus   |
| Interface   | manufacturer specific bus to standard Com Unit/gateway                              |
| <b>Input</b>  |   |
| Suitable sensors  | mechanical contacts, NAMUR proximity switches, 2-wire initiators                    |
| Rated values  | acc. to EN 60947-5-6 (NAMUR)  |
| Switching point/switching hysteresis                    | 1.2 ... 2.1 mA/± 0.2 mA   |
| Voltage   | 8.2 V, typical  |
| Internal resistor                                       | approx. 1 kΩ  |
| Minimum pulse duration                                  | 1 ms  |
| <b>Output</b>   |   |
| Suitable field devices                                  | solenoid valves, acoustic alarms and LED indicators (without line fault detection)  |
| Operating frequency                                     | 0 ... 50 Hz, depending on the process control system                                |
| Watchdog  | output Off 0.5 s after serious fault  |
| <b>Ambient conditions</b>                               |   |
| Ambient temperature                                     | -20 ... 60 °C (-4 ... 140 °F)   |
| Storage temperature                                     | -25 ... 85 °C (-13 ... 185 °F)  |
| <b>Mechanical specifications</b>                        |   |
| Protection degree                                       | IP20 (module), a separate housing is required acc. to the system description        |
| Mass  | approx. 350 g   |
| Dimensions  | 28 x 107 x 132 mm (1.1 x 4.2 x 5.2 in)  |
| <b>Data for application in connection with Ex-areas</b> |   |
| EC-Type Examination Certificate                         | PTB 97 ATEX 1074 U, PTB 97 ATEX 1075 (system)                                       |
| Group, category, type of protection                     | ⊕ II 2 (1) G Ex d [ia] IIC, [Ex iaD]<br>⊕ II 2 (1) G Ex d [ia] IIB (FB 2202 * only) |
| Supply  | only in connection with the power supplies FB 92**                                  |
| <b>Directive conformity</b>                             |   |
| Directive 94/9/EC                                       | EN 60079-0, EN 60079-1, EN 60079-11, EN 60079-26, EN 61241-0, EN 61241-11           |
| <b>International approvals</b>                          |   |
| IECEX approval  | pending   |

- Features**
- 1 digital output, 2 digital inputs
  - Inputs and output Ex ia
  - Installation in suitable enclosures in Zone 1 and Zone 21
  - Module can be exchanged under voltage in Zone 1 (hot swap)
  - Positive or negative logic selectable
  - Simulation mode for service operations (forcing)
  - Line fault detection (LFD)
  - Permanently self-monitoring
  - Output with watchdog circuit
  - Output with bus-independent safety input
  - EMC acc. to NAMUR NE 21
  - Up to SIL2 acc. to IEC 61508

**Function**

The digital output features 1 output with 2 feedback inputs.

The digital output can control a solenoid valve, a sounder or an indicator (without line fault detection) in the field. Additionally, it accepts 2 digital input signals of NAMUR sensors or mechanical contacts from the field.

The output can be switched off via a contact. This can be used for bus-independent safety applications. Open or short circuit line fault alarms are detected.

The intrinsically safe inputs and the output are galvanically isolated from the bus and the power supply (IEC/EN 60079-11).

**Diagrams**

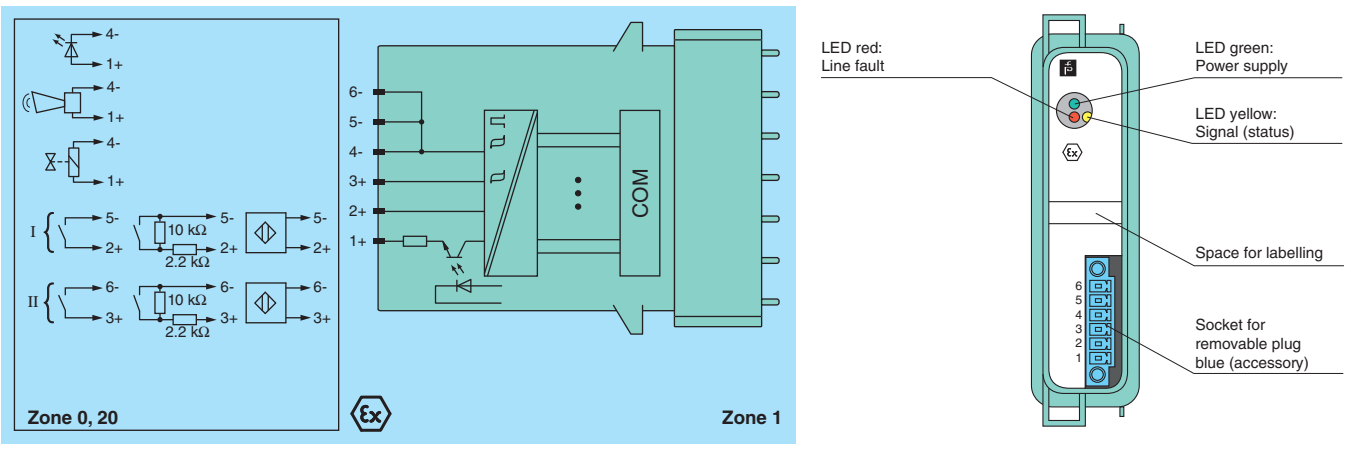

Edition 912907 (US) / 220718 (EU) 06/2011

FB-System  
Digital Inputs  
Digital Outputs  
Analog Inputs  
Analog Outputs  
Bus Couplers  
Power Supplies  
Accessories

Features

- 8-channel
- Outputs Ex ib
- Galvanic group isolation
- Installation in suitable enclosures in Zone 1 and Zone 21
- Module can be exchanged under voltage in Zone 1 (hot swap)
- Line fault detection (LFD)
- Positive or negative logic selectable
- Simulation mode for service operations (forcing)
- Permanently self-monitoring
- EMC acc. to NAMUR NE 21
- Up to SIL2 acc. to IEC 61508
- Output with watchdog circuit
- Output with bus-independent safety shutdown input

Function

The digital output features 8 independent channels.  
It can drive low power solenoids, sounders, or LEDs.  
Line faults are detected.  
The outputs are galvanically isolated from the bus and the power supply (EN 60079-11).  
The outputs can be switched off via a contact. This can be used for bus-independent safety applications.

Technical data

|   |  |
|---|--|
| <b>Supply</b>   |  |
| Connection  | backplane bus  |
| Rated voltage   | 12 V DC, only in connection with the power supplies FB 92**                            |
| Power consumption                                       | 2.2 W  |
| <b>Internal bus</b>                                     |  |
| Connection  | backplane bus  |
| Interface   | manufacturer specific bus to standard Com Unit/gateway                                 |
| <b>Output</b>   |  |
| Connection  | terminals 1+, 2/3+, 4/5+, 6/7+, 8/9+, 10/11+, 12/13+, 14/15+, 16                       |
| Watchdog  | output Off 0.5 s after serious fault   |
| Digital signals (active/short-protected)                | 20 V, 8 mA (model FB 6208 B) per channel, 21.6 V, 5.2 mA (model FB 6208 C) per channel |
| Sampling time   | 6.5 ms   |
| LFD test current  | 0.33 mA  |
| <b>Ambient conditions</b>                               |  |
| Ambient temperature                                     | -20 ... 60 °C (-4 ... 140 °F)  |
| Storage temperature                                     | -25 ... 85 °C (-13 ... 185 °F)   |
| <b>Mechanical specifications</b>                        |  |
| Protection degree                                       | IP20 (module), a separate housing is required acc. to the system description           |
| Mass  | approx. 750 g  |
| Dimensions  | 57 x 107 x 132 mm (2.2 x 4.2 x 5.2 in)   |
| <b>Data for application in connection with Ex-areas</b> | see page 220 for entity parameters   |
| EC-Type Examination Certificate                         | PTB 97 ATEX 1074 U, PTB 97 ATEX 1075 (system)  |
| Group, category, type of protection                     | ⊕ II 2 G Ex d [ib] IIC, [Ex ibD]   |
| Supply  | only in connection with the power supplies FB 92**                                     |
| Directive conformity                                    |  |
| Directive 94/9/EC                                       | EN 60079-0, EN 60079-11, EN 60079-15, EN 61241-0, EN 61241-11                          |
| <b>International approvals</b>                          |  |
| IECEx approval  | pending  |

Diagrams

Front view

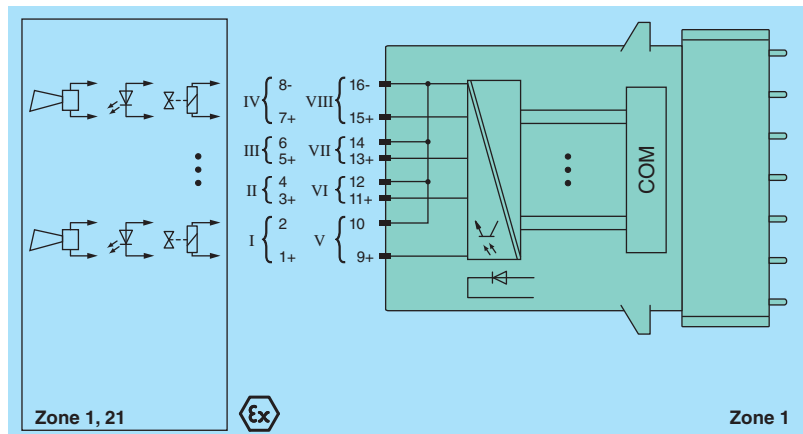
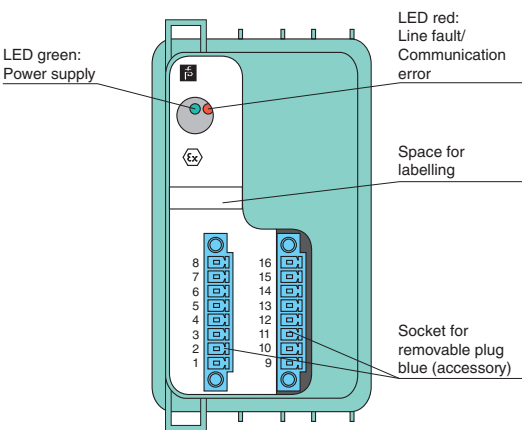

Edition 912907 (US) / 220718 (EU) 06/2011



**Technical data**

|   |  |
|---|--|
| <b>Supply</b>   |  |
| Connection  | backplane bus/24 V booster via wire ends                                     |
| Rated voltage   | 12 V DC, only in connection with the power supplies FB 92**                  |
| Power consumption                                       | 0.6 W/5 W  |
| <b>Internal bus</b>                                     |  |
| Connection  | backplane bus  |
| Interface   | manufacturer specific bus to standard Com Unit/gateway                       |
| <b>Output</b>   |  |
| Response time   | 10 ms (depending on master)  |
| Watchdog  | output Off 0.5 s after serious fault   |
| Sampling time   | 6.5 ms   |
| LFD test pulse  | every 2.5 s for 2 ms   |
| <b>Ambient conditions</b>                               |  |
| Ambient temperature                                     | -20 ... 60 °C (-4 ... 140 °F)  |
| Storage temperature                                     | -25 ... 85 °C (-13 ... 185 °F)   |
| <b>Mechanical specifications</b>                        |  |
| Protection degree                                       | IP20 (module), a separate housing is required acc. to the system description |
| Connection  | via backplane  |
| Mass  | approx. 750 g  |
| Dimensions  | 57 x 107 x 132 mm (2.2 x 4.2 x 5.2 in)                                       |
| <b>Data for application in connection with Ex-areas</b> | see page 220 for entity parameters   |
| EC-Type Examination Certificate                         | PTB 97 ATEX 1074 U, PTB 97 ATEX 1075 (system)                                |
| Group, category, type of protection                     | ⊕ II 2 (1) G Ex d [ia] IIC, [Ex iaD]   |
| Supply  | only in connection with the power supplies FB 92**                           |
| Directive conformity                                    |  |
| Directive 94/9/EC                                       | EN 60079-0, EN 60079-1, EN 60079-11, EN 60079-26, EN 61241-0, EN 61241-11    |
| <b>International approvals</b>                          |  |
| IECEX approval  | pending  |

**Features**

- 4-channel
- Outputs Ex ia
- Device installation in suitable enclosures in Zone 1 and Zone 21
- Line fault detection (LFD)
- Module can be exchanged under voltage in Zone 1 (hot swap)
- Positive or negative logic selectable
- Simulation mode for service operations (forcing)
- Permanently self-monitoring
- Output with watchdog circuit
- EMC acc. to NAMUR NE 21

**Function**

The digital output features 4 independent channels. It can drive solenoids, sounders, or LEDs. Line faults are detected. The outputs are galvanically isolated from the bus and the power supply (EN 60079-11).

**Diagrams**

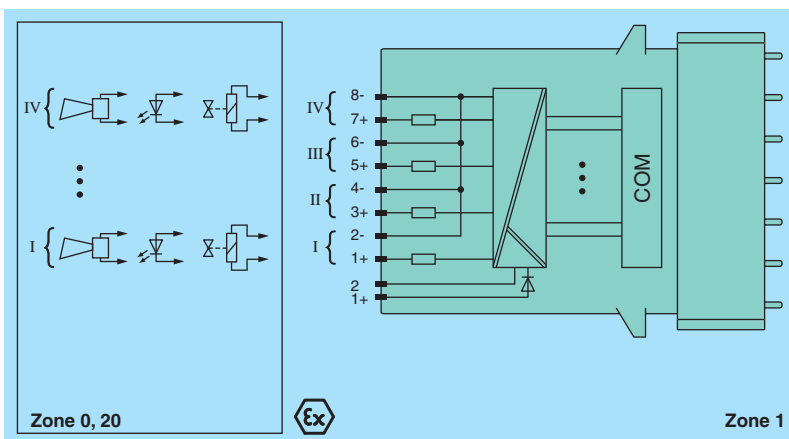

Front view

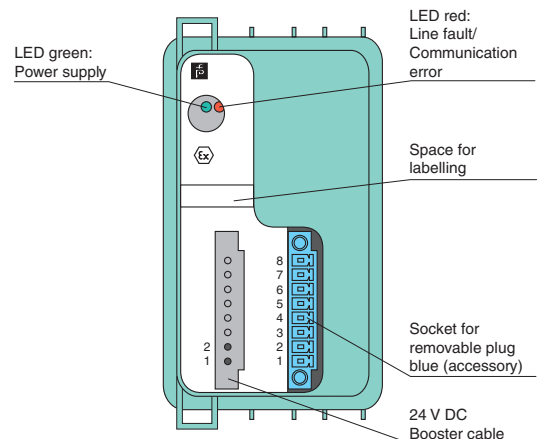

Edition 912907 (US) / 220718 (EU) 06/2011

Subject to modifications without notice

Pepperl+Fuchs Group  
www.pepperl-fuchs.com

USA: +1 330 486 0002  
pa-info@us.pepperl-fuchs.com

Germany: +49 621 776 2222  
pa-info@de.pepperl-fuchs.com

Copyright Pepperl+Fuchs  
Singapore: +65 6779 9091  
pa-info@sg.pepperl-fuchs.com





FB-System

Digital Inputs

Digital Outputs

Analog Inputs

Analog Outputs

Bus Couplers

Power Supplies

Accessories



**Features**

- 4-channel
- Outputs Ex ia
- Device installation in suitable enclosures in Zone 1 and Zone 21
- Module can be exchanged under voltage in Zone 1 (hot swap)
- Line fault detection (LFD)
- Positive or negative logic selectable
- Simulation mode for service operations (forcing)
- Permanently self-monitoring
- Output with watchdog circuit
- Up to SIL2 acc. to IEC 61508
- Output with bus-independent safety shutdown input
- EMC acc. to NAMUR NE 21

**Function**

The digital output features 4 independent channels.

It can drive solenoids, sounders, or LEDs. Line faults are detected.

The outputs are galvanically isolated from the bus and the power supply (EN 60079-11).

The output can be switched off via a contact. This can be used for bus-independent safety applications.

**Technical data**

**Supply**

|               |   |
|---------------|---|
| Connection    | backplane bus/booster terminals                             |
| Rated voltage | 12 V DC, only in connection with the power supplies FB 92** |

|                   |           |
|-------------------|-----------|
| Power consumption | 0.6 W/5 W |
|-------------------|-----------|

**Internal bus**

|            |   |
|------------|---|
| Connection | backplane bus   |
| Interface  | manufacturer specific bus to standard ComUnit/Gateway |

**Output**

|                |                                      |
|----------------|--------------------------------------|
| Response time  | 10 ms (depending on master)          |
| Watchdog       | output OFF 0.5 s after serious fault |
| Sampling time  | 6.5 ms                               |
| LFD test pulse | every 2.5 s for 2 ms                 |

**Ambient conditions**

|                     |                                |
|---------------------|--------------------------------|
| Ambient temperature | -20 ... 60 °C (-4 ... 140 °F)  |
| Storage temperature | -25 ... 85 °C (-13 ... 185 °F) |

**Mechanical specifications**

|                   |  |
|-------------------|--|
| Protection degree | IP20 (module), a separate housing is required acc. to the system description |
|-------------------|--|

|            |  |
|------------|--|
| Mass       | approx. 750 g                          |
| Dimensions | 57 x 107 x 132 mm (2.2 x 4.2 x 5.2 in) |

**Data for application in connection with Ex-areas**

|                                     |   |
|-------------------------------------|---|
| EC-Type Examination Certificate     | PTB 97 ATEX 1074 U, PTB 97 ATEX 1075 (system) |
| Group, category, type of protection | ⊕ II 2 (1) G Ex d [ia] IIC, [Ex iaD]          |

|        |  |
|--------|--|
| Supply | only in connection with the power supplies FB 92** |
|--------|--|

**Directive conformity**

|                   |   |
|-------------------|---|
| Directive 94/9/EC | EN 60079-0, EN 60079-1, EN 60079-11, EN 60079-26, EN 61241-0, EN 61241-11 |
|-------------------|---|

**International approvals**

|                |         |
|----------------|---------|
| IECEx approval | pending |
|----------------|---------|

**Diagrams**

Front view

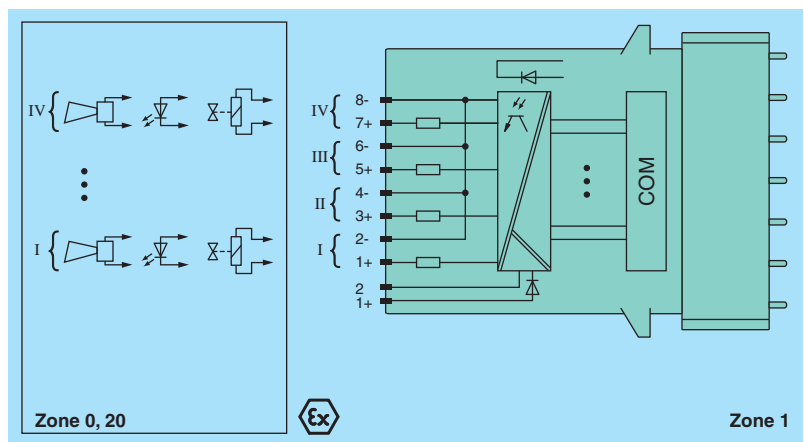
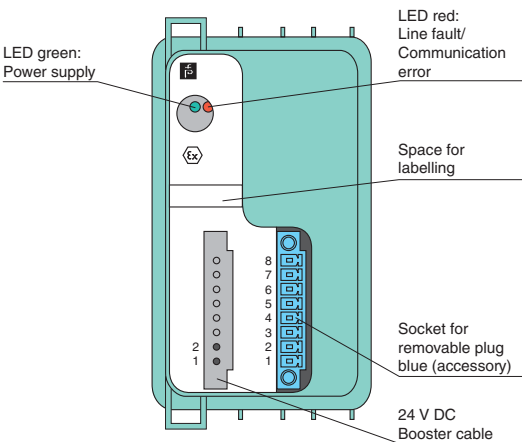

Edition 912907 (US) / 220718 (EU) 06/2011

| Technical data  |  |
|---|--|
| <b>Supply</b>   |  |
| Connection  | backplane bus  |
| Rated voltage   | 12 V DC, only in connection with the power supplies FB 92**                  |
| Power consumption                                       | 0.65 W   |
| <b>Internal bus</b>                                     |  |
| Connection  | backplane bus  |
| Interface   | manufacturer specific bus to standard Com Unit/gateway                       |
| <b>Output</b>   |  |
| Connection  | wire ends 1 (white), 2 (brown), 3 (green), 4 (yellow), 5 (grey), 6 (pink)    |
| Switching voltage                                       | nominal 24 V DC/230 V AC   |
| Switching current                                       | 1 A, AC/DC, resistive load   |
| Switch power  | 30 W, 230 VA resistive load  |
| Response time   | approx. 20 ms (depending on bus cycle time)                                  |
| Electrical life   | 0.5 mio. cycles  |
| Minimal switching capability                            | ≥ 1 V, ≥ 1 mA  |
| Contact Material  | AgPd gold plated   |
| Watchdog  | output Off 0.5 s after serious fault   |
| Sampling time   | approx. 6.5 ms   |
| <b>Ambient conditions</b>                               |  |
| Ambient temperature                                     | -20 ... 60 °C (-4 ... 140 °F)  |
| Storage temperature                                     | -25 ... 85 °C (-13 ... 185 °F)   |
| <b>Mechanical specifications</b>                        |  |
| Protection degree                                       | IP20 (module), a separate housing is required acc. to the system description |
| Mass  | approx. 350 g  |
| Dimensions  | 28 x 107 x 132 mm (1.1 x 4.2 x 5.2 in)                                       |
| <b>Data for application in connection with Ex-areas</b> |  |
| EC-Type Examination Certificate                         | PTB 97 ATEX 1074 U, PTB 97 ATEX 1075 (system)                                |
| Group, category, type of protection                     | ⊕ II 2 G Ex d II C   |
| Supply  | only in connection with the power supplies FB 92**                           |
| <b>Directive conformity</b>                             |  |
| Directive 94/9/EC                                       | EN 60079-0, EN 60079-1   |
| <b>International approvals</b>                          |  |
| IECEx approval  | pending  |

**Features**

- 2-channel
- Outputs wired to Ex e terminals
- Device installation in suitable enclosures in Zone 1 and Zone 21
- Module can be exchanged under voltage in Zone 1 (hot swap)
- Positive or negative logic selectable
- Simulation mode for service operations (forcing)
- Permanently self-monitoring
- Output with watchdog circuit
- EMC acc. to NAMUR NE 21

**Function**

The relay output features 2 independent channels.

The relay output can be used to switch solenoids, sounders, or lamps.

It can also perform general switching operations, e.g. to switch auxiliary power circuits.

The outputs are galvanically isolated from the bus and the power supply (EN 61010-1).

This module is a fully compatible replacement for FB 6301B\*.

**Diagrams**

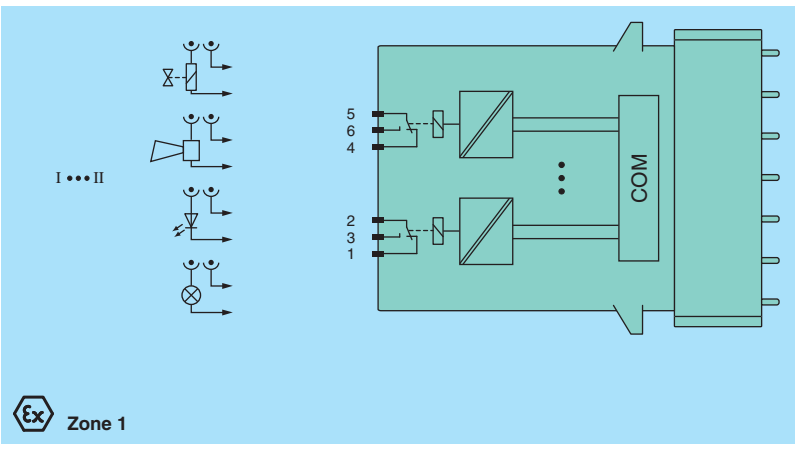

Front view

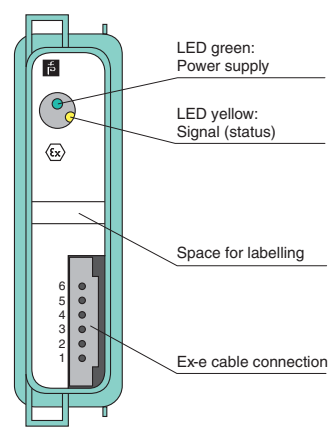

Edition 912907 (US) / 220718 (EU) 06/2011

Subject to modifications without notice

Pepperl+Fuchs Group  
www.pepperl-fuchs.com

USA: +1 330 486 0002  
pa-info@us.pepperl-fuchs.com

Germany: +49 621 776 2222  
pa-info@de.pepperl-fuchs.com

Copyright Pepperl+Fuchs  
Singapore: +65 6779 9091  
pa-info@sg.pepperl-fuchs.com

FB-System

Digital Inputs

Digital Outputs

Analog Inputs

Analog Outputs

Bus Couplers

Power Supplies

Accessories

**Features**

- 4-channel
- Outputs wired to Ex e terminals
- Installation in suitable enclosures in Zone 1 and Zone 21
- Module can be exchanged under voltage in Zone 1 (hot swap)
- Positive or negative logic selectable
- Output with watchdog circuit
- Simulation mode for service operations (forcing)
- Permanently self-monitoring
- EMC acc. to NAMUR NE 21

**Function**

The relay output features 4 independent channels.

The relay output can be used to switch solenoids, sounders, or lamps.

It can also perform general switching operations, e.g. to switch auxiliary power circuits.

The outputs are galvanically isolated from the bus and the power supply (EN 61010-1).

**Technical data**

**Supply**

|                   |   |
|-------------------|---|
| Connection        | backplane bus   |
| Rated voltage     | 12 V DC, only in connection with the power supplies FB 92** |
| Power consumption | 1.2 W   |

**Internal bus**

|            |  |
|------------|--|
| Connection | backplane bus  |
| Interface  | manufacturer specific bus to standard Com Unit/gateway |

**Output**

|            |   |
|------------|---|
| Connection | wire ends 1/9 (white), 2/10 (brown), 3/11 (green), 4/12 (yellow), 5/13 (grey), 6/14 (pink), 7/15 (blue), 8/16 (red) |
|------------|---|

|                              |   |
|------------------------------|---|
| Switching voltage            | 30 V DC, 230 V AC                           |
| Switching current            | 1 A, AC/DC, resistive load                  |
| Switch power                 | 30 W, 230 VA                                |
| Response time                | approx. 20 ms (depending on bus cycle time) |
| Electrical life              | 0.1 mio. cycles                             |
| Minimal switching capability | ≥ 1 V, ≥ 1 mA                               |
| Contact Material             | AgPd gold plated                            |
| Watchdog                     | output Off 0.5 s after serious fault        |
| Sampling time                | approx. 6.5 ms                              |

**Ambient conditions**

|                     |                                |
|---------------------|--------------------------------|
| Ambient temperature | -20 ... 60 °C (-4 ... 140 °F)  |
| Storage temperature | -25 ... 85 °C (-13 ... 185 °F) |

**Mechanical specifications**

|                   |  |
|-------------------|--|
| Protection degree | IP20 (module), a separate housing is required acc. to the system description |
|-------------------|--|

|            |  |
|------------|--|
| Mass       | approx. 750 g                          |
| Dimensions | 57 x 107 x 132 mm (2.2 x 4.2 x 5.2 in) |

**Data for application in connection with Ex-areas** see page 220 for entity parameters

|                                     |   |
|-------------------------------------|---|
| EC-Type Examination Certificate     | PTB 97 ATEX 1074 U, PTB 97 ATEX 1075 (system) |
| Group, category, type of protection | ⊕ II 2 G Ex d II C                            |

|        |  |
|--------|--|
| Supply | only in connection with the power supplies FB 92** |
|--------|--|

|                      |                        |
|----------------------|------------------------|
| Directive conformity | Directive 94/9/EC      |
|                      | EN 60079-0, EN 60079-1 |

**International approvals**

|                |         |
|----------------|---------|
| IECEx approval | pending |
|----------------|---------|

**Diagrams**

Front view

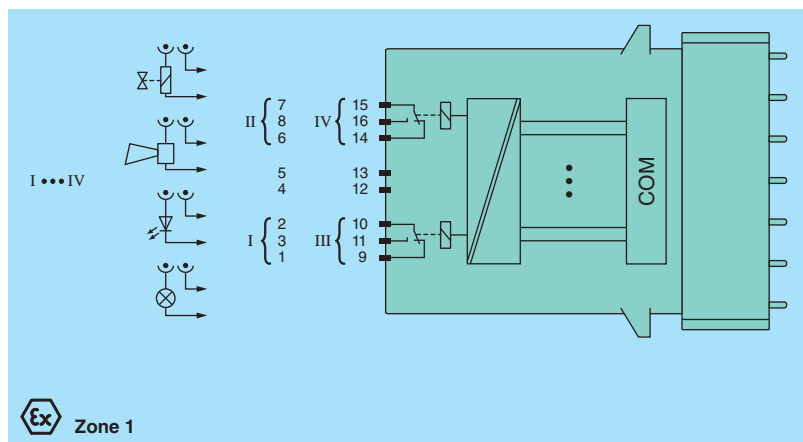
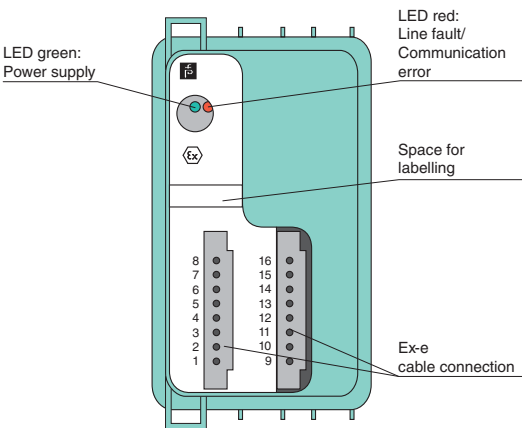

Edition 912907 (US) / 220718 (EU) 06/2011

| Technical data  |   |
|---|---|
| <b>Supply</b>   |   |
| Connection  | backplane bus   |
| Rated voltage   | 12 V DC, only in connection with the power supplies FB 92**   |
| Power consumption                                       | 1.6 W   |
| <b>Internal bus</b>                                     |   |
| Connection  | backplane bus   |
| Interface   | manufacturer specific bus to standard Com Unit/gateway  |
| <b>Output</b>   |   |
| Connection  | wire ends 1/9 (white), 2/10 (brown), 3/11 (green), 4/12 (yellow), 5/13 (grey), 6/14 (pink), 7/15 (blue), 8/16 (red) |
| Switching voltage                                       | 24 V DC, 24 V AC  |
| Switching current                                       | 1 A, AC/DC, resistive load  |
| Switch power  | 30 W, 30 VA   |
| Response time   | approx. 20 ms (depending on bus cycle time)   |
| Electrical life   | 0.5 mio. cycles   |
| Minimal switching capability                            | ≥ 1 V, ≥ 1 mA   |
| Contact Material  | AgPd gold plated  |
| Watchdog  | output Off 0.5 s after serious fault  |
| Sampling time   | approx. 6.5 ms  |
| <b>Ambient conditions</b>                               |   |
| Ambient temperature                                     | -20 ... 60 °C (-4 ... 140 °F)   |
| Storage temperature                                     | -25 ... 85 °C (-13 ... 185 °F)  |
| <b>Mechanical specifications</b>                        |   |
| Protection degree                                       | IP20 (module), a separate housing is required acc. to the system description  |
| Mass  | approx. 750 g   |
| Dimensions  | 57 x 107 x 132 mm (2.2 x 4.2 x 5.2 in)  |
| <b>Data for application in connection with Ex-areas</b> |   |
| EC-Type Examination Certificate                         | PTB 97 ATEX 1074 U, PTB 97 ATEX 1075 (system)   |
| Group, category, type of protection                     | ⊕ II 2 G Ex d II C  |
| Supply  | only in connection with the power supplies FB 92**  |
| <b>Directive conformity</b>                             |   |
| Directive 94/9/EC                                       | EN 60079-0, EN 60079-1  |
| <b>International approvals</b>                          |   |
| IECEX approval  | pending   |

Features

- 8-channel
- Outputs wired to Ex e terminals
- Installation in suitable enclosures in Zone 1 and Zone 21
- Module can be exchanged under voltage in Zone 1 (hot swap)
- Line fault detection (LFD)
- Positive or negative logic selectable
- Simulation mode for service operations (forcing)
- Permanently self-monitoring
- Output with watchdog circuit
- EMC acc. to NAMUR NE 21

Function

The relay output features 8 independent channels.

The relay output can be used to switch solenoids, sounders, or lamps.

It can also perform general switching operations, e.g. to switch auxiliary power circuits.

The outputs are galvanically isolated from the bus and the power supply (EN 61010-1).

Diagrams

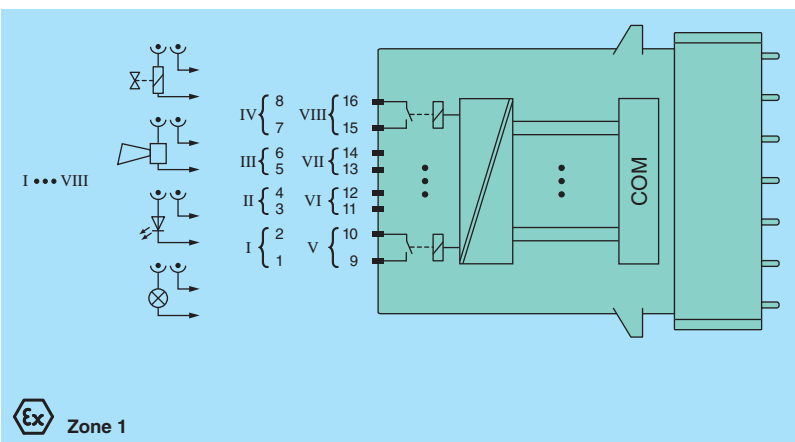

Front view

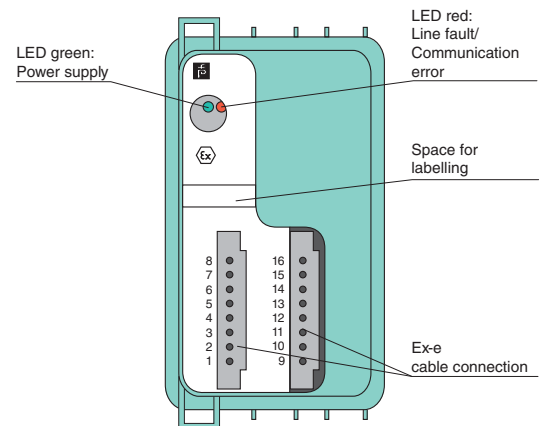

Edition 912907 (US) / 220718 (EU) 06/2011

Subject to modifications without notice

Pepperl+Fuchs Group  
www.pepperl-fuchs.com

USA: +1 330 486 0002  
pa-info@us.pepperl-fuchs.com

Germany: +49 621 776 2222  
pa-info@de.pepperl-fuchs.com

Copyright Pepperl+Fuchs  
Singapore: +65 6779 9091  
pa-info@sg.pepperl-fuchs.com

**PEPPERL+FUCHS 219**  
PROTECTING YOUR PROCESS



FB-System

Digital Inputs

Digital Outputs

Analog Inputs

Analog Outputs

Bus Couplers

Power Supplies

Accessories

## ATEX Entity Parameters

| Model Number | Terminals                             | U <sub>o</sub> (V) | I <sub>o</sub> (mA) | P <sub>o</sub> (mW) | P <sub>D</sub> (W) |
|--------------|---------------------------------------|--------------------|---------------------|---------------------|--------------------|
| FB 2201      | 1+, 4-                                | 24.9               | 91                  | 558                 | 1.05               |
|              | 2+, 5-; 3+, 6-                        | 14                 | 16                  | 55                  |                    |
| FB 2202      | 1+, 4-                                | 27.8               | 183                 | 1270                | 1.05               |
|              | 2+, 5-; 3+, 6-                        | 14                 | 16                  | 55                  |                    |
| FB 2203      | 1+, 4-                                | 27.8               | 91.5                | 636                 | 1.05               |
|              | 2+, 5-; 3+, 6-                        | 14                 | 16                  | 55                  |                    |
| FB 2204      | 1+, 4-                                | 24.2               | 145                 | 872                 | 1.05               |
|              | 2+, 5-; 3+, 6-                        | 14                 | 16                  | 55                  |                    |
| FB 2205      | 1+, 4-                                | 25.2               | 108                 | 681                 | 1.05               |
|              | 2+, 5-; 3+, 6-                        | 14                 | 16                  | 55                  |                    |
| FB 2212      | 1+, 4-                                | 27.8               | 108                 | 751                 | 1.05               |
|              | 2+, 5-; 3+, 6-                        | 14                 | 16                  | 55                  |                    |
| FB 2213      | 1+, 4-                                | 28.7               | 68                  | 485                 | 1.05               |
|              | 2+, 5-; 3+, 6-                        | 14                 | 16                  | 55                  |                    |
| FB 6208 B    | 1+, 2-; 3+, 4-; 5+, 6-; 7+, 8-;       | 28                 | 13.5                | 376                 | 1.2                |
|              | 9+, 10-; 11+, 12-; 13+, 14-; 15+, 16- |                    |                     |                     |                    |
| FB 6208 C    | 1+, 2-; 3+, 4-; 5+, 6-; 7+, 8-;       | 30                 | 13.5                | 404                 | 1.2                |
|              | 9+, 10-; 11+, 12-; 13+, 14-; 15+, 16- |                    |                     |                     |                    |
| FB 6210      | 1+, 2-; 3+, 4-; 5+, 6-; 7+, 8-        | 27.8               | 90.4                | 629                 | 3.5                |
| FB 6211      | 1+, 2-; 3+, 4-; 5+, 6-; 7+, 8-        | 27.8               | 107                 | 744                 | 3.5                |
| FB 6212      | 1+, 2-; 3+, 4-; 5+, 6-; 7+, 8-        | 19.8               | 142                 | 705                 | 3.5                |
| FB 6213      | 1+, 2-; 3+, 4-; 5+, 6-; 7+, 8-        | 26                 | 110                 | 714                 | 3.5                |
| FB 6214      | 1+, 2-; 3+, 4-; 5+, 6-; 7+, 8-        | 26                 | 88.7                | 578                 | 3.5                |
| FB 6215      | 1+, 2-; 3+, 4-; 5+, 6-; 7+, 8-        | 18.9               | 286                 | 1351                | 3.5                |
| FB 6301 **   | 1, 2, 3; 4, 5, 6                      | -                  | -                   | -                   | 1.2                |
| FB 6305 **   | 1, 2, 3; 4, 5, 6                      | -                  | -                   | -                   | 1.4                |
| FB 6306 **   | 1, 2, 3; 4, 5, 6                      | -                  | -                   | -                   | 1.6                |

## Analog Inputs – Transmitter Power Supplies

| Model Number             | Channels | Occupied Slots | Input (Field)              |                            | Supply Voltage at 20 mA | HART          |                     |                     | Input Ex ia | Input Ex e | Mounting in Suitable Enclosures in Zone 1 and Zone 21 | Page |
|--------------------------|----------|----------------|----------------------------|----------------------------|-------------------------|---------------|---------------------|---------------------|-------------|------------|---|------|
|                          |          |                | 2- and 4-wire Transmitters | Line Fault Detection (LFD) |                         | Communication | Secondary Variables | 4-wire Transmitters |             |            |   |      |
| FB 3202 B <sup>1 2</sup> | 1        | 1              | ■                          | ■                          | 16 V                    | ■             | ■                   | ■                   | ■           |            | ■   | 222  |
| FB 3205 B <sup>3</sup>   | 4        | 2              | ■                          | ■                          | 15 V                    | ■             |                     |                     | ■           |            | ■   | 223  |
| FB 3302 **               | 1        | 1              | ■                          | ■                          | 16 V                    | ■             | ■                   | ■                   |             | ■          | ■   | 224  |
| FB 3305 **               | 4        | 2              | ■                          | ■                          | 15 V                    | ■             |                     |                     |             | ■          | ■   | 225  |

<sup>1</sup> FB 3202 B compatible replacement for FB 3201 B (spares available) – different IS parameters, added HART function <sup>4</sup>

<sup>2</sup> FB 3202 B compatible replacement for FB 3203 B (spares available) – different IS parameters <sup>4</sup>

<sup>3</sup> FB 3205 B compatible replacement for FB 3204 B (spares available) – same IS parameters, added HART function <sup>4</sup>

<sup>4</sup> Replacements require configuration changes in existing installations. This can be done in a running system as it does not affect communications with the master (HCiR).

## Analog Inputs – Temperature, Voltage Converters

| Model Number | Channels | Occupied Slots | Input (Field)              |     |    |    | Line Fault Detection (LFD) | Input Ex ia | Mounting in Suitable Enclosures in Zone 1 and Zone 21 | Page |
|--------------|----------|----------------|----------------------------|-----|----|----|----------------------------|-------------|---|------|
|              |          |                | 2-, 3-, and 4-wire Sensors | RTD | TC | mV |                            |             |   |      |
| FB 5201 B    | 1        | 1              | ■                          | ■   |    |    | ■                          | ■           | ■   | 226  |
| FB 5202 B    | 1        | 1              |                            |     | ■  | ■  | ■                          | ■           | ■   | 227  |
| FB 5204 B    | 4        | 2              | ■                          | ■   |    |    | ■                          | ■           | ■   | 228  |
| FB 5205 B    | 4        | 2              |                            |     | ■  | ■  | ■                          | ■           | ■   | 229  |
| FB 5206 B    | 1        | 1              |                            |     |    | ■  | ■                          | ■           | ■   | 230  |



FB-System

Digital Inputs

Digital Outputs

Analog Inputs

Analog Outputs

Bus Couplers

Power Supplies

Accessories



FB-System

Digital Inputs

Digital Outputs

Analog Inputs

Analog Outputs

Bus Couplers

Power Supplies

Accessories

**Features**

- 1-channel
- Input Ex ia
- Power supply for 2- or 3-wire transmitters with 4 mA ... 20 mA
- Supply circuit 16.5 V (20 mA)
- Input from active signals of 4-wire transmitters
- Installation in suitable enclosures in Zone 1 and Zone 21
- HART communication via field bus or service bus
- HART communication also for separately powered devices
- Module can be exchanged under voltage in Zone 1 (hot swap)
- Simulation mode for service operations (forcing)
- Line fault (LFD) and Live Zero detection
- Permanently self-monitoring
- EMC acc. to NAMUR NE 21

**Function**

The transmitter power supply feeds 2- and 3-wire transmitters.

Active signals from separately powered field devices and 4-wire transmitters can be connected.

Open and short circuit line fault alarms as well as Live Zero status are detected.

The intrinsically safe input is galvanically isolated from the bus and the power supply (EN 60079-11).

**Technical data**

**Supply**

|               |   |
|---------------|---|
| Connection    | backplane bus   |
| Rated voltage | 12 V DC, only in connection with the power supplies FB 92** |

|                   |               |
|-------------------|---------------|
| Power consumption | approx. 1.2 W |
|-------------------|---------------|

**Internal bus**

|            |  |
|------------|--|
| Connection | backplane bus  |
| Interface  | manufacturer specific bus to standard Com Unit/gateway |

**Input**

|                        |  |
|------------------------|--|
| Suitable field devices | pressure transmitters, differential pressure transmitters, level transmitters, flowmeters etc. |
|------------------------|--|

|            |   |
|------------|---|
| Connection | terminals 2+, 5- (HART supply), terminals 5+, 6- (input), 1+, 6- (HART input) |
|------------|---|

|                  |   |
|------------------|---|
| Input resistance | 15 Ω (terminals 5, 6)<br>236 Ω (terminals 1, 6), HART |
|------------------|---|

|                            |  |
|----------------------------|--|
| Transmitter supply voltage | min. 16 V at 20 mA (incl. 250 Ω HART communication resistor) |
|----------------------------|--|

|                 |  |
|-----------------|--|
| Lead monitoring | Parameterization range 0 ... 26 mA<br>Ex works settings: line fault < 0.5 mA;<br>short circuit > 22 mA |
|-----------------|--|

|                      |                             |
|----------------------|-----------------------------|
| Live Zero monitoring | Ex works settings: ≤ 3.6 mA |
|----------------------|-----------------------------|

**Ambient conditions**

|                     |                               |
|---------------------|-------------------------------|
| Ambient temperature | -20 ... 60 °C (-4 ... 140 °F) |
|---------------------|-------------------------------|

|                     |                                |
|---------------------|--------------------------------|
| Storage temperature | -25 ... 85 °C (-13 ... 185 °F) |
|---------------------|--------------------------------|

**Mechanical specifications**

|                   |  |
|-------------------|--|
| Protection degree | IP20 (module), a separate housing is required acc. to the system description |
|-------------------|--|

|      |               |
|------|---------------|
| Mass | approx. 350 g |
|------|---------------|

|            |  |
|------------|--|
| Dimensions | 28 x 107 x 132 mm (1.1 x 4.2 x 5.2 in) |
|------------|--|

|   |                                    |
|---|------------------------------------|
| <b>Data for application in connection with Ex-areas</b> | see page 231 for entity parameters |
|---|------------------------------------|

|                                 |   |
|---------------------------------|---|
| EC-Type Examination Certificate | PTB 97 ATEX 1074 U, PTB 97 ATEX 1075 (system) |
|---------------------------------|---|

|                                     |                                      |
|-------------------------------------|--------------------------------------|
| Group, category, type of protection | ⊕ II 2 (1) G Ex d [ia] IIC, [Ex iaD] |
|-------------------------------------|--------------------------------------|

|        |  |
|--------|--|
| Supply | only in connection with the power supplies FB 92** |
|--------|--|

**Directive conformity**

|                   |   |
|-------------------|---|
| Directive 94/9/EC | EN 60079-0, EN 60079-1, EN 60079-11, EN 60079-26, EN 61241-0, EN 61241-11 |
|-------------------|---|

**International approvals**

|                |         |
|----------------|---------|
| IECEx approval | pending |
|----------------|---------|

**Diagrams**

Front view

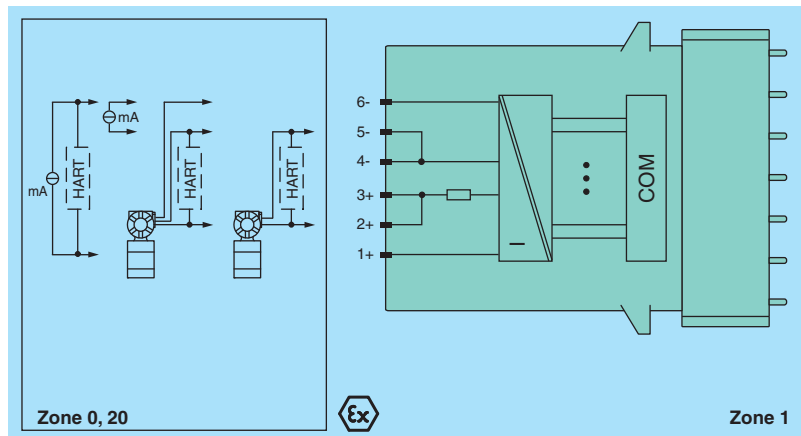
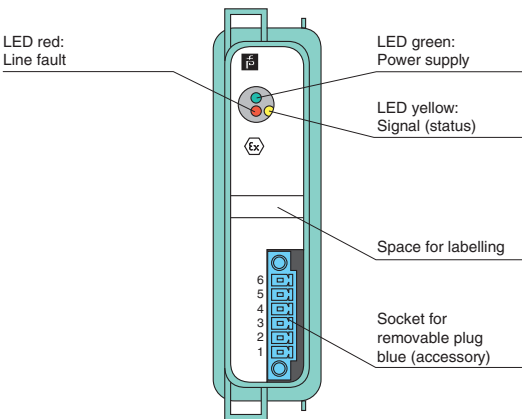

Edition 912907 (US) / 220718 (EU) 06/2011

**Technical data**

|   |   |
|---|---|
| <b>Supply</b>   |   |
| Connection  | backplane bus   |
| Rated voltage   | 12 V DC, only in connection with the power supplies FB 92**   |
| Power consumption                                       | 3 W   |
| <b>Internal bus</b>                                     |   |
| Connection  | backplane bus   |
| Interface   | manufacturer specific bus to standard Com Unit/gateway  |
| <b>Input</b>  |   |
| Suitable field devices                                  | pressure transmitters, differential pressure transmitters, level transmitters, flowmeters etc.                                    |
| Connection  | terminals 1+, 2-/5+, 6-/9+, 10 -/13 +, 14 - HART supply circuit<br>terminals 3+, 4-/7+, 8-/11+, 12-/15+, 16- active field devices |
| Input resistance  | 15 Ω (stat.), no HART for separately powered field devices  |
| Transmitter supply voltage                              | min. 15 V at 20 mA  |
| Lead monitoring   | Parameterization range 0 ... 26 mA<br>Ex works settings: line fault < 0.5 mA;<br>short circuit > 22 mA                            |
| Live Zero monitoring                                    | Ex works settings: ≤ 3.6 mA   |
| <b>Ambient conditions</b>                               |   |
| Ambient temperature                                     | -20 ... 60 °C (-4 ... 140 °F)   |
| Storage temperature                                     | -25 ... 85 °C (-13 ... 185 °F)  |
| <b>Mechanical specifications</b>                        |   |
| Protection degree                                       | IP20 (module), a separate housing is required acc. to the system description  |
| Mass  | approx. 750 g   |
| Dimensions  | 57 x 107 x 132 mm (2.2 x 4.2 x 5.2 in)  |
| <b>Data for application in connection with Ex-areas</b> |   |
| EC-Type Examination Certificate                         | PTB 97 ATEX 1074 U, PTB 97 ATEX 1075 (system)   |
| Group, category, type of protection                     | ⊕ II 2 (1) G Ex d [ia] IIC, [Ex iaD]  |
| Supply  | only in connection with the power supplies FB 92**  |
| <b>Directive conformity</b>                             |   |
| Directive 94/9/EC                                       | EN 60079-0, EN 60079-1, EN 60079-11, EN 60079-26, EN 61241-0, EN 61241-11   |
| <b>International approvals</b>                          |   |
| IECEX approval  | pending   |

**Features**

- 4-channel
- Inputs Ex ia
- Power supply for 2- or 3-wire transmitters with 4 mA ... 20 mA
- Supply circuit 15 V (20 mA)
- Input from active signals of 4-wire transmitters
- Installation in suitable enclosures in Zone 1 and Zone 21
- HART communication via field bus or service bus
- Module can be exchanged under voltage in Zone 1 (hot swap)
- Simulation mode for service operations (forcing)
- Line fault detection (LFD)
- Permanently self-monitoring
- EMC acc. to NAMUR NE 21

**Function**

The transmitter power supply feeds 2- and 3-wire transmitters. Active signals from separately powered field devices and 4-wire transmitters can be connected. Open and short circuit line fault alarms as well as Live Zero status are detected. The intrinsically safe inputs are galvanically isolated from the bus and the power supply (EN 60079-11).

**Diagrams**

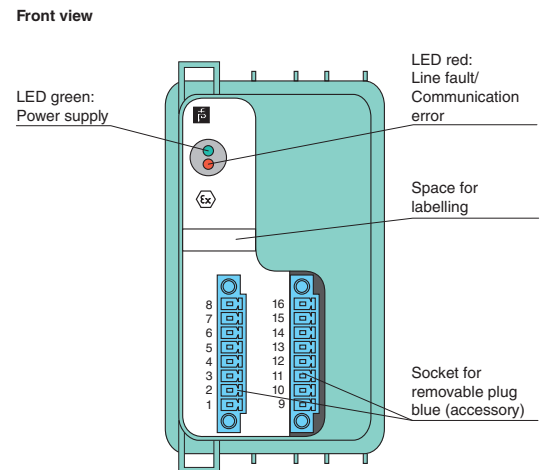
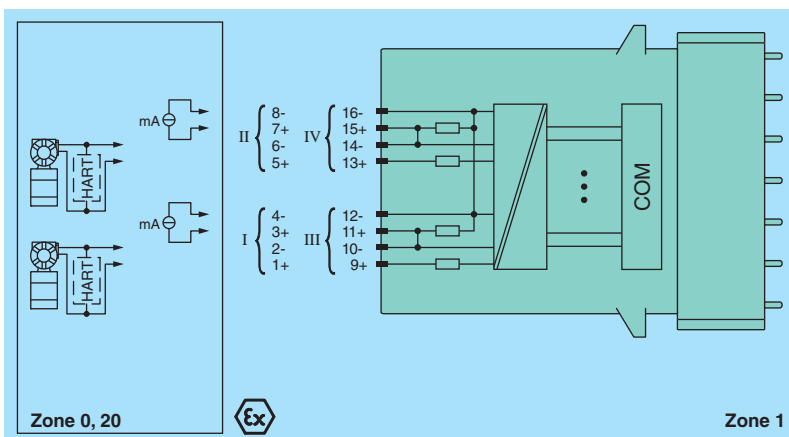

Edition 912907 (US) / 220718 (EU) 06/2011

Subject to modifications without notice

Pepperl+Fuchs Group  
www.pepperl-fuchs.com

USA: +1 330 486 0002  
pa-info@us.pepperl-fuchs.com

Germany: +49 621 776 2222  
pa-info@de.pepperl-fuchs.com

Copyright Pepperl+Fuchs  
Singapore: +65 6779 9091  
pa-info@sg.pepperl-fuchs.com



FB-System

Digital Inputs

Digital Outputs

Analog Inputs

Analog Outputs

Bus Couplers

Power Supplies

Accessories





FB-System

Digital Inputs

Digital Outputs

Analog Inputs

Analog Outputs

Bus Couplers

Power Supplies

Accessories

**Features**

- 1-channel
- Input wired to Ex e terminals
- Power supply for 2- or 3-wire transmitters with 4 mA ... 20 mA
- Supply circuit 16.5 V (20 mA)
- Input from active signals of 4-wire transmitters
- Installation in suitable enclosures in Zone 1 and Zone 21
- HART communication via field bus or service bus
- HART communication also for separately powered devices
- Module can be exchanged under voltage in Zone 1 (hot swap)
- Simulation mode for service operations (forcing)
- Line fault (LFD) and Live Zero detection
- Permanently self-monitoring
- EMC acc. to NAMUR NE 21

**Function**

The transmitter power supply feeds 2-and 3-wire transmitters. Active signals from separately powered field devices and 4-wire transmitters can be connected. Open and short circuit line fault alarms as well as Live Zero status are detected. The input is galvanically isolated from the bus and the power supply (EN 60079-11).

**Technical data**

|   |  |
|---|--|
| <b>Supply</b>   |  |
| Connection  | backplane bus  |
| Rated voltage   | 12 V DC, only in connection with the power supplies FB 92**  |
| Power consumption                                       | approx. 1.2 W  |
| <b>Internal bus</b>                                     |  |
| Connection  | backplane bus  |
| Interface   | manufacturer specific bus to standard Com Unit/gateway   |
| <b>Input</b>  |  |
| Suitable field devices                                  | pressure transmitters, differential pressure transmitters, level transmitters, flowmeters etc.         |
| Connection  | wire ends 2+ (brown), 5- (grey, HART supply), 1+ (white), 6- (pink, HART input)                        |
| Input resistance  | 15 Ω (terminals 5, 6)<br>236 Ω (terminals 1, 6), HART  |
| Transmitter supply voltage                              | min. 16 V at 20 mA<br>(incl. 250 Ω HART communication resistor)  |
| Lead monitoring   | Parameterization range 0 ... 26 mA<br>Ex works settings: line fault < 0.5 mA;<br>short circuit > 22 mA |
| Live Zero monitoring                                    | Ex works settings: ≤ 3.6 mA  |
| <b>Ambient conditions</b>                               |  |
| Ambient temperature                                     | -20 ... 60 °C (-4 ... 140 °F)  |
| Storage temperature                                     | -25 ... 85 °C (-13 ... 185 °F)   |
| <b>Mechanical specifications</b>                        |  |
| Protection degree                                       | IP20 (module), a separate housing is required acc. to the system description                           |
| Mass  | approx. 350 g  |
| Dimensions  | 28 x 107 x 132 mm (1.1 x 4.2 x 5.2 in)   |
| <b>Data for application in connection with Ex-areas</b> |  |
| EC-Type Examination Certificate                         | PTB 97 ATEX 1074 U, PTB 97 ATEX 1075 (system)  |
| Group, category, type of protection                     | ⊕ II 2 G Ex d II C   |
| Supply  | only in connection with the power supplies FB 92**   |
| <b>Directive conformity</b>                             |  |
| Directive 94/9/EC                                       | EN 60079-0, EN 60079-1   |
| <b>International approvals</b>                          |  |
| IECEx approval  | pending  |

**Diagrams**

Front view

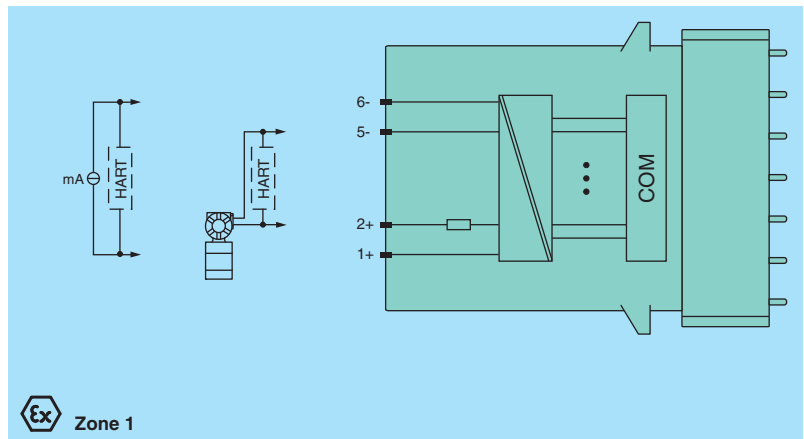
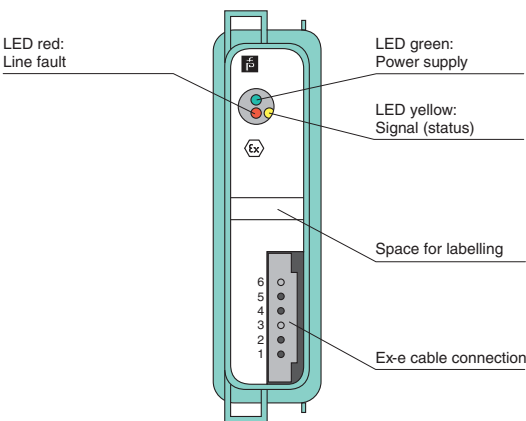

Edition 912907 (US) / 220718 (EU) 06/2011

| Technical data  |  |
|---|--|
| <b>Supply</b>   |  |
| Connection  | backplane bus  |
| Rated voltage   | 12 V DC, only in connection with the power supplies FB 92**  |
| Power consumption                                       | 3 W  |
| <b>Internal bus</b>                                     |  |
| Connection  | backplane bus  |
| Interface   | manufacturer specific bus to standard Com Unit/gateway   |
| <b>Input</b>  |  |
| Suitable field devices                                  | pressure transmitters, differential pressure transmitters, level transmitters, flowmeters etc.   |
| Connection  | wire ends 1+ (white), 2- (brown), 5+ (grey), 6- (pink), 9+ (white), 10- (brown), 13+ (grey), 14- (pink)<br>HART supply circuit<br>wire ends 3+, 4-/7+, 8-/11+, 12-/15+, 16- active field devices |
| Input resistance  | 15 Ω (stat.), no HART for separately powered field devices   |
| Transmitter supply voltage                              | min. 15 V at 20 mA   |
| Lead monitoring   | Parameterization range 0 ... 26 mA<br>Ex works settings: line fault < 0.5 mA;<br>short circuit > 22 mA   |
| Live Zero monitoring                                    | Ex works settings: ≤ 3.6 mA  |
| <b>Ambient conditions</b>                               |  |
| Ambient temperature                                     | -20 ... 60 °C (-4 ... 140 °F)  |
| Storage temperature                                     | -25 ... 85 °C (-13 ... 185 °F)   |
| <b>Mechanical specifications</b>                        |  |
| Protection degree                                       | IP20 (module), a separate housing is required acc. to the system description   |
| Mass  | approx. 750 g  |
| Dimensions  | 57 x 107 x 132 mm (2.2 x 4.2 x 5.2 in)   |
| <b>Data for application in connection with Ex-areas</b> | see page 231 for entity parameters   |
| EC-Type Examination Certificate                         | PTB 97 ATEX 1074 U, PTB 97 ATEX 1075 (system)  |
| Group, category, type of protection                     | ⊕ II 2 G Ex d II C   |
| Supply  | only in connection with the power supplies FB 92**   |
| <b>Directive conformity</b>                             |  |
| Directive 94/9/EC                                       | EN 60079-0, EN 60079-1   |
| <b>International approvals</b>                          |  |
| IECEx approval  | pending  |

**Features**

- 4-channel
- Inputs wired to Ex e terminals
- Power supply for 2- or 3-wire transmitters with 4 mA ... 20 mA
- Supply circuit 15 V (20 mA)
- Input from active signals of 4-wire transmitters
- Installation in suitable enclosures in Zone 1 and Zone 21
- HART communication via field bus or service bus
- Module can be exchanged under voltage in Zone 1 (hot swap)
- Simulation mode for service operations (forcing)
- Line fault detection (LFD)
- Permanently self-monitoring
- EMC acc. to NAMUR NE 21

**Function**

The transmitter power supply feeds 2- and 3-wire transmitters.

Active signals from separately powered field devices and 4-wire transmitters can be connected.

Open and short circuit line fault alarms as well as Live Zero status are detected.

The inputs are galvanically isolated from the bus and the power supply (EN 60079-11).

**Diagrams**

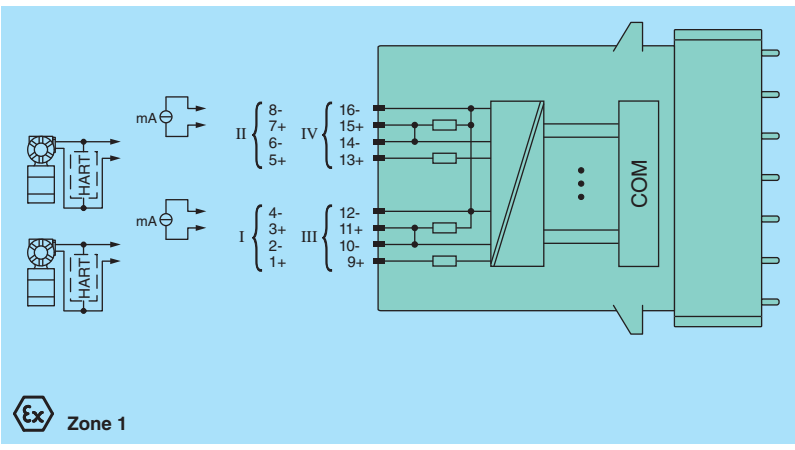

Front view

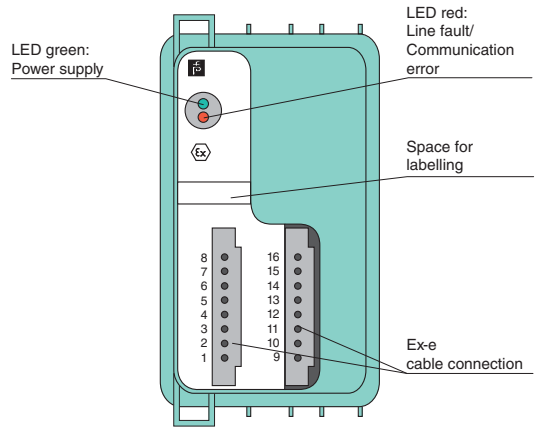

Edition 912907 (US) / 220718 (EU) 06/2011

Subject to modifications without notice

Pepperl+Fuchs Group  
www.pepperl-fuchs.com

USA: +1 330 486 0002  
pa-info@us.pepperl-fuchs.com

Germany: +49 621 776 2222  
pa-info@de.pepperl-fuchs.com

Copyright Pepperl+Fuchs  
Singapore: +65 6779 9091  
pa-info@sg.pepperl-fuchs.com

**PEPPERL+FUCHS 225**  
PROTECTING YOUR PROCESS

FB-System  
 Digital Inputs  
 Digital Outputs  
 Analog Inputs  
 Analog Outputs  
 Bus Couplers  
 Power Supplies  
 Accessories



FB-System

Digital Inputs

Digital Outputs

Analog Inputs

Analog Outputs

Bus Couplers

Power Supplies

Accessories

**Features**

- 1-channel
- Input Ex ia
- Converter for 2-, 3- and 4-wire Pt100, slide wire sensors
- Installation in suitable enclosures in Zone 1 and Zone 21
- Module can be exchanged under voltage in Zone 1 (hot swap)
- Simulation mode for service operations (forcing)
- Line fault detection (LFD)
- Permanently self-monitoring
- EMC acc. to NAMUR NE 21

**Function**

The temperature converter accepts 2, 3, 4-wire RTD (Pt100) signals from the hazardous area.

Open or short circuit line fault alarms are detected.

The intrinsically safe input is galvanically isolated from the bus and the power supply (EN 60079-11).

**Technical data**

**Supply**

|                   |   |
|-------------------|---|
| Connection        | backplane bus   |
| Rated voltage     | 12 V DC, only in connection with the power supplies FB 92** |
| Power consumption | 0.45 W  |

**Internal bus**

|            |  |
|------------|--|
| Connection | backplane bus  |
| Interface  | manufacturer specific bus to standard Com Unit/gateway |

**Input**

|                      |   |
|----------------------|---|
| Suitable sensors     | 2, 3, and 4 wire RTD (Pt100), 400 Ω slide-wire sensors  |
| Connection           | terminals 1, 2, 5, 6  |
| Line fault detection | option: On/Off, see connection diagram<br>switching point:<br>- short circuit: < 10 Ω<br>- open circuit: > 1 kΩ |

|                       |  |
|-----------------------|--|
| Lead resistance       | ≤ 50 Ω per strand                          |
| Measurement range     | 10 ... 400 Ω (500 Ω incl. line resistance) |
| Measuring current     | 200 μA                                     |
| Smallest span         | 20 Ω for 0.1 % accuracy                    |
| Linearity error       | 0.1 %                                      |
| Temperature influence | 0.1 %/10 K                                 |
| Conversion time       | ≤ 20 ms without LFD<br>≤ 150 ms with LFD   |

**Ambient conditions**

|                     |                                |
|---------------------|--------------------------------|
| Ambient temperature | -20 ... 60 °C (-4 ... 140 °F)  |
| Storage temperature | -25 ... 85 °C (-13 ... 185 °F) |

**Mechanical specifications**

|                   |  |
|-------------------|--|
| Protection degree | IP20 (module), a separate housing is required acc. to the system description |
| Mass              | approx. 350 g  |
| Dimensions        | 28 x 107 x 132 mm (1.1 x 4.2 x 5.2 in)                                       |

**Data for application in connection with Ex-areas**

|                                     |   |
|-------------------------------------|---|
| EC-Type Examination Certificate     | PTB 97 ATEX 1074 U, PTB 97 ATEX 1075 (system)                             |
| Group, category, type of protection | ⊕ II 2 (1) G Ex d [ia] IIC, [Ex iaD]                                      |
| Supply                              | only in connection with the power supplies FB 92**                        |
| Directive conformity                |   |
| Directive 94/9/EC                   | EN 60079-0, EN 60079-1, EN 60079-11, EN 60079-26, EN 61241-0, EN 61241-11 |

**International approvals**

|                |         |
|----------------|---------|
| IECEX approval | pending |
|----------------|---------|

**Diagrams**

Front view

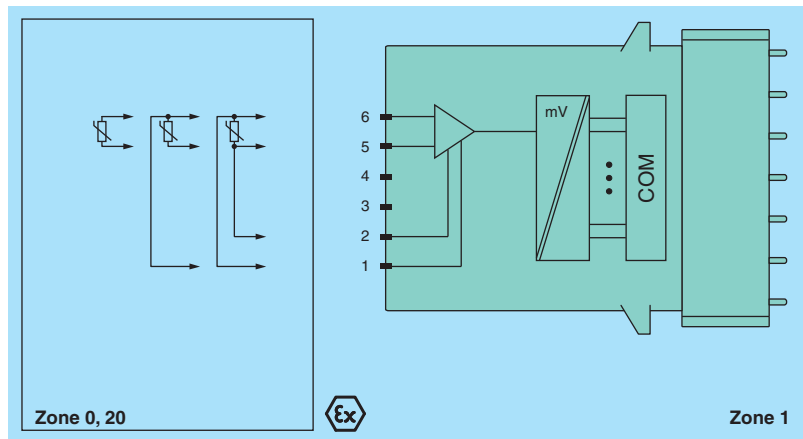
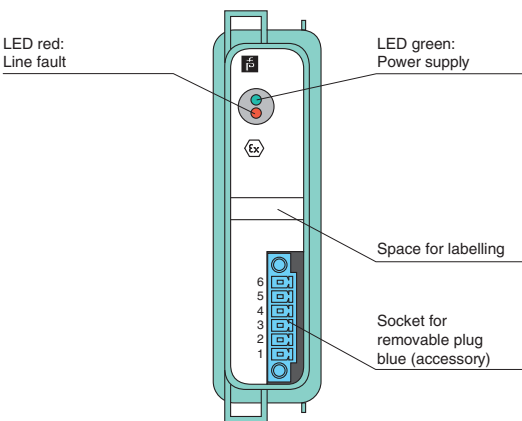

Edition 912907 (US) / 220718 (EU) 06/2011

| Technical data  |   |
|---|---|
| <b>Supply</b>   |   |
| Connection  | backplane bus   |
| Rated voltage   | 12 V DC, only in connection with the power supplies FB 92**                           |
| Power consumption                                       | 0.45 W  |
| <b>Internal bus</b>                                     |   |
| Connection  | backplane bus   |
| Interface   | manufacturer specific bus to standard Com Unit/gateway                                |
| <b>Input</b>  |   |
| Suitable sensors  | thermocouples U, B, E, T, K, S, R, L, J, N, Pallaplat and mV sources                  |
| Connection  | terminals 1, 2 (cold junction RTD), 5+, 6- (TC)                                       |
| Line fault detection                                    | option: On/Off, see connection diagram<br>switching points:<br>- open circuit: > 1 kΩ |
| Measurement range                                       | U, B, E, T, K, S, R, L, J, N, Pallaplat<br>-75 ... 75 mV                              |
| Linearity error   | 0.1 %   |
| Temperature influence                                   | 0.1 %/10 K  |
| Compensation (reference junction CJC)                   | internal or external (e. g. thermostat)   |
| Sensor current for Pt 100 CJC                           | 200 μA  |
| Line fault detection (LFD)                              | ≥ 1 kΩ  |
| <b>Ambient conditions</b>                               |   |
| Ambient temperature                                     | -20 ... 60 °C (-4 ... 140 °F)   |
| Storage temperature                                     | -25 ... 85 °C (-13 ... 185 °F)  |
| <b>Mechanical specifications</b>                        |   |
| Protection degree                                       | IP20 (module), a separate housing is required acc. to the system description          |
| Mass  | approx. 350 g   |
| Dimensions  | 28 x 107 x 132 mm (1.1 x 4.2 x 5.2 in)  |
| <b>Data for application in connection with Ex-areas</b> | see page 231 for entity parameters  |
| EC-Type Examination Certificate                         | PTB 97 ATEX 1074 U, PTB 97 ATEX 1075 (system)   |
| Group, category, type of protection                     | ⊕ II 2 (1) G Ex d [ia] IIC, [Ex iaD]  |
| Supply  | only in connection with the power supplies FB 92**                                    |
| Directive conformity                                    |   |
| Directive 94/9/EC                                       | EN 60079-0, EN 60079-1, EN 60079-11, EN 60079-26, EN 61241-0, EN 61241-11             |
| <b>International approvals</b>                          |   |
| IECEx approval  | pending   |

**Features**

- 1-channel
- Input Ex ia
- Converter for thermocouples and mV-signals
- Installation in suitable enclosures in Zone 1 and Zone 2
- Module can be exchanged under voltage in Zone 1 (hot swap)
- Simulation mode for service operations (forcing)
- Line fault detection (LFD)
- Permanently self-monitoring
- EMC acc. to NAMUR NE 21

**Function**

The mV input accepts thermocouple or mV signals from the hazardous area. Open circuit line fault alarms are detected. The intrinsically safe input is galvanically isolated from the bus and the power supply (EN 60079-11).

**Diagrams**

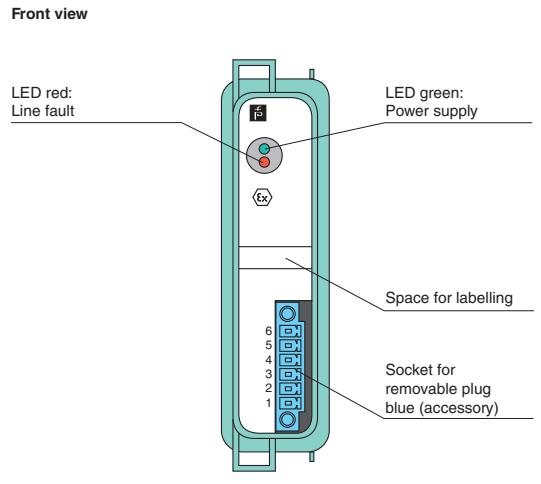
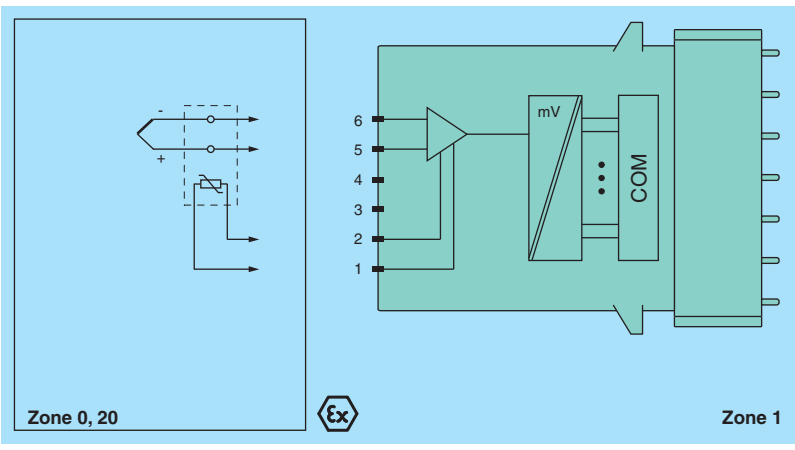

Edition 912907 (US) / 220718 (EU) 06/2011

FB-System  
Digital Inputs  
Digital Outputs  
Analog Inputs  
Analog Outputs  
Bus Couplers  
Power Supplies  
Accessories

Features

- 4-channel
- Inputs Ex ia
- Converter for 2-, 3- and 4-wire RTDs (Pt100 ... Pt1000), slide wire sensors etc.
- Installation in suitable enclosures in Zone 1 and Zone 21
- Module can be exchanged under voltage in Zone 1 (hot swap)
- Simulation mode for service operations (forcing)
- Line fault detection (LFD)
- Permanently self-monitoring
- EMC acc. to NAMUR NE 21

Function

The temperature converter accepts 2, 3, 4-wire RTD (Pt100 ... Pt1000) signals and slide wire sensors from the hazardous area. Ni100 through Ni1000 can also be connected.

Open or short circuit line fault alarms are detected.

The intrinsically safe inputs are galvanically isolated from the bus and the power supply ( EN 60079-11).

Technical data

Supply

|               |   |
|---------------|---|
| Connection    | backplane bus   |
| Rated voltage | 12 V DC, only in connection with the power supplies FB 92** |

|                   |       |
|-------------------|-------|
| Power consumption | 0.6 W |
|-------------------|-------|

Internal bus

|            |  |
|------------|--|
| Connection | backplane bus  |
| Interface  | manufacturer specific bus to standard Com Unit/gateway |

Input

|                                |   |
|--------------------------------|---|
| Suitable sensors               | 2, 3, and 4 wire RTD (Pt100), slide wire sensors etc.   |
| Connection                     | terminals 1-4, 5-8, 9-12, 13-16   |
| Lead resistance                | ≤ 50 Ω per strand   |
| Pt 100 range (-200 ... 850 °C) | 18 ... 390 Ω (500 Ω incl. line resistance)  |
| Measurement range              | Pt200 (37-780 Ω), Pt 500 (92-1952 Ω), Pt 1000 (185-3905 Ω), Ni100 (69-270 Ω), Ni500 (345-1350 Ω), Ni1000 (690-2700 Ω) |

|                               |   |
|-------------------------------|---|
| Slide-wire sensor             | 0 ... 10000 Ω                                 |
| Measuring current             | 200 µA  |
| Line fault detection (Pt 100) | ≥ 1 kΩ (open circuit), ≤ 10 Ω (short circuit) |
| Smallest span                 | 50 Ω (or 1/10 of the measuring range)         |
| Linearity error               | 0.1 %   |
| Temperature influence         | 0.1 %/10 K                                    |
| Busy after download           | 5 ... 15 s                                    |

Ambient conditions

|                     |                                |
|---------------------|--------------------------------|
| Ambient temperature | -20 ... 60 °C (-4 ... 140 °F)  |
| Storage temperature | -25 ... 85 °C (-13 ... 185 °F) |

Mechanical specifications

|                   |  |
|-------------------|--|
| Protection degree | IP20 (module), a separate housing is required acc. to the system description |
| Mass              | approx. 750 g  |
| Dimensions        | 57 x 107 x 132 mm (2.2 x 4.2 x 5.2 in)                                       |

Data for application in connection with Ex-areas

|                                     |   |
|-------------------------------------|---|
| EC-Type Examination Certificate     | PTB 97 ATEX 1074 U, PTB 97 ATEX 1075 (system)                             |
| Group, category, type of protection | Ex II 2 (1) G Ex d [ia] IIC, [Ex iaD]                                     |
| Supply                              | only in connection with the power supplies FB 92**                        |
| Directive conformity                |   |
| Directive 94/9/EC                   | EN 60079-0, EN 60079-1, EN 60079-11, EN 60079-26, EN 61241-0, EN 61241-11 |

International approvals

|                |         |
|----------------|---------|
| IECEX approval | pending |
|----------------|---------|

Diagrams

Front view

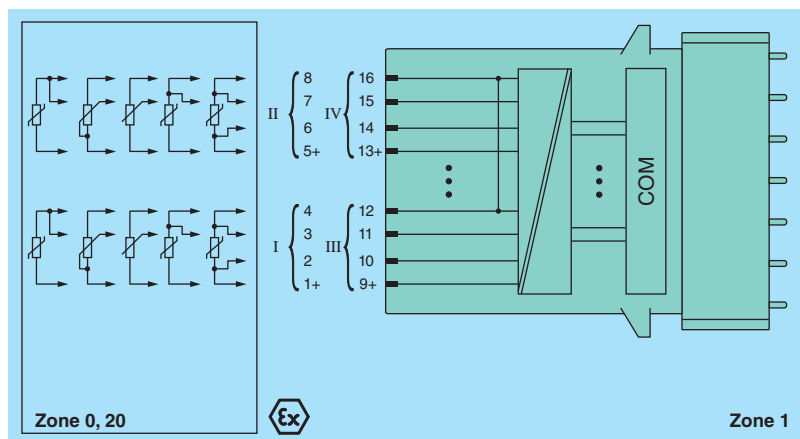
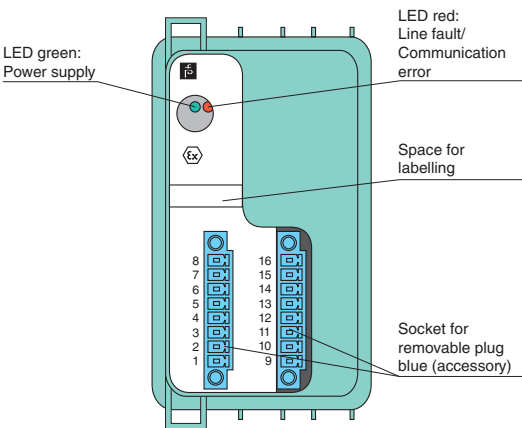

Edition 912907 (US) / 220718 (EU) 06/2011

| Technical data  |  |
|---|--|
| <b>Supply</b>   |  |
| Connection  | backplane bus  |
| Rated voltage   | 12 V DC, only in connection with the power supplies FB 92**                  |
| Power consumption                                       | 1 W  |
| <b>Internal bus</b>                                     |  |
| Connection  | backplane bus  |
| Interface   | manufacturer specific bus to standard Com Unit/gateway                       |
| <b>Input</b>  |  |
| Suitable sensors  | thermocouples U, B, E, T, K, S, R, L, J, N, Pallaplat and mV sources         |
| Connection  | terminals 1, 2, 5, 6, 9, 10, 13, 14  |
| Measurement range                                       | -65 ... 75 mV with LFD, -75 ... 75 mV without LFD                            |
| Smallest span   | 5 mV (for 0.1 %)   |
| Linearity error   | 0.1 %  |
| Temperature influence                                   | 0.1 %/10 K   |
| Conversion time   | ≤ 300 ms (4 channels) without LFD<br>≤ 600 ms (4-channel) with LFD           |
| Compensation (reference junction CJC)                   | internal (built-in) or external (e. g. thermostat)                           |
| Line fault detection (LFD)                              | ≥ 1 kΩ (open circuit)  |
| <b>Ambient conditions</b>                               |  |
| Ambient temperature                                     | -20 ... 60 °C (-4 ... 140 °F)  |
| Storage temperature                                     | -25 ... 85 °C (-13 ... 185 °F)   |
| <b>Mechanical specifications</b>                        |  |
| Protection degree                                       | IP20 (module), a separate housing is required acc. to the system description |
| Mass  | approx. 750 g  |
| Dimensions  | 57 x 107 x 132 mm (2.2 x 4.2 x 5.2 in)                                       |
| <b>Data for application in connection with Ex-areas</b> | see page 231 for entity parameters   |
| EC-Type Examination Certificate                         | PTB 97 ATEX 1074 U, PTB 97 ATEX 1075 (system)                                |
| Group, category, type of protection                     | ⊕ II 2 (1) G Ex d [ia] IIC, [Ex iaD]   |
| Supply  | only in connection with the power supplies FB 92**                           |
| Directive conformity                                    |  |
| Directive 94/9/EC                                       | EN 60079-0, EN 60079-1, EN 60079-11, EN 60079-26, EN 61241-0, EN 61241-11    |
| <b>International approvals</b>                          |  |
| IECEX approval  | pending  |

Features

- 4-channel
- Inputs Ex ia
- Converter for thermocouples and mV-signals
- Installation in suitable enclosures in Zone 1 and Zone 21
- Module can be exchanged under voltage in Zone 1 (hot swap)
- Simulation mode for service operations (forcing)
- Line fault detection (LFD)
- Permanently self-monitoring
- EMC acc. to NAMUR NE 21

Function

The thermocouple converter accepts thermocouple or mV signals from the field.

Open circuit line fault alarms are detected.

The inputs are galvanically isolated from the bus and the power supply (EN 60079-11). There is a functional isolation between the channels.

Diagrams

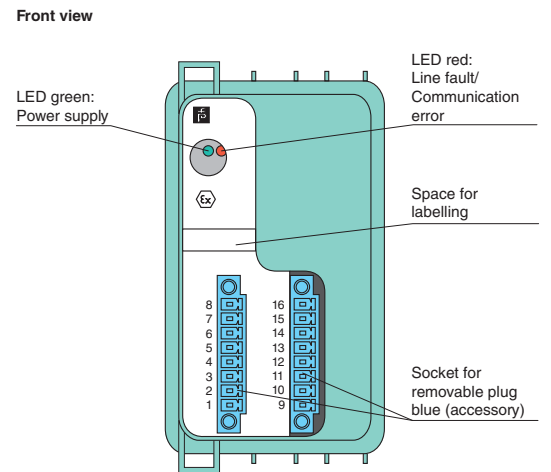
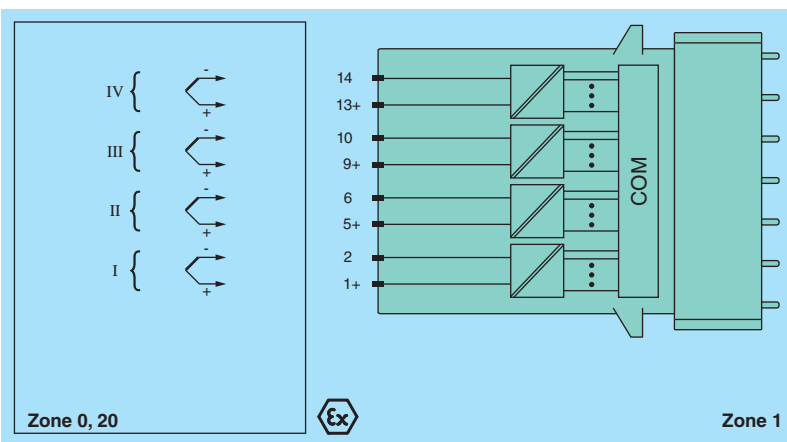

Edition 912907 (US) / 220718 (EU) 06/2011

Subject to modifications without notice

Pepperl+Fuchs Group  
www.pepperl-fuchs.com

USA: +1 330 486 0002  
pa-info@us.pepperl-fuchs.com

Germany: +49 621 776 2222  
pa-info@de.pepperl-fuchs.com

Copyright Pepperl+Fuchs  
Singapore: +65 6779 9091  
pa-info@sg.pepperl-fuchs.com

**PEPPERL+FUCHS 229**  
PROTECTING YOUR PROCESS



FB-System

Digital Inputs

Digital Outputs

Analog Inputs

Analog Outputs

Bus Couplers

Power Supplies

Accessories



FB-System

Digital Inputs

Digital Outputs

Analog Inputs

Analog Outputs

Bus Couplers

Power Supplies

Accessories

**Features**

- 1-channel
- Input Ex ia
- Input 0 V ... 10 V
- Installation in suitable enclosures in Zone 1 and Zone 21
- Module can be exchanged under voltage in Zone 1 (hot swap)
- Simulation mode for service operations (forcing)
- Permanently self-monitoring
- EMC acc. to NAMUR NE 21

**Function**

The voltage converter accepts signals from the hazardous area.  
The input is galvanically isolated from the bus and the power supply (EN 60079-11).

**Technical data**

|   |  |
|---|--|
| <b>Supply</b>   |  |
| Connection  | backplane bus  |
| Rated voltage   | 12 V DC, only in connection with the power supplies FB 92**                  |
| Power consumption                                       | 0.45 W   |
| <b>Internal bus</b>                                     |  |
| Connection  | backplane bus  |
| Interface   | manufacturer specific bus to standard Com Unit/gateway                       |
| <b>Input</b>  |  |
| Connection  | terminals 5+, 6-   |
| Input resistance  | 100 kΩ   |
| Measurement range                                       | 0 ... 10 V   |
| Smallest span   | 500 mV   |
| Linearity error   | 0.1 %  |
| Temperature influence                                   | 0.1 %/10 K   |
| Conversion time   | ≤ 100 ms   |
| <b>Ambient conditions</b>                               |  |
| Ambient temperature                                     | -20 ... 60 °C (-4 ... 140 °F)  |
| Storage temperature                                     | -25 ... 85 °C (-13 ... 185 °F)   |
| <b>Mechanical specifications</b>                        |  |
| Protection degree                                       | IP20 (module), a separate housing is required acc. to the system description |
| Mass  | approx. 350 g  |
| Dimensions  | 28 x 107 x 132 mm (1.1 x 4.2 x 5.2 in)                                       |
| <b>Data for application in connection with Ex-areas</b> | see page 231 for entity parameters   |
| EC-Type Examination Certificate                         | PTB 97 ATEX 1074 U, PTB 97 ATEX 1075 (system)                                |
| Group, category, type of protection                     | ⊕ II 2 (1) G Ex d [ia] IIC, [Ex iaD]   |
| Supply  | only in connection with the power supplies FB 92**                           |
| Directive conformity                                    |  |
| Directive 94/9/EC                                       | EN 60079-0, EN 60079-1, EN 60079-11, EN 60079-26, EN 61241-0, EN 61241-11    |
| <b>International approvals</b>                          |  |
| IECEx approval  | pending  |

**Diagrams**

Front view

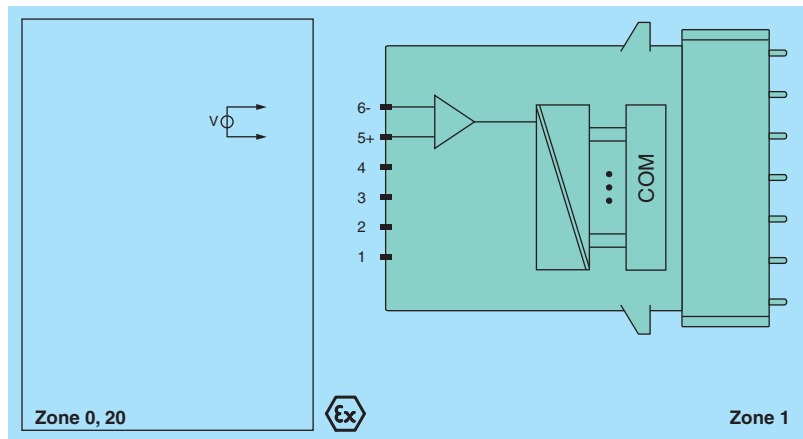
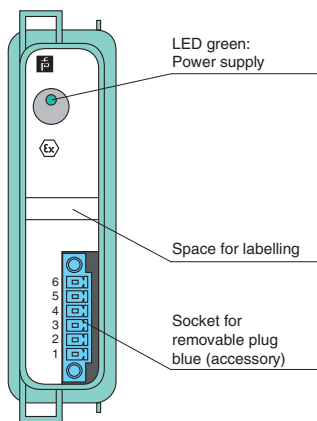

Edition 912907 (US) / 220718 (EU) 06/2011

## ATEX Entity Parameters

| Model Number | Terminals  | $U_o$ (V)  | $I_o$ (mA) | $P_o$ (mW) | $P_D$ (W) |
|--------------|--|------------|------------|------------|-----------|
| FB 3202 B    | 4/5+, 6<br>1+, 6-  | 0.7<br>8.9 | 3<br>56    | 2<br>336   | 1.2       |
| FB 3205 B    | 3+, 4-; 7+, 8-; 11+, 12-; 15+, 16-                       | 0.7        | 2.3        | 2          | 2.4       |
| FB 3302 **   | 4/5+, 6<br>1+, 6-  | –          | –          | –          | 1.2       |
| FB 3305 **   | 3+, 4-; 7+, 8-; 11+, 12-; 15+, 16-                       | –          | –          | –          | 2.4       |
| FB 5201 B    | 5, 6; 5, 1, 6; 1, 2, 5, 6                                | 2.7        | 43         | 93         | 0.5       |
| FB 5202 B    | 1+, 2-, 5+, 6-   | 1.8        | 43         | 67         | 0.5       |
| FB 5204 B    | 1, 2, 3, 4; 5, 6, 7, 8;<br>9, 10, 11, 12; 13, 14, 15, 16 | 7.14       | 70         | 123        | 0.6       |
| FB 5205 B    | 1+, 2-; 5+, 6-; 9+, 10-; 13+, 14-                        | 1.0        | 71         | 62         | 1         |
| FB 5206 B    | 5+, 6-   | 0.9        | 0.2        | 0.2        | 0.5       |



FB-System

Digital  
InputsDigital  
OutputsAnalog  
InputsAnalog  
OutputsBus  
CouplersPower  
Supplies

Accessories





## Analog Outputs

| Model Number             | Channels | Occupied Slots | Output (Field)   |                   |                            |                 |                    | SIL | Output Ex ia | Output Ex e | Mounting in Suitable Enclosures in Zone 1 and Zone 21 | Page |
|--------------------------|----------|----------------|------------------|-------------------|----------------------------|-----------------|--------------------|-----|--------------|-------------|---|------|
|                          |          |                | 0/4 mA ... 20 mA | Watchdog Function | Line Fault Detection (LFD) | Simulation Mode | HART Communication |     |              |             |   |      |
| FB 4202 B <sup>1</sup>   | 1        | 1              | ■                | ■                 | ■                          | ■               | ■                  |     | ■            |             | ■   | 234  |
| FB 4202 C                | 1        | 1              | ■                | ■                 | ■                          | ■               | ■                  | 2   | ■            |             | ■   | 235  |
| FB 4205 C                | 4        | 2              | ■                | ■                 |                            | ■               | ■                  | 2   | ■            |             | ■   | 236  |
| FB 4205 D <sup>2,3</sup> | 4        | 2              | ■                | ■                 | ■                          | ■               | ■                  |     | ■            |             | ■   | 237  |
| FB 4302 B                | 1        | 1              | ■                | ■                 | ■                          | ■               | ■                  |     |              | ■           | ■   | 238  |
| FB 4302 C                | 1        | 1              | ■                | ■                 | ■                          | ■               | ■                  | 2   |              | ■           | ■   | 239  |
| FB 4305 C                | 4        | 2              | ■                | ■                 |                            | ■               | ■                  | 2   |              | ■           | ■   | 240  |
| FB 4305 D                | 4        | 2              | ■                | ■                 | ■                          | ■               | ■                  |     |              | ■           | ■   | 241  |

<sup>1</sup> FB 4202 B compatible replacement for FB 4201 B (spares available) – same IS parameters, added HART function <sup>4</sup>

<sup>2</sup> FB 4205 D compatible replacement for FB 4204 B (spares available) – same IS parameters, added HART function <sup>4</sup>

<sup>3</sup> FB 4205 D compatible replacement for FB 4205 B (spares available) – new gateways allow LFD to be switched off

<sup>4</sup> Replacements require configuration changes in existing installations. This can be done in a running system as it does not affect communications with the master (HCiR).



FB-System

Digital Inputs

Digital Outputs

Analog Inputs

Analog Outputs

Bus Couplers

Power Supplies

Accessories



FB-System

Digital Inputs

Digital Outputs

Analog Inputs

Analog Outputs

Bus Couplers

Power Supplies

Accessories

**Features**

- 1-channel
- Output Ex ia
- Analog output module for 0/4 mA ... 20 mA
- Device installation in suitable enclosures in Zone 1 and Zone 21
- HART communication via field bus or service bus
- Module can be exchanged under voltage in Zone 1 (hot swap)
- Simulation mode for service operations (forcing)
- Line fault detection (LFD)
- Permanently self-monitoring
- EMC acc. to NAMUR NE 21

**Function**

The analog output drives positioners, proportional valves, I/P converters, or local indicators.

Open circuit line fault alarms are detected, depending on the parameter setting.

The output is galvanically isolated from the bus and the power supply (EN 60079-11).

**Technical data**

**Supply**

|                   |   |
|-------------------|---|
| Connection        | backplane bus   |
| Rated voltage     | 12 V DC, only in connection with the power supplies FB 92** |
| Power consumption | 0.73 W  |

**Internal bus**

|            |  |
|------------|--|
| Connection | backplane bus  |
| Interface  | manufacturer specific bus to standard Com Unit/gateway |

**Output**

|                      |  |
|----------------------|--|
| Connection           | terminals 2+, 3+/4-, 5-                              |
| Current              | 4 ... 20 mA (0 ... 25 mA)<br>short circuit protected |
| Load                 | 750 Ω max.   |
| Line fault detection | min. 1 mA  |
| Response threshold   | ≥ 850 Ω  |
| Watchdog             | output Off 0.5 s after serious fault                 |

**Ambient conditions**

|                     |                                |
|---------------------|--------------------------------|
| Ambient temperature | -20 ... 60 °C (-4 ... 140 °F)  |
| Storage temperature | -25 ... 85 °C (-13 ... 185 °F) |

**Mechanical specifications**

|                   |   |
|-------------------|---|
| Protection degree | IP20 (module), a separate housing is required acc. to the system description  |
| Connection        | device plug (accessories)<br>- removable terminals<br>- plug with screw flange<br>- wiring connection: spring terminals: (0.14 ... 1.5 mm <sup>2</sup> ),<br>screw terminals: (0.08 ... 1.5 mm <sup>2</sup> ) |

|            |  |
|------------|--|
| Mass       | approx. 350 g                          |
| Dimensions | 28 x 107 x 132 mm (1.1 x 4.2 x 5.2 in) |

**Data for application in connection with Ex-areas**

|                                     |   |
|-------------------------------------|---|
| EC-Type Examination Certificate     | PTB 97 ATEX 1074 U, PTB 97 ATEX 1075 (system)                             |
| Group, category, type of protection | ⊕ II 2 (1) G Ex d [ia] IIC, [Ex iaD]                                      |
| Supply                              | only in connection with the power supplies FB 92**                        |
| Directive conformity                |   |
| Directive 94/9/EC                   | EN 60079-0, EN 60079-1, EN 60079-11, EN 60079-26, EN 61241-0, EN 61241-11 |

**International approvals**

|                |         |
|----------------|---------|
| IECEx approval | pending |
|----------------|---------|

**Diagrams**

Front view

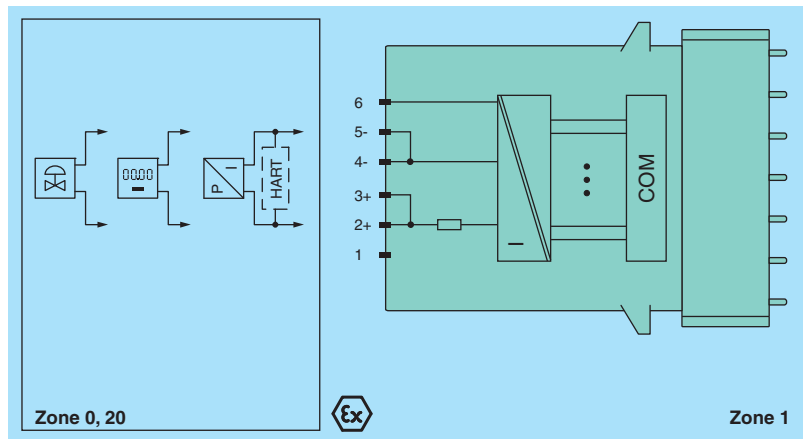
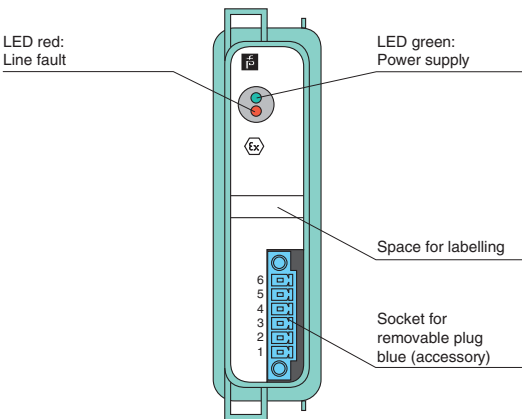

Edition 912907 (US) / 220718 (EU) 06/2011

| Technical data  |  |
|---|--|
| <b>Supply</b>   |  |
| Connection  | backplane bus  |
| Rated voltage   | 12 V DC, only in connection with the power supplies FB 92**  |
| Power consumption                                       | 0.73 W   |
| <b>Internal bus</b>                                     |  |
| Connection  | backplane bus  |
| Interface   | manufacturer specific bus to standard Com Unit/gateway   |
| <b>Output</b>   |  |
| Connection  | terminals 2+, 3+/4-, 5-  |
| Current   | 4 ... 20 mA (0 ... 25 mA)<br>short circuit protected   |
| Load  | 750 Ω max.   |
| Line fault detection                                    | min. 1 mA  |
| Response threshold                                      | ≥ 850 Ω  |
| Watchdog  | output Off 0.5 s after serious fault   |
| <b>Ambient conditions</b>                               |  |
| Ambient temperature                                     | -20 ... 60 °C (-4 ... 140 °F)  |
| Storage temperature                                     | -25 ... 85 °C (-13 ... 185 °F)   |
| <b>Mechanical specifications</b>                        |  |
| Protection degree                                       | IP20 (module), a separate housing is required acc. to the system description   |
| Connection  | device plug (accessories)<br>- removable terminals<br>- plug with screw flange<br>- wiring connection: spring terminals: (0.14 ... 1.5 mm <sup>2</sup> ), screw terminals: (0.08 ... 1.5 mm <sup>2</sup> ) |
| Mass  | approx. 350 g  |
| Dimensions  | 28 x 107 x 132 mm (1.1 x 4.2 x 5.2 in)   |
| <b>Data for application in connection with Ex-areas</b> | see page 242 for entity parameters   |
| EC-Type Examination Certificate                         | PTB 97 ATEX 1074 U, PTB 97 ATEX 1075 (system)  |
| Group, category, type of protection                     | ⊕ II 2 (1) G Ex d [ia] IIC, [Ex iaD]   |
| Supply  | only in connection with the power supplies FB 92**   |
| Directive conformity                                    |  |
| Directive 94/9/EC                                       | EN 60079-0, EN 60079-1, EN 60079-11, EN 60079-26, EN 61241-0, EN 61241-11  |
| <b>International approvals</b>                          |  |
| IECEx approval  | pending  |

**Features**

- 1-channel
- Output Ex ia
- Device installation in suitable enclosures in Zone 1 and Zone 21
- Analog output module for 0/4 mA ... 20 mA
- HART communication via field bus or service bus
- HART communication also for separately powered devices
- Module can be exchanged under voltage in Zone 1 (hot swap)
- Simulation mode for service operations (forcing)
- Line fault detection (LFD)
- Permanently self-monitoring
- EMC acc. to NAMUR NE 21
- Up to SIL2 acc. to IEC 61508

**Function**

The analog output drives positioners, proportional valves, I/P converters, or local indicators.

Open circuit line fault alarms are detected.

The output can be switched off via a contact. This can be used for bus-independent safety applications.

The output is galvanically isolated from the bus and the power supply (EN 60079-11).

**Diagrams**

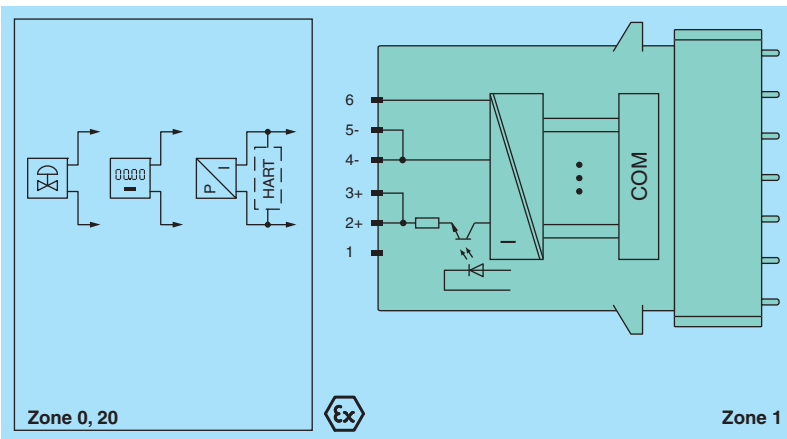

Front view

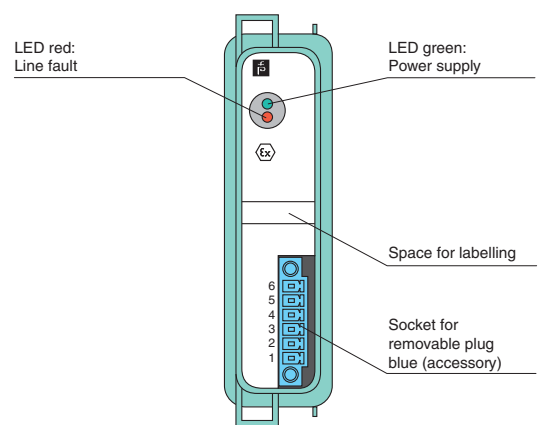

Edition 912907 (US) / 220718 (EU) 06/2011

Subject to modifications without notice

Pepperl+Fuchs Group  
www.pepperl-fuchs.com

USA: +1 330 486 0002  
pa-info@us.pepperl-fuchs.com

Germany: +49 621 776 2222  
pa-info@de.pepperl-fuchs.com

Copyright Pepperl+Fuchs  
Singapore: +65 6779 9091  
pa-info@sg.pepperl-fuchs.com



FB-System

Digital Inputs

Digital Outputs

Analog Inputs

Analog Outputs

Bus Couplers

Power Supplies

Accessories





FB-System

Digital Inputs

Digital Outputs

Analog Inputs

Analog Outputs

Bus Couplers

Power Supplies

Accessories



**Features**

- 4-channel
- Outputs Ex ia
- Device installation in suitable enclosures in Zone 1 and Zone 2 I
- Analog output module for 0/4 mA ... 20 mA
- HART communication via field bus or service bus
- Module can be exchanged under voltage in Zone 1 (hot swap)
- Simulation mode for service operations (forcing)
- Line fault detection (LFD)
- Permanently self-monitoring
- EMC acc. to NAMUR NE 21
- Up to SIL2 acc. to IEC 61508

**Function**

The analog output drives positioners, proportional valves, I/P converters, or local indicators.

Open circuit line fault alarms are detected.

The output can be switched off via a contact. This can be used for bus-independent safety applications.

The output is galvanically isolated from the bus and the power supply (EN 60079-11).

**Technical data**

|   |  |
|---|--|
| <b>Supply</b>   |  |
| Connection  | backplane bus  |
| Rated voltage   | 12 V DC, only in connection with the power supplies FB 92**  |
| Power consumption                                       | 3 W  |
| <b>Internal bus</b>                                     |  |
| Connection  | backplane bus  |
| Interface   | manufacturer specific bus to standard Com Unit/gateway   |
| <b>Output</b>   |  |
| Connection  | terminals 1+, 2-, 3+, 4-, 5+, 6-, 7+, 8-   |
| Current   | 4 ... 20 mA (0 ... 25 mA)<br>short circuit protected   |
| Load  | 750 Ω max.   |
| Line fault detection                                    | min. 1 mA  |
| Response threshold                                      | ≥ 850 Ω  |
| Watchdog  | output Off 0.5 s after serious fault   |
| <b>Ambient conditions</b>                               |  |
| Ambient temperature                                     | -20 ... 60 °C (-4 ... 140 °F)  |
| Storage temperature                                     | -25 ... 85 °C (-13 ... 185 °F)   |
| <b>Mechanical specifications</b>                        |  |
| Protection degree                                       | IP20 (module), a separate housing is required acc. to the system description   |
| Connection  | device plug (accessories)<br>- removable terminals<br>- plug with screw flange<br>- wiring connection: spring terminals: (0.14 ... 1.5 mm <sup>2</sup> ), screw terminals: (0.08 ... 1.5 mm <sup>2</sup> ) |
| Mass  | approx. 750 g  |
| Dimensions  | 57 x 107 x 132 mm (2.2 x 4.2 x 5.2 in)   |
| <b>Data for application in connection with Ex-areas</b> |  |
| EC-Type Examination Certificate                         | PTB 97 ATEX 1074 U, PTB 97 ATEX 1075 (system)  |
| Group, category, type of protection                     | ⊕ II 2 (1) G Ex d [ia] IIC, [Ex iaD]   |
| Supply  | only in connection with the power supplies FB 92**   |
| Directive conformity                                    |  |
| Directive 94/9/EC                                       | EN 60079-0, EN 60079-1, EN 60079-11, EN 60079-26, EN 61241-0, EN 61241-11  |
| <b>International approvals</b>                          |  |
| IECEx approval  | pending  |

**Diagrams**

Front view

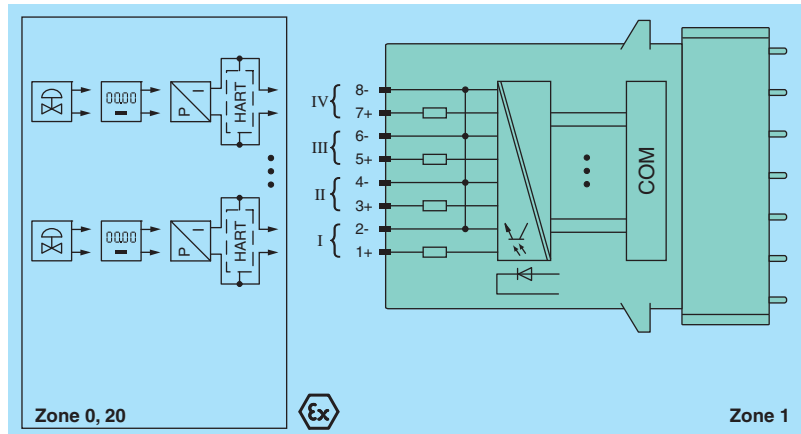
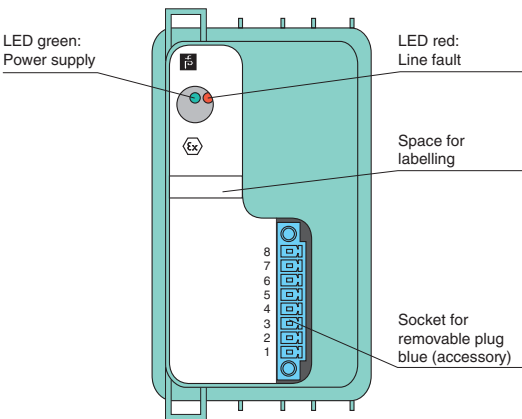

Edition 912907 (US) / 220718 (EU) 06/2011

| Technical data  |  |
|---|--|
| <b>Supply</b>   |  |
| Connection  | backplane bus  |
| Rated voltage   | 12 V DC, only in connection with the power supplies FB **  |
| Power consumption                                       | 3 W  |
| <b>Internal bus</b>                                     |  |
| Connection  | backplane bus  |
| Interface   | manufacturer specific bus to standard Com Unit/gateway   |
| <b>Output</b>   |  |
| Connection  | terminals 1+, 2-, 3+, 4-, 5+, 6-, 7+, 8-   |
| Current   | 4 ... 20 mA (0 ... 25 mA)<br>short circuit protected   |
| Load  | 750 Ω max.   |
| Line fault detection                                    | min. 1 mA  |
| Response threshold                                      | ≥ 850 Ω  |
| Watchdog  | output Off 0.5 s after serious fault   |
| <b>Ambient conditions</b>                               |  |
| Ambient temperature                                     | -20 ... 60 °C (-4 ... 140 °F)  |
| Storage temperature                                     | -25 ... 85 °C (-13 ... 185 °F)   |
| <b>Mechanical specifications</b>                        |  |
| Protection degree                                       | IP20 (module), a separate housing is required acc. to the system description   |
| Connection  | device plug (accessories)<br>- removable terminals<br>- plug with screw flange<br>- wiring connection: spring terminals: (0.14 ... 1.5 mm <sup>2</sup> ), screw terminals: (0.08 ... 1.5 mm <sup>2</sup> ) |
| Mass  | approx. 750 g  |
| Dimensions  | 57 x 107 x 132 mm (2.2 x 4.2 x 5.2 in)   |
| <b>Data for application in connection with Ex-areas</b> | see page 242 for entity parameters   |
| EC-Type Examination Certificate                         | PTB 97 ATEX 1074 U, PTB 97 ATEX 1075 (system)  |
| Group, category, type of protection                     | ⊕ II 2 (1) G Ex d [ia] IIC, [Ex iaD]   |
| Supply  | only in connection with the power supplies FB 92**   |
| Directive conformity                                    |  |
| Directive 94/9/EC                                       | EN 60079-0, EN 60079-1, EN 60079-11, EN 60079-26, EN 61241-0, EN 61241-11  |
| <b>International approvals</b>                          |  |
| IECEx approval  | pending  |

**Features**

- 4-channel
- Outputs Ex ia
- Device installation in suitable enclosures in Zone 1 and Zone 21
- Analog output module for 0/4 mA ... 20 mA
- HART communication via field bus or service bus
- Module can be exchanged under voltage in Zone 1 (hot swap)
- Simulation mode for service operations (forcing)
- Line fault detection (LFD)
- Permanently self-monitoring
- EMC acc. to NAMUR NE 21

**Function**

The analog output drives positioners, proportional valves, I/P converters, or local indicators.  
Open circuit line faults are detected.  
The outputs are galvanically isolated from the bus and the power supply (EN 60079-11).

**Diagrams**

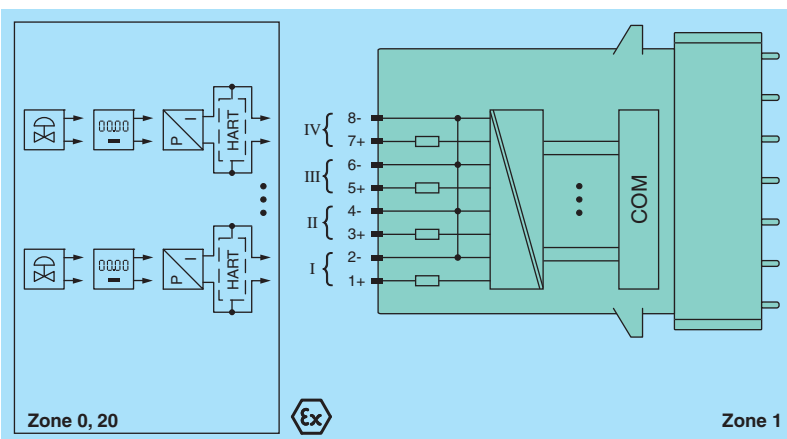

Front view

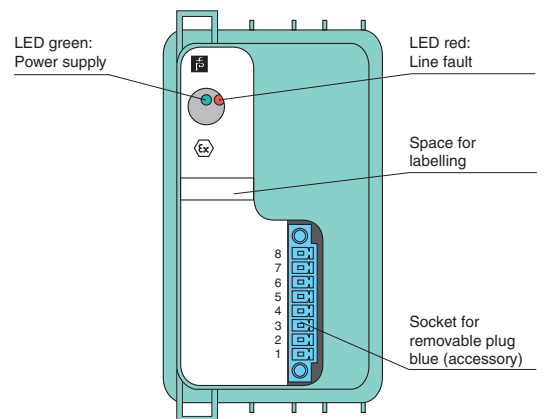

Edition 912907 (US) / 220718 (EU) 06/2011

Subject to modifications without notice

Pepperl+Fuchs Group  
www.pepperl-fuchs.com

USA: +1 330 486 0002  
pa-info@us.pepperl-fuchs.com

Germany: +49 621 776 2222  
pa-info@de.pepperl-fuchs.com

Copyright Pepperl+Fuchs  
Singapore: +65 6779 9091  
pa-info@sg.pepperl-fuchs.com



FB-System

Digital Inputs

Digital Outputs

Analog Inputs

Analog Outputs

Bus Couplers

Power Supplies

Accessories



FB-System

Digital Inputs

Digital Outputs

Analog Inputs

Analog Outputs

Bus Couplers

Power Supplies

Accessories

**Features**

- 1-channel
- Output wired to Ex e terminals
- Device installation in suitable enclosures in Zone 1 and Zone 21
- Analog output module for 0/4 mA ... 20 mA
- HART communication via field bus or service bus
- Module can be exchanged under voltage in Zone 1 (hot swap)
- Simulation mode for service operations (forcing)
- Line fault detection (LFD)
- Output with watchdog circuit
- Permanently self-monitoring
- EMC acc. to NAMUR NE 21

**Function**

The analog output drives positioners, proportional valves, I/P converters, or local indicators.

Open circuit line fault alarms are detected, depending on the parameter setting.

The output is galvanically isolated from the bus and the power supply (EN 60079-11).

**Technical data**

**Supply**

|               |   |
|---------------|---|
| Connection    | backplane bus   |
| Rated voltage | 12 V DC, only in connection with the power supplies FB 92** |

|                   |        |
|-------------------|--------|
| Power consumption | 0.73 W |
|-------------------|--------|

**Internal bus**

|            |  |
|------------|--|
| Connection | backplane bus  |
| Interface  | manufacturer specific bus to standard Com Unit/gateway |

**Output**

|            |  |
|------------|--|
| Connection | wire ends 2+ (brown), 3+ (green), 4- (yellow), 5- (grey) |
| Current    | 4 ... 20 mA (0 ... 25 mA)<br>short circuit protected     |

|      |            |
|------|------------|
| Load | 750 Ω max. |
|------|------------|

|                      |           |
|----------------------|-----------|
| Line fault detection | min. 1 mA |
|----------------------|-----------|

|                    |         |
|--------------------|---------|
| Response threshold | ≥ 850 Ω |
|--------------------|---------|

|          |                                      |
|----------|--------------------------------------|
| Watchdog | output Off 0.5 s after serious fault |
|----------|--------------------------------------|

**Ambient conditions**

|                     |                               |
|---------------------|-------------------------------|
| Ambient temperature | -20 ... 60 °C (-4 ... 140 °F) |
|---------------------|-------------------------------|

|                     |                                |
|---------------------|--------------------------------|
| Storage temperature | -25 ... 85 °C (-13 ... 185 °F) |
|---------------------|--------------------------------|

**Mechanical specifications**

|                   |  |
|-------------------|--|
| Protection degree | IP20 (module), a separate housing is required acc. to the system description |
|-------------------|--|

|            |  |
|------------|--|
| Connection | wire ends/cable tails<br>wiring connection<br>separately covered Ex-e terminals required |
|------------|--|

|      |               |
|------|---------------|
| Mass | approx. 350 g |
|------|---------------|

|            |  |
|------------|--|
| Dimensions | 28 x 107 x 132 mm (1.1 x 4.2 x 5.2 in) |
|------------|--|

**Data for application in connection with Ex-areas** see page 242 for entity parameters

|                                 |   |
|---------------------------------|---|
| EC-Type Examination Certificate | PTB 97 ATEX 1074 U, PTB 97 ATEX 1075 (system) |
|---------------------------------|---|

|                                     |                    |
|-------------------------------------|--------------------|
| Group, category, type of protection | ⊕ II 2 G Ex d II C |
|-------------------------------------|--------------------|

|        |  |
|--------|--|
| Supply | only in connection with the power supplies FB 92** |
|--------|--|

Directive conformity

|                   |                        |
|-------------------|------------------------|
| Directive 94/9/EC | EN 60079-0, EN 60079-1 |
|-------------------|------------------------|

**International approvals**

|                |         |
|----------------|---------|
| IECEx approval | pending |
|----------------|---------|

**Diagrams**

Front view

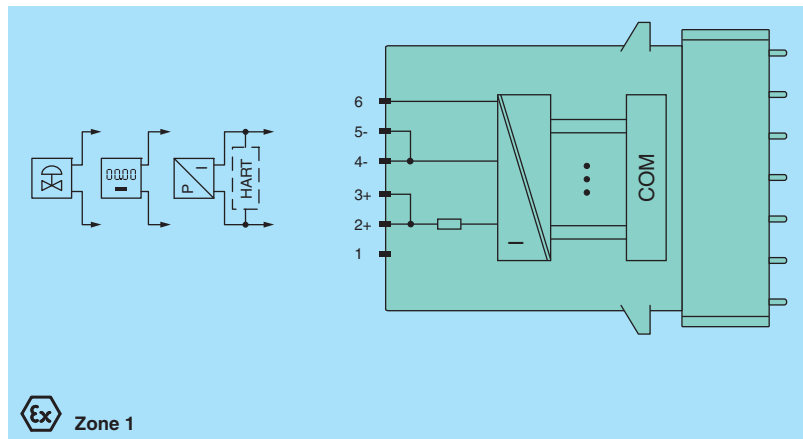
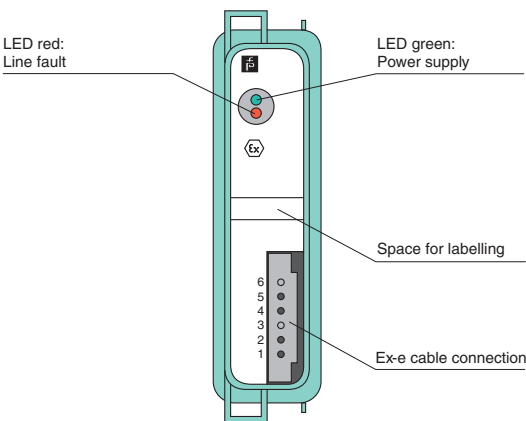

Edition 912907 (US) / 220718 (EU) 06/2011

| Technical data  |  |
|---|--|
| <b>Supply</b>   |  |
| Connection  | backplane bus  |
| Rated voltage   | 12 V DC, only in connection with the power supplies FB 92**                              |
| Power consumption                                       | 0.73 W   |
| <b>Internal bus</b>                                     |  |
| Connection  | backplane bus  |
| Interface   | manufacturer specific bus to standard Com Unit/gateway                                   |
| <b>Output</b>   |  |
| Connection  | wire ends 2+ (brown), 3+ (green), 4- (yellow), 5- (grey)                                 |
| Current   | 4 ... 20 mA (0 ... 25 mA)<br>short circuit protected                                     |
| Load  | 750 Ω max.   |
| Line fault detection                                    | min. 1 mA  |
| Response threshold                                      | ≥ 850 Ω  |
| Watchdog  | output Off 0.5 s after serious fault   |
| <b>Ambient conditions</b>                               |  |
| Ambient temperature                                     | -20 ... 60 °C (-4 ... 140 °F)  |
| Storage temperature                                     | -25 ... 85 °C (-13 ... 185 °F)   |
| <b>Mechanical specifications</b>                        |  |
| Protection degree                                       | IP20 (module), a separate housing is required acc. to the system description             |
| Connection  | wire ends/cable tails<br>wiring connection<br>separately covered Ex-e terminals required |
| Mass  | approx. 350 g  |
| Dimensions  | 28 x 107 x 132 mm (1.1 x 4.2 x 5.2 in)   |
| <b>Data for application in connection with Ex-areas</b> |  |
| EC-Type Examination Certificate                         | PTB 97 ATEX 1074 U, PTB 97 ATEX 1075 (system)  |
| Group, category, type of protection                     | ⊕ II 2 G Ex d II C   |
| Supply  | only in connection with the power supplies FB 92**                                       |
| Directive conformity                                    |  |
| Directive 94/9/EC                                       | EN 60079-0, EN 60079-1   |
| <b>International approvals</b>                          |  |
| IECEx approval  | pending  |

**Features**

- 1-channel
- Output wired to Ex e terminals
- Device installation in suitable enclosures in Zone 1 and Zone 21
- Analog output module for 0/4 mA ... 20 mA
- HART communication via field bus or service bus
- Module can be exchanged under voltage in Zone 1 (hot swap)
- Simulation mode for service operations (forcing)
- Line fault detection (LFD)
- Output with watchdog circuit
- Permanently self-monitoring
- EMC acc. to NAMUR NE 21
- Up to SIL2 acc. to IEC 61508

**Function**

The analog output drives positioners, proportional valves, I/P converters, or local indicators.

Open circuit line fault alarms are detected.

The output can be switched off via a contact. This can be used for bus-independent safety applications.

The output is galvanically isolated from the bus and the power supply (EN 60079-11).

**Diagrams**

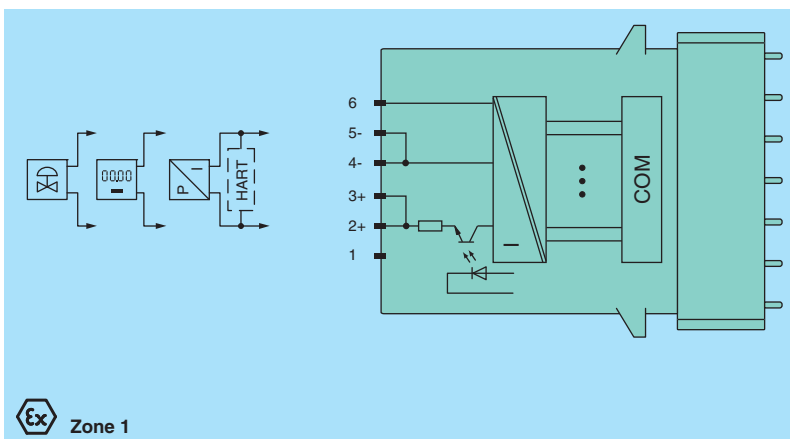

Front view

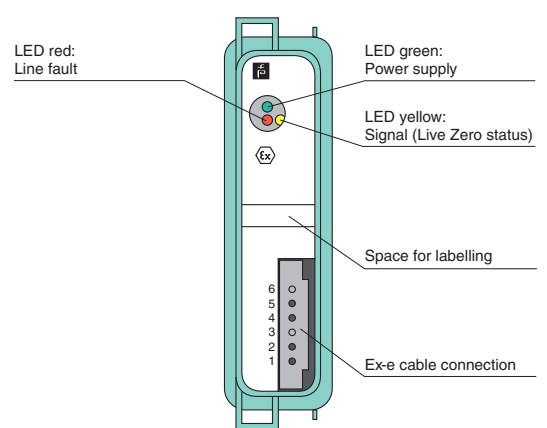

Edition 912907 (US) / 220718 (EU) 06/2011

Subject to modifications without notice

Pepperl+Fuchs Group  
www.pepperl-fuchs.com

USA: +1 330 486 0002  
pa-info@us.pepperl-fuchs.com

Germany: +49 621 776 2222  
pa-info@de.pepperl-fuchs.com

Copyright Pepperl+Fuchs  
Singapore: +65 6779 9091  
pa-info@sg.pepperl-fuchs.com



FB-System

Digital Inputs

Digital Outputs

Analog Inputs

Analog Outputs

Bus Couplers

Power Supplies

Accessories







FB-System

Digital Inputs

Digital Outputs

Analog Inputs

Analog Outputs

Bus Couplers

Power Supplies

Accessories



**Features**

- 4-channel
- Outputs wired to Ex e terminals
- Device installation in suitable enclosures in Zone 1 and Zone 21
- Analog output module for 0/4 mA ... 20 mA
- HART communication via field bus or service bus
- Module can be exchanged under voltage in Zone 1 (hot swap)
- Simulation mode for service operations (forcing)
- Line fault detection (LFD)
- Output with watchdog circuit
- Permanently self-monitoring
- EMC acc. to NAMUR NE 21
- Up to SIL2 acc. to IEC 61508

**Function**

The analog output drives positioners, proportional valves, I/P converters, or local indicators.

Open circuit line fault alarms are detected, depending on the parameter setting.

The outputs can be switched off via a contact. This can be used for bus-independent safety applications.

The outputs are galvanically isolated from the bus and the power supply (EN 60079-11).

**Technical data**

|   |  |
|---|--|
| <b>Supply</b>   |  |
| Connection  | backplane bus  |
| Rated voltage   | 12 V DC, only in connection with the power supplies FB 92**                              |
| Power consumption                                       | 3 W  |
| <b>Internal bus</b>                                     |  |
| Connection  | backplane bus  |
| Interface   | manufacturer specific bus to standard Com Unit/gateway                                   |
| <b>Output</b>   |  |
| Connection  | wire ends 1+ (white), 2- (brown), 3+ (green), 4- (yellow), 5+ (grey), 6- (pink)          |
| Current   | 4 ... 20 mA (0 ... 25 mA)<br>short circuit protected                                     |
| Load  | 750 Ω max.   |
| Line fault detection                                    | min. 1 mA  |
| Response threshold                                      | ≥ 850 Ω  |
| Watchdog  | output Off 0.5 s after serious fault   |
| <b>Ambient conditions</b>                               |  |
| Ambient temperature                                     | -20 ... 60 °C (-4 ... 140 °F)  |
| Storage temperature                                     | -25 ... 85 °C (-13 ... 185 °F)   |
| <b>Mechanical specifications</b>                        |  |
| Protection degree                                       | IP20 (module), a separate housing is required acc. to the system description             |
| Connection  | wire ends/cable tails<br>wiring connection<br>separately covered Ex-e terminals required |
| Mass  | approx. 750 g  |
| Dimensions  | 57 x 107 x 132 mm (2.2 x 4.2 x 5.2 in)   |
| <b>Data for application in connection with Ex-areas</b> | see page 242 for entity parameters   |
| EC-Type Examination Certificate                         | PTB 97 ATEX 1074 U, PTB 97 ATEX 1075 (system)  |
| Group, category, type of protection                     | ⊕ II 2 G Ex d II C   |
| Supply  | only in connection with the power supplies FB 92**                                       |
| Directive conformity                                    |  |
| Directive 94/9/EC                                       | EN 60079-0, EN 60079-1   |
| <b>International approvals</b>                          |  |
| IECEx approval  | pending  |

**Diagrams**

Front view

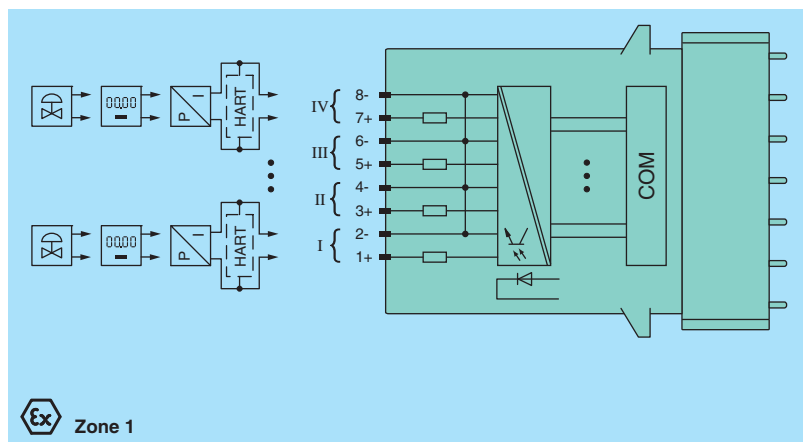
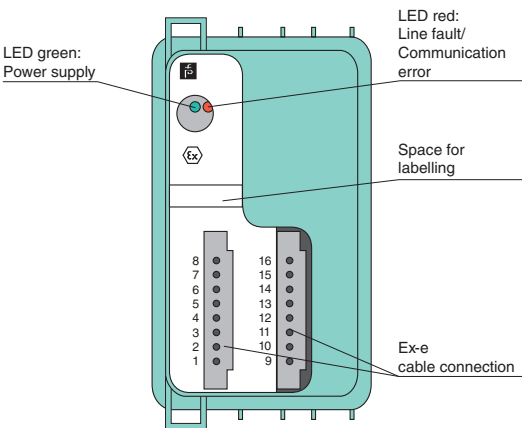

Edition 912907 (US) / 220718 (EU) 06/2011

| Technical data  |  |
|---|--|
| <b>Supply</b>   |  |
| Connection  | backplane bus  |
| Rated voltage   | 12 V DC, only in connection with the power supplies FB 92**                              |
| Power consumption                                       | 3 W  |
| <b>Internal bus</b>                                     |  |
| Connection  | backplane bus  |
| Interface   | manufacturer specific bus to standard Com Unit/gateway                                   |
| <b>Output</b>   |  |
| Connection  | wire ends 1+ (white), 2- (brown), 3+ (green), 4- (yellow), 5+ (grey), 6- (pink)          |
| Current   | 4 ... 20 mA (0 ... 25 mA)<br>short circuit protected                                     |
| Load  | 750 Ω max.   |
| Line fault detection                                    | min. 1 mA  |
| Response threshold                                      | ≥ 850 Ω  |
| Watchdog  | output Off 0.5 s after serious fault   |
| <b>Ambient conditions</b>                               |  |
| Ambient temperature                                     | -20 ... 60 °C (-4 ... 140 °F)  |
| Storage temperature                                     | -25 ... 85 °C (-13 ... 185 °F)   |
| <b>Mechanical specifications</b>                        |  |
| Protection degree                                       | IP20 (module), a separate housing is required acc. to the system description             |
| Connection  | wire ends/cable tails<br>wiring connection<br>separately covered Ex-e terminals required |
| Mass  | approx. 750 g  |
| Dimensions  | 57 x 107 x 132 mm (2.2 x 4.2 x 5.2 in)   |
| <b>Data for application in connection with Ex-areas</b> |  |
| EC-Type Examination Certificate                         | PTB 97 ATEX 1074 U, PTB 97 ATEX 1075 (system)  |
| Group, category, type of protection                     | ⊕ II 2 G Ex d II C   |
| Supply  | only in connection with the power supplies FB 92**                                       |
| Directive conformity                                    |  |
| Directive 94/9/EC                                       | EN 60079-0, EN 60079-1   |
| <b>International approvals</b>                          |  |
| IECEx approval  | pending  |

**Features**

- 4-channel
- Outputs wired to Ex e terminals
- Device installation in suitable enclosures in Zone 1 and Zone 21
- Analog output module for 0/4 mA ... 20 mA
- HART communication via field bus or service bus
- Module can be exchanged under voltage in Zone 1 (hot swap)
- Simulation mode for service operations (forcing)
- Line fault detection (LFD)
- Output with watchdog circuit
- Permanently self-monitoring
- EMC acc. to NAMUR NE 21

**Function**

The analog output drives positioners, proportional valves, I/P converters, or local indicators.

Open circuit line fault alarms are detected, depending on the parameter setting.

The outputs are galvanically isolated from the bus and the power supply (EN 60079-11).

**Diagrams**

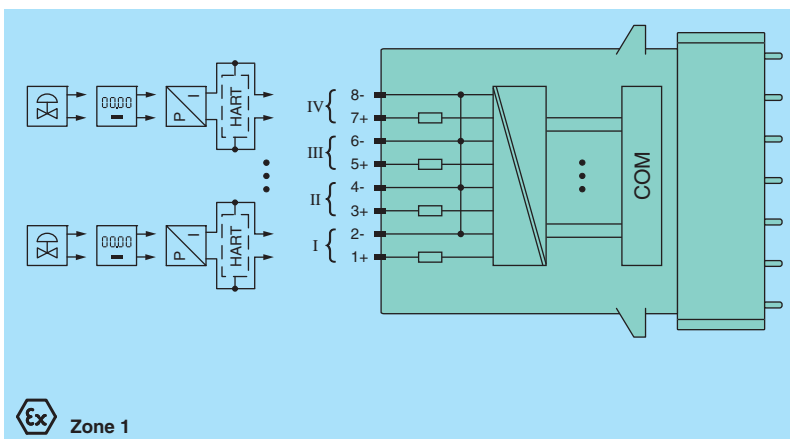

Front view

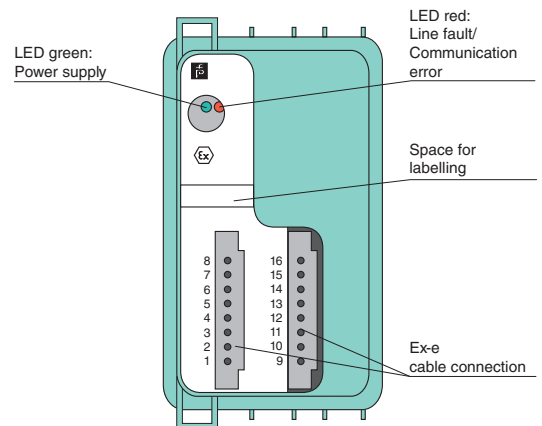

Edition 912907 (US) / 220718 (EU) 06/2011

Subject to modifications without notice

Pepperl+Fuchs Group  
www.pepperl-fuchs.com

USA: +1 330 486 0002  
pa-info@us.pepperl-fuchs.com

Germany: +49 621 776 2222  
pa-info@de.pepperl-fuchs.com

Copyright Pepperl+Fuchs  
Singapore: +65 6779 9091  
pa-info@sg.pepperl-fuchs.com

**PEPPERL+FUCHS 241**  
PROTECTING YOUR PROCESS



FB-System

Digital Inputs

Digital Outputs

Analog Inputs

Analog Outputs

Bus Couplers

Power Supplies

Accessories

## ATEX Entity Parameters

| Model Number | Terminals                      | $U_o$ (V) | $I_o$ (mA) | $P_o$ (mW) | $P_D$ (W) |
|--------------|--------------------------------|-----------|------------|------------|-----------|
| FB 4202 B    | 2, 3+, 4, 5-                   | 27.3      | 87         | 595        | 0.6       |
| FB 4202 C    | 2, 3+, 4, 5-                   | 27.3      | 87         | 595        | 0.6       |
| FB 4205 C    | 1+, 2-, 3+, 4-, 5+, 6-, 7+, 8- | 27.3      | 93         | 635        | 3.0       |
| FB 4205 D    | 1+, 2-, 3+, 4-, 5+, 6-, 7+, 8- | 27.3      | 93         | 635        | 3.0       |
| FB 4302 B    | 2, 3+, 4, 5-                   | –         | –          | –          | 0.6       |
| FB 4302 C    | 2, 3+, 4, 5-                   | –         | –          | –          | 0.6       |
| FB 4305 C    | 1+, 2-, 3+, 4-, 5+, 6-, 7+, 8- | –         | –          | –          | 3.0       |
| FB 4305 D    | 1+, 2-, 3+, 4-, 5+, 6-, 7+, 8- | –         | –          | –          | 3.0       |

## Bus Couplers (Gateways)

| Model Number              | Channels per Station <sup>1</sup> |         | Stations per Bus Line <sup>1</sup> |            |            |             |                      | Configuration |             |            |                    |   | Page |
|---------------------------|-----------------------------------|---------|------------------------------------|------------|------------|-------------|----------------------|---------------|-------------|------------|--------------------|---|------|
|                           | Analog                            | Digital | PROFIBUS DP V1                     | MODBUS RTU | MODBUS TCP | Fieldbus H1 | Service Bus (Option) | via GSD only  | via FDT 1.2 | via System | HART Communication | Mounting in Suitable Enclosures in Zone 1 and Zone 2 <sup>1</sup> |      |
| FB 8206 H***              | 80                                | 184     | 125                                |            |            |             | 119                  | ■             |             | ■          | ■                  | ■   | 244  |
| FB 8207 H***              | 80                                | 184     |                                    | 245        |            |             | 119                  |               | ■           |            | ■                  | ■   | 245  |
| FB 8209 H*** <sup>2</sup> | 80                                | 184     | 125                                |            |            |             | 119                  |               | ■           | □          | ■                  | ■   | 246  |
| FB 8210 H***              | 20                                | 40      |                                    |            |            | 1 or 2      | 119                  |               |             | ■          | ■                  | ■   | 247  |
| FB 8211 A                 | 80                                | 184     |                                    |            | 1          |             |                      |               | ■           | □          | ■                  | ■   | 248  |

□ depending on the DCS

■ available

<sup>1</sup> see data sheet for details<sup>2</sup> FB 8209 H\*\*\* compatible replacement for FB 8205 H\*\*\* (spares available) – extended functionality

FB-System

Digital Inputs

Digital Outputs

Analog Inputs

Analog Outputs

Bus Couplers

Power Supplies

Accessories



FB-System

Digital Inputs

Digital Outputs

Analog Inputs

Analog Outputs

Bus Couplers

Power Supplies

Accessories

**Features**

- Interface between the I/O modules and the DCS/PLC
- Bus coupler for 80 analog or 184 digital channels
- Communication via PROFIBUS DP
- HART communication via PROFIBUS DP V1 or service bus
- Configuration via GSD parameters from the control system
- Non-volatile memory for configuration and parameter settings
- Module can be exchanged under voltage in Zone 1 (hot swap)
- Installation in suitable enclosures in Zone 1 and Zone 21
- EMC acc. to NAMUR NE 21

**Function**

The Remote I/O ComUnit, bus coupler or gateway links intrinsically safe and safe inputs and outputs from sensors and actuators to the PROFIBUS.

It makes use of all the regular I/O modules and thus transports signals to and from NAMUR and switch type inputs and high power IS solenoids or even power relays as well as sounders, and alarm LEDs.

The system supplies 4-20 mA transmitters and accepts inputs from 20 mA current sources or temperature sensors. It drives I/P converters and proportional valves and positioners.

The ComUnit supports ONLINE configuration as well as redundancy and HART. It is well integrated into all renowned DCS and PLC systems.

**Technical data**

**Supply**

Rated voltage 5 V DC, only in connection with the power supplies FB 92\*\*

Power consumption 2 W

**Fieldbus interface**

**PROFIBUS DP**

Baud rate up to 1.5 MBit/s  
 Protocol PROFIBUS DP/DP V1 read/write services  
 Number of stations per bus line ≤ 125 (PROFIBUS), ≤ 119 (service bus)  
 Number of channels per station ≤ 80 analog, ≤ 184 digital (standard configuration)  
 Number of stations per bus segment ≤ 31 (RS 485 standard)  
 Supported I/O modules all FB Remote I/O modules  
 Bus length ≤ 1000 m (FOL, 1.5 MBaud), ≤ 1000 m (copper cable, 187.5 kBd), ≤ 200 m (copper cable, 1.5 MBd)

Addressing via configuration software  
 PROFIBUS address 0 ... 126 (ex works standard: 126)  
 GSE file CGV61711.gsd/gse  
 HART communication via PROFIBUS or service bus

**Internal bus**

Connection backplane bus  
 Redundancy via front connector

**Ambient conditions**

Ambient temperature -20 ... 60 °C (-4 ... 140 °F)  
 Storage temperature -25 ... 85 °C (-13 ... 185 °F)

**Mechanical specifications**

Protection degree IP20 (module), a separate housing is required acc. to the system description  
 Connection via backplane  
 Mass approx. 750 g  
 Dimensions 57 x 107 x 132 mm (2.2 x 4.2 x 5.2 in)

**Data for application in connection with Ex-areas**

EC-Type Examination Certificate PTB 97 ATEX 1074 U, PTB 97 ATEX 1075 (system)  
 Group, category, type of protection Ex II 2 (1) G Ex d [ia] IIC  
 Supply only in connection with the power supplies FB 92\*\*  
 Directive conformity  
 Directive 94/9/EC EN 60079-0, EN 60079-1, EN 60079-11, EN 60079-26

**International approvals**

IECEx approval pending

**Diagrams**

Front view

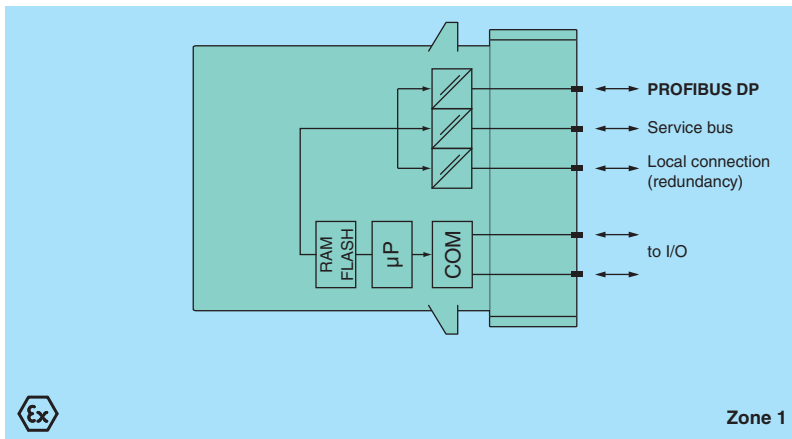
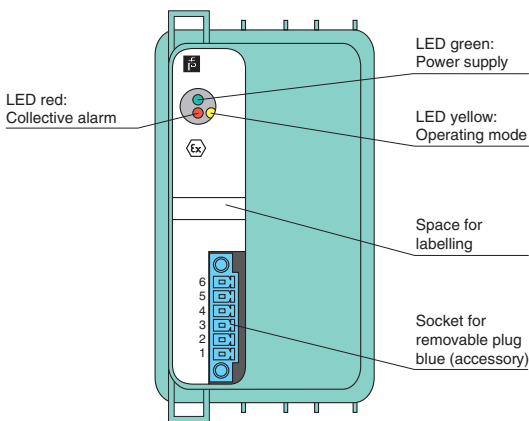

| Technical data  |  |
|---|--|
| <b>Supply</b>   |  |
| Rated voltage   | 5 V DC, only in connection with the power supplies FB 92**                   |
| Power consumption                                       | 2 W  |
| <b>Fieldbus interface</b>                               |  |
| MODBUS RTU  |  |
| Baud rate   | max. 38.4 kBit/s   |
| Number of stations per bus line                         | ≤245 (MODBUS), ≤ 119 (service bus)   |
| Number of channels per station                          | ≤80 analog, ≤ 184 digital (standard configuration)                           |
| Number of stations per bus segment                      | ≤31 (RS 485 standard)  |
| Supported I/O modules                                   | all FB Remote I/O modules  |
| Bus length  | ≤ 1200 m (FOL, 38.4 kBd),<br>≤ 1200 m (copper cable, 38.4 kBd)               |
| FOL (fibre optic link)                                  | additional hardware required   |
| Addressing  | via configuration software   |
| MODBUS address  | standard compliant (ex works standard: 126)                                  |
| Service bus address                                     | max. 119, redundant address = base + 128 (automatic)                         |
| HART communication                                      | via service bus  |
| Redundancy  | system dependent   |
| <b>Internal bus</b>                                     |  |
| Connection  | backplane bus  |
| Redundancy  | via front connector  |
| <b>Ambient conditions</b>                               |  |
| Ambient temperature                                     | -20 ... 60 °C (-4 ... 140 °F)  |
| Storage temperature                                     | -25 ... 85 °C (-13 ... 185 °F)   |
| <b>Mechanical specifications</b>                        |  |
| Protection degree                                       | IP20 (module), a separate housing is required acc. to the system description |
| Connection  | via backplane  |
| Mass  | approx. 750 g  |
| Dimensions  | 57 x 107 x 132 mm (2.2 x 4.2 x 5.2 in)                                       |
| <b>Data for application in connection with Ex-areas</b> |  |
| EC-Type Examination Certificate                         | PTB 97 ATEX 1074 U, PTB 97 ATEX 1075 (system)                                |
| Group, category, type of protection                     | ⊕ II 2 (1) G Ex d [ia] IIC   |
| Supply  | only in connection with the power supplies FB 92**                           |
| Directive conformity                                    |  |
| Directive 94/9/EC                                       | EN 60079-0, EN 60079-1, EN 60079-11, EN 60079-26                             |
| <b>International approvals</b>                          |  |
| IECEX approval  | pending  |

Features

- Interface between the I/O modules and the DCS/PLC
- Bus coupler for 80 analog or 184 digital channels
- Communication via MODBUS RTU
- HART communication via service bus
- Configuration via FDT 1.2 DTM
- Non-volatile memory for configuration and parameter settings
- Module can be exchanged under voltage in Zone 1 (hot swap)
- Installation in suitable enclosures in Zone 1 and Zone 21
- EMC acc. to NAMUR NE 21

Function

The Remote I/O ComUnit, bus coupler or gateway links intrinsically safe and safe inputs and outputs from sensors and actuators to the Modbus.

It makes use of all the regular I/O modules and thus transports signals to and from NAMUR and switch type inputs and high power IS solenoids or even power relays as well as sounders, and alarm LEDs.

The system supplies 4-20 mA transmitters and accepts inputs from 20 mA current sources or temperature sensors. It drives I/P converters and proportional valves and positioners.

The ComUnit supports ONLINE configuration as well as redundancy and HART. It is well integrated into all renowned DCS and PLC systems.

Diagrams

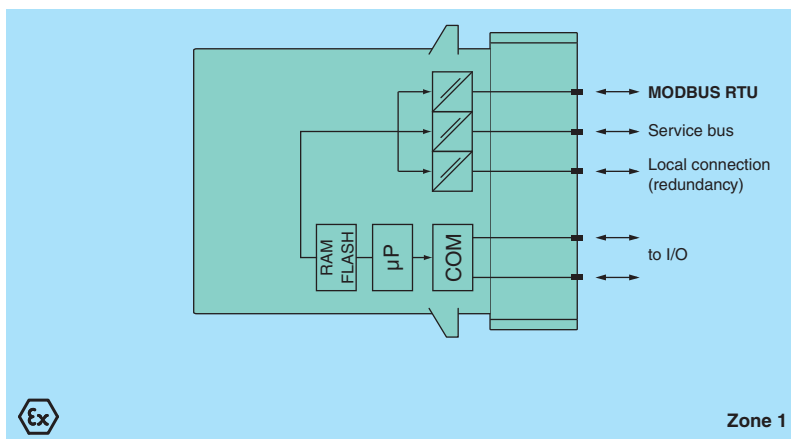

Front view

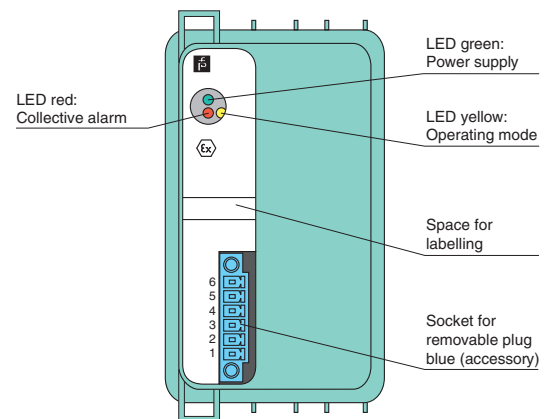

FB-System

Digital Inputs

Digital Outputs

Analog Inputs

Analog Outputs

Bus Couplers

Power Supplies

Accessories

Edition 912907 (US) / 220718 (EU) 06/2011

Subject to modifications without notice

Pepperl+Fuchs Group  
www.pepperl-fuchs.com

USA: +1 330 486 0002  
pa-info@us.pepperl-fuchs.com

Germany: +49 621 776 2222  
pa-info@de.pepperl-fuchs.com

Copyright Pepperl+Fuchs  
Singapore: +65 6779 9091  
pa-info@sg.pepperl-fuchs.com

**PEPPERL+FUCHS 245**  
PROTECTING YOUR PROCESS

FB-System  
Digital Inputs  
Digital Outputs  
Analog Inputs  
Analog Outputs  
Bus Couplers  
Power Supplies  
Accessories

**Features**

- Interface between the I/O modules and the DCS/PLC
- Bus coupler for 80 analog or 184 digital channels
- HART communication via PROFIBUS DP V1 or service bus
- Non-volatile memory for configuration and parameter settings
- Module can be exchanged under voltage in Zone 1 (hot swap)
- Installation in suitable enclosures in Zone 1 and Zone 21
- EMC acc. to NAMUR NE 21

**Function**

The Remote I/O ComUnit, bus coupler or gateway links intrinsically safe and safe inputs and outputs from sensors and actuators to the PROFIBUS.

It makes use of all the regular I/O modules and thus transports signals to and from NAMUR and switch type inputs and high power IS solenoids or even power relays as well as sounders, and alarm LEDs.

The system supplies 4-20 mA transmitters and accepts inputs from 20 mA current sources or temperature sensors. It drives I/P converters and proportional valves and positioners.

The ComUnit supports ONLINE configuration as well as redundancy and HART. It is well integrated into all renowned DCS and PLC systems.

A universal setting allows you to configure a running system without a PROFIBUS restart even in non-redundant systems (CiR functionality).

**Technical data**

|   |  |
|---|--|
| <b>Supply</b>   |  |
| Rated voltage   | 5 V DC, only in connection with the power supplies FB 92**   |
| Power consumption                                       | 2 W  |
| <b>Fieldbus interface</b>                               |  |
| PROFIBUS DP   |  |
| Baud rate   | up to 1.5 MBit/s   |
| Protocol  | PROFIBUS DP/DP V1 read/write services  |
| Number of stations per bus line                         | ≤ 125 (PROFIBUS), ≤ 119 (service bus)  |
| Number of channels per station                          | ≤ 80 analog, ≤ 184 digital (standard configuration)  |
| Number of stations per bus segment                      | ≤ 31 (RS 485 standard)   |
| Supported I/O modules                                   | all FB Remote I/O modules  |
| Configuration (240 bytes I/O)                           | Standard: 80 analog, 184 digital<br>Universal 2I2O: 48 analog, 184 digital<br>Universal 4I4O: 60 analog, 120 digital |
| Bus length  | ≤ 1000 m (FOL, 1.5 MBaud),<br>≤ 1000 m (copper cable, 187.5 kBd),<br>≤ 200 m (copper cable, 1.5 MBd)                 |
| Addressing  | via configuration software   |
| PROFIBUS address  | 0 ... 126 (ex works standard: 126)   |
| <b>Internal bus</b>                                     |  |
| Connection  | backplane bus  |
| Redundancy  | via front connector  |
| <b>Ambient conditions</b>                               |  |
| Ambient temperature                                     | -20 ... 60 °C (-4 ... 140 °F)  |
| Storage temperature                                     | -25 ... 85 °C (-13 ... 185 °F)   |
| <b>Mechanical specifications</b>                        |  |
| Protection degree                                       | IP20 (module), a separate housing is required acc. to the system description   |
| Connection  | via backplane  |
| Mass  | approx. 750 g  |
| Dimensions  | 57 x 107 x 132 mm (2.2 x 4.2 x 5.2 in)   |
| <b>Data for application in connection with Ex-areas</b> |  |
| EC-Type Examination Certificate                         | PTB 97 ATEX 1074 U, PTB 97 ATEX 1075 (system)  |
| Group, category, type of protection                     | ⊕ II 2 (1) G Ex d [ia] IIC   |
| Supply  | only in connection with the power supplies FB 92**   |
| Directive conformity                                    |  |
| Directive 94/9/EC                                       | EN 60079-0, EN 60079-1, EN 60079-11, EN 60079-26   |
| <b>International approvals</b>                          |  |
| IECEx approval  | pending  |

**Diagrams**

Front view

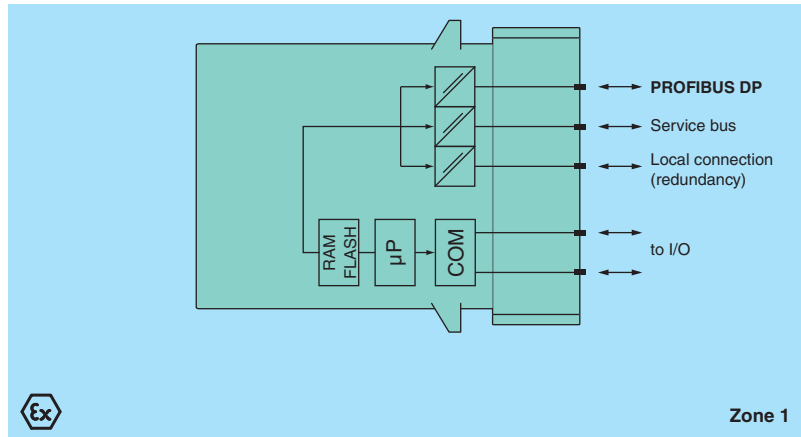
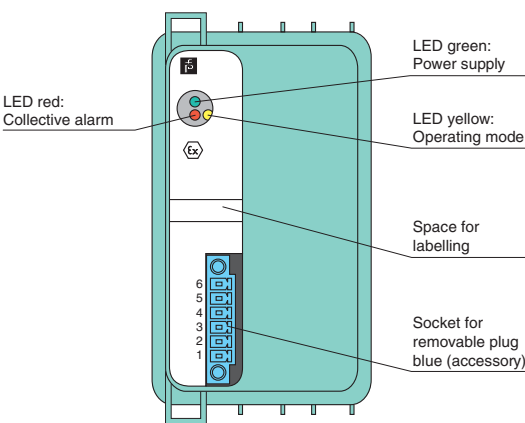



FB-System

Digital Inputs

Digital Outputs

Analog Inputs

Analog Outputs

Bus Couplers

Power Supplies

Accessories

| Technical data  |  |
|---|--|
| <b>Supply</b>   |  |
| Rated voltage   | 5 V DC, only in connection with the power supplies FB 92**   |
| <b>Fieldbus interface</b>                               |  |
| FOUNDATION Fieldbus                                     |  |
| Baud rate   | 31.25 kBit/s, MBP  |
| Number of stations per bus line                         | 1 or 2, depending on the required response times   |
| Number of channels per station                          | ≤20 analog, ≤40 digital  |
| Supported I/O modules                                   | 5 slots, to be filled with (combinations possible):<br>1*08 digital input, 8-channel, NAMUR<br>3204 analog input, 4-channel, 20 mA (HART via handheld only), 3*05 analog input, 4-channel, 20 mA (HART via service bus)<br>4204 analog output, 4-channel, 20 mA (HART via handheld), 4*05 analog output, 4-channel, 20 mA (HART via service bus)<br>5204 Pt100 RTD input, 4-channel<br>5205 thermocouple input, 4-channel<br>6305 relay output, 4-channel, 230 V<br>6306 relay output, 8-channel, 24 V<br>6*08 digital output, 8-channel<br>6210-6215 digital output, 4-channel, Ex-i power<br>* = variable (2 = IS, 3 = Ex-e) |
| Bus length  | ≤1900 m (must not be exceeded by the sum of all trunk and spur lines)  |
| Spur length   | ≤120 m (depending on the number of field devices.<br>Modular I/O station = 1 field device)   |
| <b>Ambient conditions</b>                               |  |
| Ambient temperature                                     | -20 ... 60 °C (-4 ... 140 °F)  |
| <b>Mechanical specifications</b>                        |  |
| Protection degree                                       | IP20 (module), a separate housing is required acc. to the system description   |
| Connection  | via backplane  |
| Mass  | approx. 750 g  |
| Dimensions  | 57 x 107 x 132 mm (2.2 x 4.2 x 5.2 in)   |
| <b>Data for application in connection with Ex-areas</b> |  |
| EC-Type Examination Certificate                         | PTB 97 ATEX 1074 U, PTB 97 ATEX 1075 (system)  |
| Group, category, type of protection                     | ⊕ II 2 G Ex d II C   |
| Supply  | only in connection with the power supplies FB 92**   |
| <b>Directive conformity</b>                             |  |
| Directive 94/9/EC                                       | EN 60079-0, EN 60079-1   |
| <b>International approvals</b>                          |  |
| IECEx approval  | pending  |

**Features**

- Interface between the I/O modules and the DCS/PLC
- Bus coupler for 20 analog or 40 digital channels
- Communication via FOUNDATION fieldbus H1
- HART communication via service bus
- Non-volatile memory for configuration and parameter settings
- Module can be exchanged under voltage in Zone 1 (hot swap)
- Supports multichannel I/O modules
- Installation in suitable enclosures in Zone 1 and Zone 21
- EMC acc. to NAMUR NE 21

**Function**

The ComUnit, bus coupler or gateway links intrinsically safe inputs and outputs from sensors and actuators to FOUNDATION Fieldbus.

It makes use of dual width I/O modules and thus transports signals from NAMUR and switch type inputs and high power IS solenoids or even power relays as well as sounders, and alarm LEDs.

The system supplies 4-20 mA transmitters and accepts inputs from 20 mA current sources or temperature sensors. It drives I/P converters and proportional valves and positioners.

The ComUnit supports ONLINE configuration as well as HART. It is well integrated into renowned DCS and PLC systems.

**Diagrams**

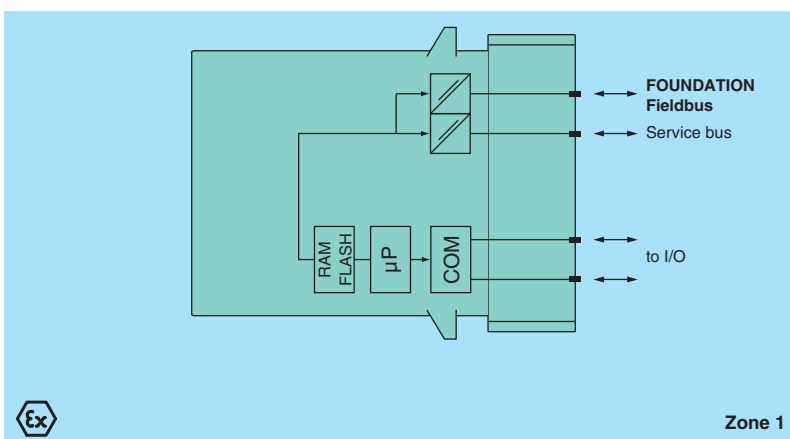

Front view

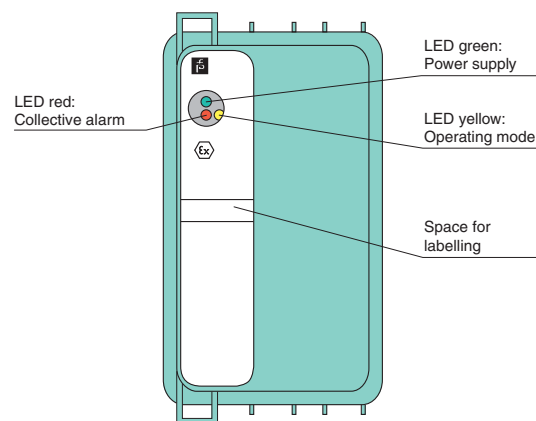

Edition 912907 (US) / 220718 (EU) 06/2011

Subject to modifications without notice

Pepperl+Fuchs Group  
www.pepperl-fuchs.com

USA: +1 330 486 0002  
pa-info@us.pepperl-fuchs.com

Germany: +49 621 776 2222  
pa-info@de.pepperl-fuchs.com

Copyright Pepperl+Fuchs  
Singapore: +65 6779 9091  
pa-info@sg.pepperl-fuchs.com





FB-System

Digital Inputs

Digital Outputs

Analog Inputs

Analog Outputs

Bus Couplers

Power Supplies

Accessories

**Features**

- Interface between the I/O modules and the DCS/PLC
- Bus coupler for 80 analog or 184 digital channels
- Communication via MODBUS TCP
- HART communication via MODBUS TCP or service bus
- Configuration via FDT 1.2 DTM
- Non-volatile memory for configuration and parameter settings
- Module can be exchanged under voltage in Zone 1 (hot swap)
- Installation in suitable enclosures in Zone 1 and Zone 21
- EMC acc. to NAMUR NE 21

**Function**

The Modbus TCP Remote I/O ComUnit or gateway brings intrinsically safe inputs and outputs from sensors and actuators to the Ethernet.

It makes use of all the regular I/O modules and thus transports signals to and from NAMUR and switch type inputs and high power IS solenoids or even power relays as well as sounders, and alarm LEDs.

The system supplies 4-20 mA transmitters and accepts inputs from 20 mA current sources or temperature sensors. It drives I/P converters and proportional valves and positioners.

Industrial Ethernet hardware is familiar to most users not only through office applications but also through the architecture on which DCS systems are based.

**Technical data**

|   |  |
|---|--|
| <b>Supply</b>   |  |
| Rated voltage   | 5 V DC, only in connection with the power supplies FB 92**                   |
| Power consumption                                       | 2.5 W  |
| <b>Ethernet Interface</b>                               |  |
| Connection type   | wired to Ex-e terminals via backplane  |
| Transfer rate   | 10 MBit/s  |
| Station connection                                      | directly to DCS or PLC or via hubs or switches                               |
| Bus length  | ≤ 100 m (Ethernet standard)  |
| Addressing  | IP address assigned via Ethernet   |
| Ethernet address  | IP V4 address<br>(ex works standard: 0.0.0.0, auto IP, DHCP)                 |
| Number of channels per station                          | ≤ 80 analog, ≤ 184 digital   |
| Supported I/O modules                                   | all FB Remote I/O modules  |
| <b>Internal bus</b>                                     |  |
| Connection  | backplane bus  |
| Redundancy  | via front connector  |
| <b>Service interface</b>                                |  |
| Connection  | service adapter  |
| <b>Ambient conditions</b>                               |  |
| Ambient temperature                                     | -20 ... 60 °C (-4 ... 140 °F)  |
| Storage temperature                                     | -25 ... 85 °C (-13 ... 185 °F)   |
| <b>Mechanical specifications</b>                        |  |
| Protection degree                                       | IP20 (module), a separate housing is required acc. to the system description |
| Connection  | via backplane  |
| Mass  | approx. 750 g  |
| Dimensions  | 57 x 107 x 132 mm (2.2 x 4.2 x 5.2 in)                                       |
| <b>Data for application in connection with Ex-areas</b> |  |
| EC-Type Examination Certificate                         | PTB 97 ATEX 1074 U, PTB 97 ATEX 1075 (system)                                |
| Group, category, type of protection                     | ⊕ II 2 (1) G Ex d [ia] IIC   |
| Supply  | only in connection with the power supplies FB 92**                           |
| <b>Directive conformity</b>                             |  |
| Directive 94/9/EC                                       | EN 60079-0, EN 60079-1, EN 60079-11, EN 60079-26                             |
| <b>International approvals</b>                          |  |
| IECEx approval  | pending  |

**Diagrams**

Front view

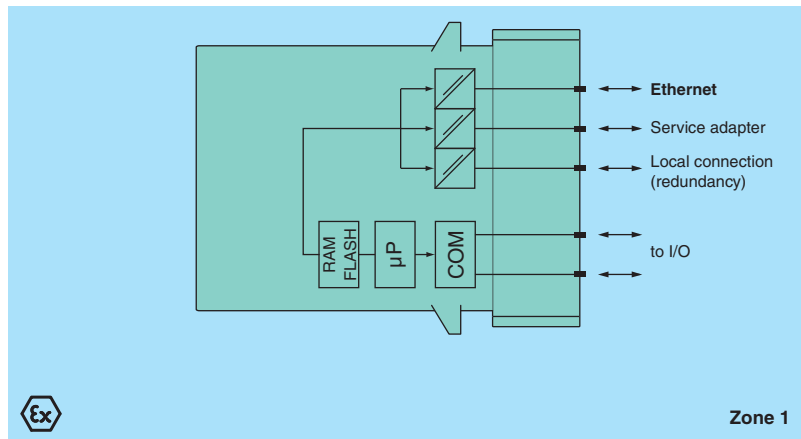
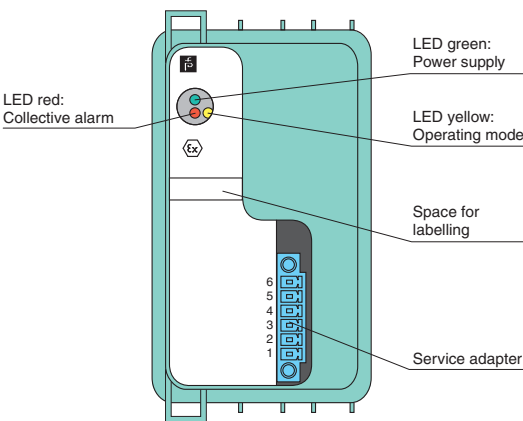

Edition 912907 (US) / 220718 (EU) 06/2011

Power Supplies

| Model Number | Supplied Devices |              |                     | Supply  |          |          | Redundant Supply Possible | Mounting in Suitable Enclosures in Zone 1 and Zone 21 | Page |
|--------------|------------------|--------------|---------------------|---------|----------|----------|---------------------------|---|------|
|              | I/O Module Slots | Bus Couplers | Other Field Devices | 24 V DC | 115 V AC | 230 V AC |                           |   |      |
| FB 9205 C    |                  |              | ■                   |         |          | ■        | ■                         | ■   | 250  |
| FB 9206 D    | 24               | 1            |                     | ■       |          |          | ■                         | ■   | 251  |
| FB 9215 B    | 24               | 1            |                     |         |          | ■        |                           | ■   | 252  |
| FB 9216 B    | 24               | 1            |                     |         | ■        |          |                           | ■   | 252  |



FB-System

Digital Inputs

Digital Outputs

Analog Inputs

Analog Outputs

Bus Couplers

Power Supplies

Accessories

Edition 912907 (US) / 220718 (EU) 06/2011





FB-System

Digital Inputs

Digital Outputs

Analog Inputs

Analog Outputs

Bus Couplers

Power Supplies

Accessories

**Features**

- Power supply for 95 - 230 V AC
- Suitable for the supply of FOL, field products (analyzers, level meters etc.)
- Use two power supplies for redundancy
- Installation in suitable enclosures in Zone 1 and Zone 21
- Module can be exchanged under voltage in Zone 1 (hot swap)
- Galvanic isolation to mains
- EMC acc. to NAMUR NE 21

**Function**

The power supply provides power for 24V DC consumers.  
 Two power supplies can be connected in parallel using their diode decoupled outputs in order to achieve redundancy.  
 Input and output are galvanically isolated from each other (EN 60950-1).  
 This power supply replaces power supply FB9205B.

**Technical data**

|   |  |
|---|--|
| <b>Supply</b>   |  |
| Connection  | wired to Ex-e terminals  |
| Rated voltage   | 95 ... 230 V AC  |
| Power consumption                                       | max. 45 VA   |
| Inrush current  | 3.4 A (10 ms)  |
| <b>Electrical specifications</b>                        |  |
| Fusing  | 1.25 A T   |
| <b>Output</b>   |  |
| Current   | 1.2 A  |
| Voltage   | 24 V DC +/- 3% (Connectors 5, 12)<br>23 V DC +/- 3% decoupled via diode (Connectors 5, 13) |
| <b>Ambient conditions</b>                               |  |
| Ambient temperature                                     | -20 ... 60 °C (-4 ... 140 °F)  |
| Storage temperature                                     | -25 ... 85 °C (-13 ... 185 °F)   |
| <b>Mechanical specifications</b>                        |  |
| Protection degree                                       | IP20 (module), a separate housing is required acc. to the system description               |
| Mass  | approx. 750 g  |
| Dimensions  | 57 x 107 x 132 mm (2.2 x 4.2 x 5.2 in)   |
| <b>Data for application in connection with Ex-areas</b> |  |
| EC-Type Examination Certificate                         | PTB 97 ATEX 1074 U, PTB 97 ATEX 1075 (system)  |
| Group, category, type of protection                     | ⊕ II 2 G Ex d II C   |
| Directive conformity                                    |  |
| Directive 94/9/EC                                       | EN 60079-0, EN 60079-1   |
| <b>International approvals</b>                          |  |
| IECEx approval  | pending  |

**Diagrams**

Front view

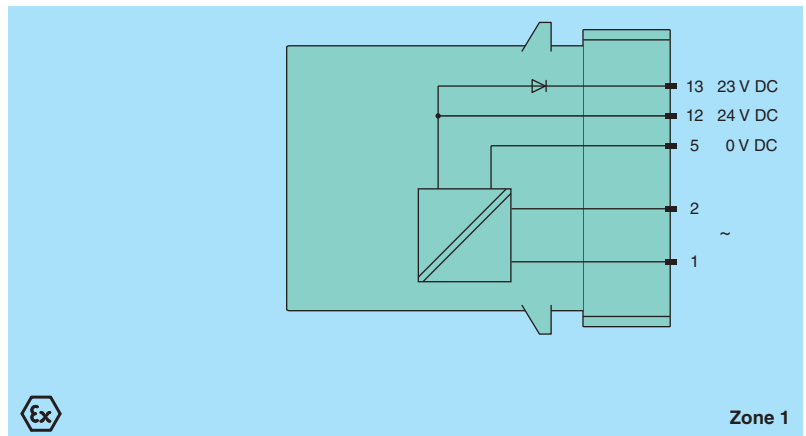
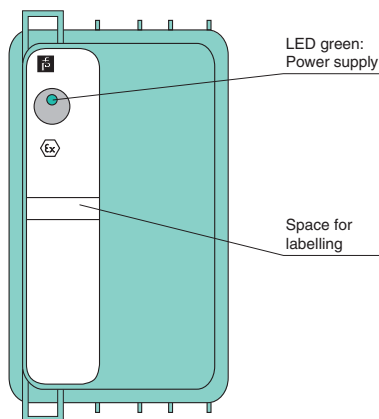

Edition 912907 (US) / 220718 (EU) 06/2011

| Technical data  |  |
|---|--|
| <b>Supply</b>   |  |
| Connection  | wired to Ex-e terminals via backplane  |
| Rated voltage   | 24 V DC (18 - 32 V DC)   |
| Power dissipation                                       | ca. 12% of power consumption   |
| Power consumption                                       | ≤ 47 W, parallel connection with other FB 9206 D (autom. power sharing)      |
| Inrush current  | 1.5 A (10 ms)  |
| <b>Electrical specifications</b>                        |  |
| Fusing  | 4 A mtg (internal), 5 A mtg (external)                                       |
| <b>Output</b>   |  |
| Voltage   | 5 V DC +/- 5%,<br>12 V DC + 4/- 2%   |
| Power   | 5 W (5 V), 35 W (12 V)   |
| <b>Ambient conditions</b>                               |  |
| Ambient temperature                                     | -20 ... 60 °C (-4 ... 140 °F)  |
| Storage temperature                                     | -25 ... 85 °C (-13 ... 185 °F)   |
| <b>Mechanical specifications</b>                        |  |
| Protection degree                                       | IP20 (module), a separate housing is required acc. to the system description |
| Mass  | approx. 820 g  |
| Dimensions  | 57 x 107 x 132 mm (2.2 x 4.2 x 5.2 in)                                       |
| <b>Data for application in connection with Ex-areas</b> |  |
| EC-Type Examination Certificate                         | PTB 97 ATEX 1074 U, PTB 97 ATEX 1075 (system)                                |
| Group, category, type of protection                     | ⊕ II 2 G Ex d II C   |
| <b>Directive conformity</b>                             |  |
| Directive 94/9/EC                                       | EN 60079-0, EN 60079-1   |
| <b>International approvals</b>                          |  |
| IECEx approval  | pending  |

**Features**

- Succeeds FB 9206 B
- Power supply for 24 V DC
- Suitable for the supply of 24 I/O modules and 1 bus coupler
- Use two power supplies for redundancy
- Installation in suitable enclosures in Zone 1 and Zone 21
- Module can be exchanged under voltage in Zone 1 (hot swap)
- EMC acc. to NAMUR NE 21

**Function**

The power supply provides power for the I/O modules and com units mounted on the backplane.  
Power supplies can be connected in parallel to achieve redundancy.  
Input and output are galvanically isolated from each other (EN 61010-1).  
This power supply is a fully compatible replacement for FB9206B.

**Diagrams**

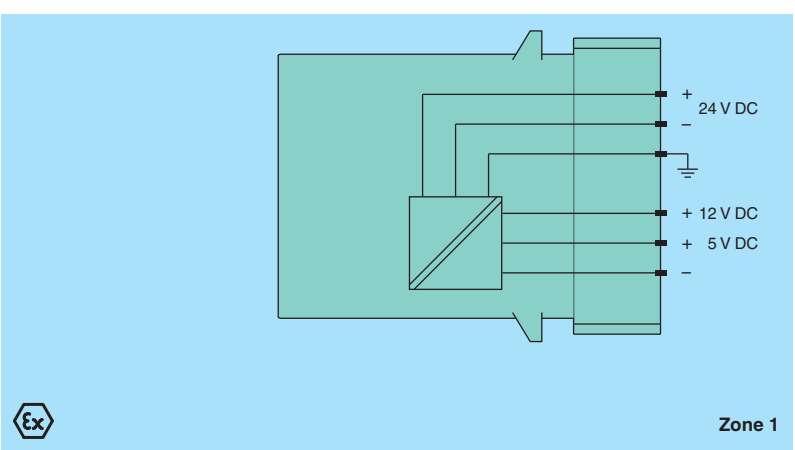

Front view

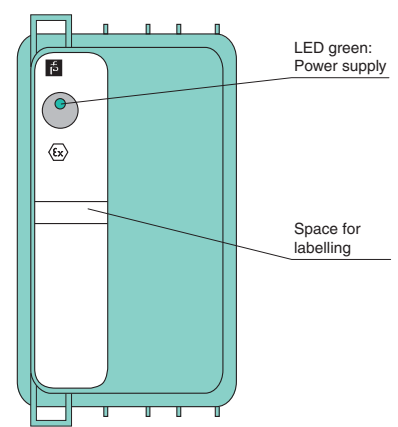

Edition 912907 (US) / 220718 (EU) 06/2011



FB-System

Digital Inputs

Digital Outputs

Analog Inputs

Analog Outputs

Bus Couplers

Power Supplies

Accessories

**Features**

- Power supply for 115/230V AC
- Suitable for the supply of 24 I/O modules and 1 bus coupler
- Installation in suitable enclosures in Zone 1 and Zone 21
- Module can be exchanged under voltage in Zone 1 (hot swap)
- EMC acc. to NAMUR NE 21

**Function**

The power supply provides power for the I/O modules and com units mounted on the backplane.

Input and output are galvanically isolated from each other (EN 60950-1).

**Technical data**

|   |  |
|---|--|
| <b>Supply</b>   |  |
| Connection  | wired to Ex-e terminals via backplane  |
| Rated voltage   | 230 V AC (+10% - 15%) FB 9215<br>115 V AC (100 ... 132 V) FB 9216            |
| Power consumption                                       | ≤ 35 VA  |
| Inrush current  | 15 A (20 ms)   |
| <b>Electrical specifications</b>                        |  |
| Fusing  | 3.15 A mtg or 1 A T (internal)   |
| <b>Output</b>   |  |
| Voltage   | 5 V DC +/- 5%,<br>12 V DC + 4/- 2%   |
| Power   | 2 W (5 V), 30 VA (12 V)  |
| <b>Ambient conditions</b>                               |  |
| Ambient temperature                                     | -20 ... 60 °C (-4 ... 140 °F)  |
| Storage temperature                                     | -25 ... 85 °C (-13 ... 185 °F)   |
| <b>Mechanical specifications</b>                        |  |
| Protection degree                                       | IP20 (module), a separate housing is required acc. to the system description |
| Mass  | approx. 750 g  |
| Dimensions  | 57 x 107 x 132 mm (2.2 x 4.2 x 5.2 in)                                       |
| <b>Data for application in connection with Ex-areas</b> |  |
| EC-Type Examination Certificate                         | PTB 97 ATEX 1074 U, PTB 97 ATEX 1075 (system)                                |
| Group, category, type of protection                     | Ex II 2 G Ex d II C  |
| Directive conformity                                    |  |
| Directive 94/9/EC                                       | EN 60079-0, EN 60079-1   |
| <b>International approvals</b>                          |  |
| IECEX approval  | pending  |

**Diagrams**

Front view

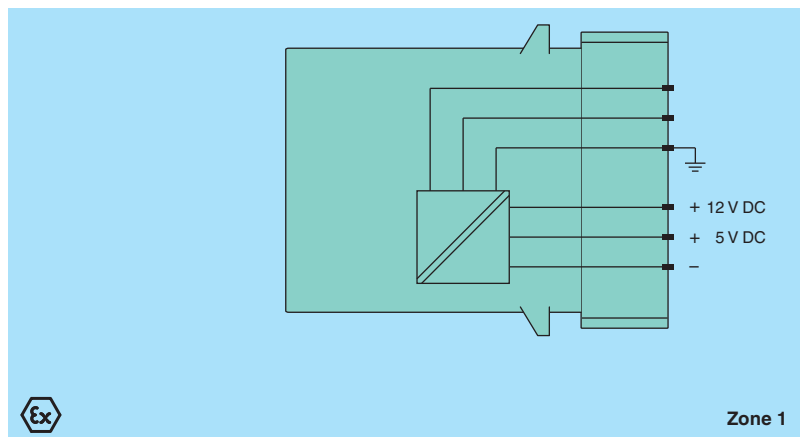
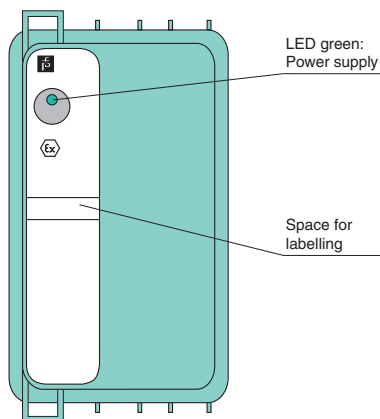

Edition 912907 (US) / 220718 (EU) 06/2011

## Bus Termination Modules

| Model Number | Description   | Page |
|--------------|---|------|
| FB 9293 B    | Bus Termination Module, service bus termination         | 255  |
| FB 9294 B    | Bus Termination Module, bus termination                 | 255  |
| FB 9295 B    | Bus Termination Module, bus and service bus termination | 255  |

## Terminal Blocks

| Model Number | Terminal Block       |                           |                            |                      |                                 |                     |   |                 | Page |                    |
|--------------|----------------------|---------------------------|----------------------------|----------------------|---------------------------------|---------------------|---|-----------------|------|--------------------|
|              | with Screw Terminals | with Wire Clamp Terminals | with Front Screw Terminals | Cold Junction Module | Voltage Divider for 10 V Inputs | Labeled             | Cover for Terminal Block with Screw Terminals | Number of Poles |      | Housing Color Blue |
| LB 9107 A    | ■                    |                           |                            |                      |                                 | 1 ... 6             |   | 6               | ■    | 256                |
| LB 9107 P    |                      | ■                         |                            |                      |                                 | 1 ... 6             |   | 6               | ■    | 256                |
| LB 9108 A    |                      |                           |                            |                      |                                 |                     | ■   | 6               | ■    | 256                |
| LB 9112 A    |                      |                           |                            | ■                    |                                 | 1 ... 6             |   | 6               | ■    | 256                |
| LB 9113 A    | ■                    |                           |                            |                      |                                 | 1 ... 8             |   | 8               | ■    | 256                |
| LB 9115 A    |                      | ■                         |                            |                      |                                 | 1 ... 8             |   | 8               | ■    | 256                |
| LB 9116 A    |                      | ■                         |                            |                      |                                 | 1 ... 8<br>9 ... 16 |   | 2 x 8           | ■    | 256                |
| LB 9117 A    |                      |                           | ■                          |                      |                                 | 1 ... 6             |   | 6               | ■    | 256                |
| LB 9118 A    |                      |                           | ■                          |                      |                                 | 1 ... 8             |   | 8               | ■    | 256                |
| LB 9119 A    |                      |                           | ■                          |                      |                                 | 1 ... 8<br>9 ... 16 |   | 2 x 8           | ■    | 256                |
| LB 9120 A    |                      |                           |                            |                      |                                 |                     | ■   | 8               | ■    | 256                |
| LB 9124 A    | ■                    |                           |                            |                      |                                 | 1 ... 8<br>9 ... 16 |   | 2 x 8           | ■    | 256                |
| LB 9125 A    | ■                    |                           |                            |                      |                                 | 9 ... 16            |   | 8               | ■    | 256                |
| LB 9126 A    |                      | ■                         |                            |                      |                                 | 9 ... 16            |   | 8               | ■    | 256                |
| LB 9127 A    |                      |                           | ■                          |                      |                                 | 9 ... 16            |   | 8               | ■    | 256                |



FB-System

Digital Inputs

Digital Outputs

Analog Inputs

Analog Outputs

Bus Couplers

Power Supplies

Accessories

Field Units (Enclosures)

| Model Number          | Type       |                      | max. Number of Slots | Material        |                 | Fieldbus Type |                |            |               |                        | Mounting in Zone 1 and Zone 21 | Page |
|-----------------------|------------|----------------------|----------------------|-----------------|-----------------|---------------|----------------|------------|---------------|------------------------|--------------------------------|------|
|                       | Field Unit | Redundant Field Unit |                      | Stainless Steel | Polyester (GRP) | PROFIBUS DP   | PROFIBUS DP V1 | MODBUS RTU | MODBUS TCP/IP | FOUNDATION Fieldbus H1 |                                |      |
| FB 9210-PB0-0-0-0-0-F | ■          |                      | 5                    |                 | ■               |               |                |            |               |                        | ■                              | 258  |
| FB 9210-PB0-0-0-0-0-0 | ■          |                      | 10                   |                 | ■               | ■             | ■              | ■          |               |                        | ■                              | 259  |
| FB 9224-PG0-0-0-0-0-0 | ■          |                      | 24                   |                 | ■               | ■             | ■              | ■          |               |                        | ■                              | 260  |
| FB 9224-PH0-0-0-0-0-0 | ■          |                      | 24                   |                 | ■               | ■             | ■              | ■          |               |                        | ■                              | 261  |
| FB 9248-PG0-0-0-0-0-0 | ■          |                      | 48                   |                 | ■               | ■             | ■              | ■          |               |                        | ■                              | 262  |
| FB 9248-S70-0-0-0-0-0 | ■          |                      | 48                   | ■               |                 | ■             | ■              | ■          |               |                        | ■                              | 263  |
| FB 9249-PG0-0-0-0-0-0 |            | ■                    | 48                   |                 | ■               | ■             | ■              | ■          |               |                        | ■                              | 264  |
| FB 9249-S80-0-0-0-0-0 |            | ■                    | 48                   | ■               |                 | ■             | ■              | ■          |               |                        | ■                              | 265  |

Further Accessories

| Model Number | Description                             | Page |
|--------------|---|------|
| KF-CP        | Coding pins, packaging unit 20 x 6, red | 257  |
| F-NR-Ex1     | NAMUR Resistance Network                | 257  |
| FB 927*-300  | Extension cable, 3 m                    | 257  |
| FB 9283-300  | Extension cable, 3 m                    | 257  |

- FB-System
- Digital Inputs
- Digital Outputs
- Analog Inputs
- Analog Outputs
- Bus Couplers
- Power Supplies
- Accessories

| Technical data  |  |
|---|--|
| <b>Supply</b>   |  |
| Connection  | backplane bus  |
| <b>Ambient conditions</b>                               |  |
| Ambient temperature                                     | -20 ... 60 °C (-4 ... 140 °F)  |
| Storage temperature                                     | -25 ... 85 °C (-13 ... 185 °F)   |
| Relative humidity                                       | 95 % non-condensing  |
| Shock resistance  | shock type I, shock duration 11 ms, shock amplitude 50 m/s <sup>2</sup> , number of shock directions 6, number of shocks per direction 100           |
| Vibration resistance                                    | frequency range 5 ... 500 Hz, amplitude 5 ... 13.2 Hz ± 1.5 mm, 13.2 ... 100 Hz 1g, sweep rate 1 octave/min, duration 10 sweeps 5 Hz - 100 Hz - 5 Hz |
| Damaging gas  | for plugs: 21 days in 25 ppm SO <sub>2</sub> , at 25 °C and 75 % rel. humidity, device G3  |
| <b>Mechanical specifications</b>                        |  |
| Protection degree                                       | IP20 (module), a separate housing is required acc. to the system description   |
| Mass  | approx. 350 g  |
| Dimensions  | 28 x 107 x 132 mm (1.1 x 4.2 x 5.2 in)   |
| <b>Data for application in connection with Ex-areas</b> |  |
| EC-Type Examination Certificate                         | PTB 97 ATEX 1074 U, PTB 97 ATEX 1075 (system)  |
| Group, category, type of protection                     | ⊕ II 2 G Ex d IIC  |
| <b>International approvals</b>                          |  |
| IECEx approval  | pending  |

**Features**

- Terminates bus, service bus, or both depending on model
- Installation in suitable enclosures in Zone 1 and Zone 21
- Module can be exchanged under voltage in Zone 1 (hot swap; be aware bus operation may be affected)

**Function**

The device acts as a bus termination resistor to ensure signals are not reflected at the end of the line.  
It must be used in each last station of a bus line.

**Diagrams**

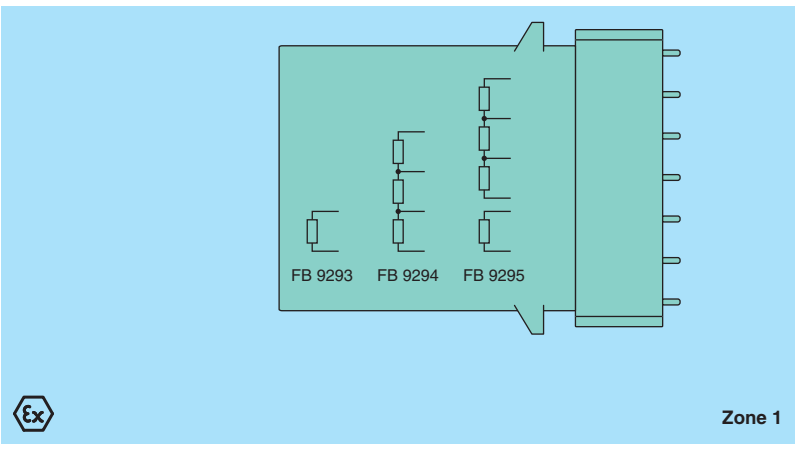

Front view

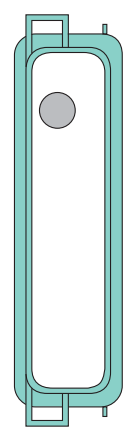

Edition 912907 (US) / 220718 (EU) 06/2011



**Terminal blocks**

**Terminal blocks, 6-pole, blue**

**LB 9107 A**  
with screw terminals  
6-pole, labeled 1 ... 6

**LB 9107 P**  
with wire clamp terminals  
6-pole, labeled 1 ... 6

**LB 9108 A**  
Cover for terminal block with screw terminals

**LB 9112 A**  
Cold junction module  
6-pole, labeled 1 ... 6

**LB 9117 A**  
with front screw terminals  
6-pole, labeled 1 ... 6

**Terminal blocks, 8-pole, blue**

**LB 9113 A**  
with screw terminals  
8-pole, labeled 1 ... 8

**LB 9115 A**  
with wire clamp terminals  
8-pole, labeled 1 ... 8

**LB 9116 A**  
with wire clamp terminals  
2 x 8-pole, labeled 1 ... 8 and 9 ... 16

**LB 9118 A**  
with front screw terminals  
8-pole, labeled 1 ... 8

**LB 9119 A**  
with front screw terminals  
2 x 8-pole, labeled 1 ... 8 and 9 ... 16

**LB 9120 A**  
Cover for terminal block with screw terminals

**LB 9124 A**  
with screw terminals  
2 x 8-pole, labeled 1 ... 8 and 9 ... 16

**LB 9125 A**  
with screw terminals labeled 9 ... 16

**LB 9126 A**  
with wire clamp terminals labeled 9 ... 16

**LB 9127 A**  
with front screw terminals labeled 9 ... 16

**Terminal blocks with screw terminals**

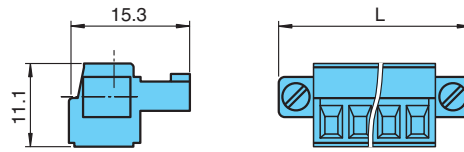

**Technical data**

|                                  |  |
|----------------------------------|--|
| <b>Mechanical specifications</b> | suitable for hood cover (below)          |
| <b>Dimensions</b>                | 6-pole: L = 33.3 mm, 8-pole: L = 40.9 mm |

**Terminal blocks with wire clamp terminals**

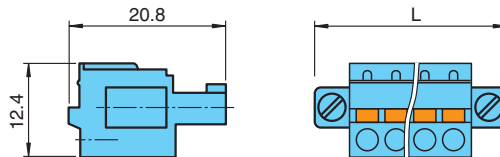

**Technical data**

|                                  |  |
|----------------------------------|--|
| <b>Mechanical specifications</b> |  |
| <b>Dimensions</b>                | 6-pole: L = 33.3 mm, 8-pole: L = 40.9 mm |

**Terminal blocks with front screw terminals**

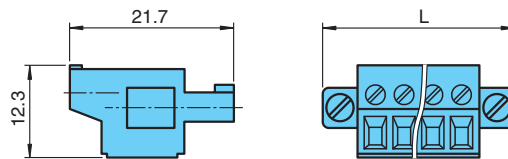

**Technical data**

|                                  |  |
|----------------------------------|--|
| <b>Mechanical specifications</b> |  |
| <b>Dimensions</b>                | 6-pole: L = 33.3 mm, 8-pole: L = 40.9 mm |

**Cover for terminal blocks with screw terminals**

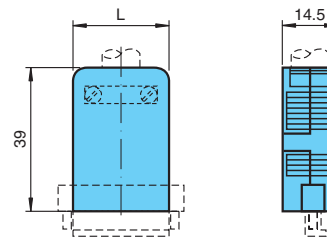

**Note:**

Only to be used with screw fixing connectors. Connectors with covers require enclosures to be at least 300 mm deep.

**Technical data**

|                                  |  |
|----------------------------------|--|
| <b>Mechanical specifications</b> |  |
| <b>Dimensions</b>                | 6-pole: L = 19.1 mm, 8-pole: L = 26.7 mm |

## Further Accessories

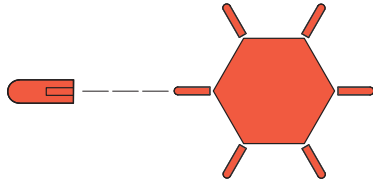

## Technical data

## Mechanical specifications

|            |                                       |
|------------|---------------------------------------|
| Material   | red insulating material               |
| Mass       | approx. 1 g per coding pin            |
| Dimensions | 0.5 x 2 x 8 mm (0.02 x 0.08 x 0.3 in) |

## Coding Pins

## KF-CP

## Features

- Coding of LB/FB-System terminal blocks
- Packaging unit: 20 x 6 coding pins

## Function

The terminals can be coded with a coding pin by inserting the red tab into a particular slot of the terminal block.

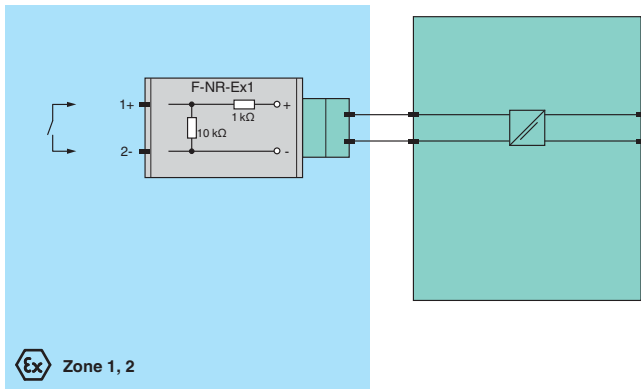

Ex Zone 1, 2

## Technical data

## Supply

Rated voltage max. 20 V DC

## Ambient conditions

Ambient temperature -20 ... 60 °C (-4 ... 140 °F)

## Mechanical specifications

|                   |  |
|-------------------|--|
| Protection degree | IP20   |
| Connection        | screw terminals, wire cross section: $\leq 1.5 \text{ mm}^2$ |
| Mass              | approx. 20 g   |
| Dimensions        | $\text{Ø}15.5 \times 35 \text{ mm}$ (0.61 x 1.38 in)         |

## NAMUR Resistor Network

## F-NR-Ex1

## Features

- 1-channel
- Dry contact input
- For line fault detection (LFD)

## Function

The NAMUR Resistor Network is used to monitor lead breakage and short circuit detection in switch amplifier circuits controlled by mechanical contacts. The component is installed directly to the control contact or inside its terminal box. The component can be used with all switch amplifiers featuring line fault detection.

For redundant unit – base unit (3 m)

For redundant unit – extension unit (3 m)

For base unit – extension unit (3 m)

For communication interface to redundant communication interface (3 m)

(Extension cables are included in the delivery of FB 9225, FB 9248, FB 9249)

## Extension Cables

FB 9271-300

FB 9273-300

FB 9272-300

FB 9283-300

FB-System  
Digital Inputs  
Digital Outputs  
Analog Inputs  
Analog Outputs  
Bus Couplers  
Power Supplies  
Accessories

**Features**

- Max. 5 slots for I/O modules
- Installation in Zone 1 and Zone 21
- Impact resistance enclosure, IP66/NEMA 4x
- For FOUNDATION fieldbus H1
- Packaged certified solution
- Standard enclosure for FB-System

**Function**

This field unit is designed to meet the requirements of the most demanding hazardous area and industrial environmental applications.

Glass-fiber reinforced polyester provides high corrosion resistance for both onshore and offshore installations. Electrostatic charge is avoided by suitable surface resistance.

It is equipped with plug-in slots for 5 dual width I/O modules.

Any I/O module can be inserted into any slot, enabling a mixture of I/O types in one field unit.

**Technical data**

**Mechanical specifications**

|   |  |
|---|--|
| Dimensions  | (W x H x D) 544 x 271 x 210 mm (21.4 x 10.7 x 8.3 in)  |
| Protection degree   | IP66, NEMA 4x  |
| <b>Material</b>   |  |
| Housing   | polyester, impact resistant, glass fiber reinforced  |
| Surface   | black molded finish (RAL 9005)   |
| Cable gland   | Polyamide (PA)   |
| Mass  | approx. 10 kg, without modules   |
| Enclosure cover   | detachable cover with retaining screws   |
| Mounting  | clearance holes Ø6.5 mm  |
| <b>Ambient conditions</b>                                       |  |
| Ambient temperature   | -20 ... 55 °C (-4 ... 131 °F) at T4<br>-20 ... 40 °C (-4 ... 104 °F) at T6   |
| Storage temperature   | -40 ... 70 °C (-40 ... 158 °F)   |
| <b>Slots</b>  |  |
| Bus coupler   | 1  |
| Supply  | 1  |
| I/O modules (dual width)  | max. 5   |
| <b>Supply</b>   |  |
| Connection  | screw terminals, max. 10 mm <sup>2</sup>   |
| Rated voltage   | 24 V DC/115 V AC/230 V AC, depends on power supply   |
| Redundancy  | no   |
| <b>Fieldbus interface</b>                                       |  |
| Connection  | wire clamp terminals, max. 2.5 mm <sup>2</sup>   |
| Redundancy  | no   |
| <b>Electrical specifications</b>                                |  |
| Permissible power   | 34 W (DC/AC)   |
| <b>Data for application in connection with Ex-areas</b>         |  |
| EC-Type Examination Certificate                                 | PTB 97 ATEX 1075   |
| Group, category, type of protection, temperature classification | ⊗ II 2(1)G EEx dem [ia] IIC T4/T6<br>⊗ II 2(1)D IP66 T80°C<br>⊗ II (1)D [Ex ia] IIIC<br>⊗ II (2)D [Ex ib] IIIC           |
| Directive conformity  |  |
| Directive 94/9/EC   | EN 60079-0:2009, EN 60079-1:2007, EN 60079-7:2003, EN 60079-18:2004, EN 60079-11:2007, EN 61010-1:2001, EN 61241-11:2006 |
| <b>International approvals</b>                                  |  |
| INMETRO   | 2008EC02CP011  |

**Diagrams**

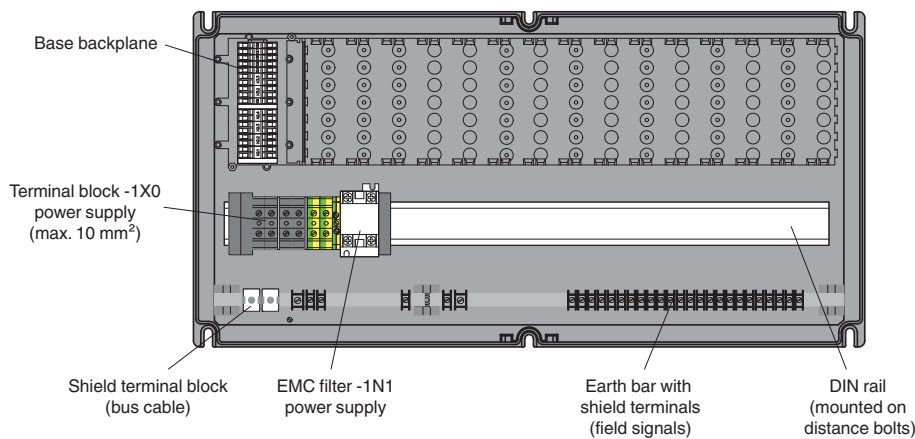

Drawn without cover and cable glands!

## Technical data

|   |  |
|---|--|
| <b>Mechanical specifications</b>                                |  |
| Dimensions  | (W x H x D) 544 x 271 x 210 mm (21.4 x 10.7 x 8.3 in)  |
| Protection degree   | IP66, NEMA 4x  |
| <b>Material</b>   |  |
| Housing   | polyester, impact resistant, glass fiber reinforced  |
| Surface   | black molded finish (RAL 9005)   |
| Cable gland   | Polyamide (PA)   |
| Mass  | approx. 10 kg, without modules   |
| Enclosure cover   | detachable cover with retaining screws   |
| Mounting  | clearance holes Ø6.5 mm  |
| <b>Ambient conditions</b>                                       |  |
| Ambient temperature   | -20 ... 55 °C (-4 ... 131 °F) at T4<br>-20 ... 40 °C (-4 ... 104 °F) at T6   |
| Storage temperature   | -40 ... 70 °C (-40 ... 158 °F)   |
| <b>Slots</b>  |  |
| Bus coupler   | 1  |
| Supply  | 1  |
| I/O modules (single width)                                      | max. 10  |
| I/O modules (dual width)  | max. 5   |
| <b>Supply</b>   |  |
| Connection  | screw terminals, max. 10 mm <sup>2</sup>   |
| Rated voltage   | 24 V DC/115 V AC/230 V AC, depends on power supply   |
| Redundancy  | no   |
| <b>Fieldbus interface</b>                                       |  |
| Connection  | wire clamp terminals, max. 2.5 mm <sup>2</sup>   |
| Redundancy  | no   |
| <b>Electrical specifications</b>                                |  |
| Permissible power   | 34 W (DC/AC)   |
| <b>Data for application in connection with Ex-areas</b>         |  |
| EC-Type Examination Certificate                                 | PTB 97 ATEX 1075   |
| Group, category, type of protection, temperature classification | ⊕ II 2(1)G EEx dem [ia] IIC T4/T6<br>⊕ II 2(1)D IP66 T80°C<br>⊕ II (1)D [Ex ia] IIIC<br>⊕ II (2)D [Ex ib] IIIC           |
| Directive conformity  |  |
| Directive 94/9/EC   | EN 60079-0:2009, EN 60079-1:2007, EN 60079-7:2003, EN 60079-18:2004, EN 60079-11:2007, EN 61010-1:2001, EN 61241-11:2006 |
| <b>International approvals</b>                                  |  |
| INMETRO   | 2008EC02CP011  |

## Features

- Max. 10 slots for I/O modules
- Installation in Zone 1 and Zone 21
- Impact resistance enclosure, IP66/NEMA 4x
- For PROFIBUS DP, PROFIBUS DP V1 and MODBUS RTU
- Packaged certified solution
- Standard enclosure for FB-System

## Function

This field unit is designed to meet the requirements of the most demanding hazardous area and industrial environmental applications.

Glass-fiber reinforced polyester provides high corrosion resistance for both onshore and offshore installations. Electrostatic charge is avoided by suitable surface resistance.

It is equipped with plug-in slots for 5 dual width I/O modules or 10 single width I/O modules.

Any I/O module can be inserted into any slot, enabling a mixture of I/O types in one field unit.

## Diagrams

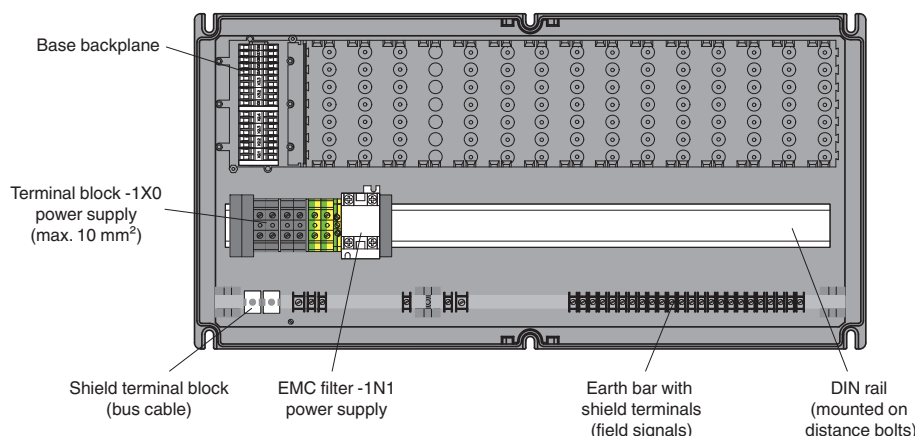

Drawn without cover and cable glands!

FB-System  
Digital Inputs  
Digital Outputs  
Analog Inputs  
Analog Outputs  
Bus Couplers  
Power Supplies  
Accessories

**Features**

- Max. 24 slots for I/O modules
- Installation in Zone 1 and Zone 21
- Impact resistance enclosure, IP66/NEMA 4x
- For PROFIBUS DP, PROFIBUS DP V1 and MODBUS RTU
- Packaged certified solution
- Standard enclosure for FB-System

**Function**

This field unit is designed to meet the requirements of the most demanding hazardous area and industrial environmental applications.

Glass-fiber reinforced polyester provides high corrosion resistance for both onshore and offshore installations. Electrostatic charge is avoided by suitable surface resistance.

It is equipped with plug-in slots for 12 dual width I/O modules or 24 single width I/O modules.

Any I/O module can be inserted into any slot, enabling a mixture of I/O types in one field unit.

**Technical data**

**Mechanical specifications**

|                   |   |
|-------------------|---|
| Dimensions        | (W x H x D) 544 x 407 x 210 mm (21.4 x 16 x 8.3 in) |
| Protection degree | IP66, NEMA 4x                                       |
| Material          |   |
| Housing           | polyester, impact resistant, glass fiber reinforced |
| Surface           | black molded finish (RAL 9005)                      |
| Cable gland       | Polyamide (PA)                                      |
| Mass              | approx. 14 kg, without modules                      |
| Enclosure cover   | detachable cover with retaining screws              |
| Mounting          | clearance holes Ø6.5 mm                             |

**Ambient conditions**

|                     |  |
|---------------------|--|
| Ambient temperature | -20 ... 55 °C (-4 ... 131 °F) at T4<br>-20 ... 40 °C (-4 ... 104 °F) at T6 |
| Storage temperature | -40 ... 70 °C (-40 ... 158 °F)   |

**Slots**

|                            |         |
|----------------------------|---------|
| Bus coupler                | 1       |
| Supply                     | 1       |
| I/O modules (single width) | max. 24 |
| I/O modules (dual width)   | max. 12 |

**Supply**

|               |  |
|---------------|--|
| Connection    | screw terminals, max. 10 mm <sup>2</sup>           |
| Rated voltage | 24 V DC/115 V AC/230 V AC, depends on power supply |
| Redundancy    | no   |

**Fieldbus interface**

|            |  |
|------------|--|
| Connection | wire clamp terminals, max. 2.5 mm <sup>2</sup> |
| Redundancy | no   |

**Electrical specifications**

|                   |              |
|-------------------|--------------|
| Permissible power | 43 W (DC/AC) |
|-------------------|--------------|

**Data for application in connection with Ex-areas**

|   |  |
|---|--|
| EC-Type Examination Certificate                                 | PTB 97 ATEX 1075   |
| Group, category, type of protection, temperature classification | ⊗ II 2(1)G EEx dem [ia] IIC T4/T6<br>⊗ II 2(1)D IP66 T80°C<br>⊗ II (1)D [Ex ia] IIIC<br>⊗ II (2)D [Ex ib] IIIC |

|                      |  |
|----------------------|--|
| Directive conformity |  |
| Directive 94/9/EC    | EN 60079-0:2009, EN 60079-1:2007, EN 60079-7:2003, EN 60079-18:2004, EN 60079-11:2007, EN 61010-1:2001, EN 61241-11:2006 |

**International approvals**

|         |               |
|---------|---------------|
| INMETRO | 2008EC02CP011 |
|---------|---------------|

**Diagrams**

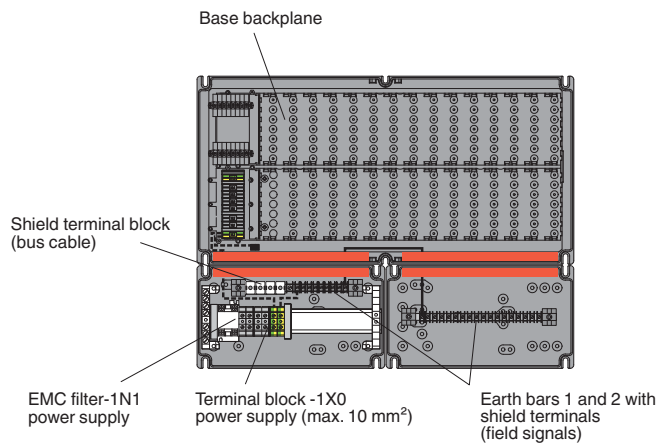

Drawn without cover and cable glands!



**Technical data**

**Mechanical specifications**

|                   |   |
|-------------------|---|
| Dimensions        | (W x H x D) 544 x 544 x 210 mm (21.4 x 21.4 x 8.3 in) |
| Protection degree | IP66, NEMA 4x   |
| <b>Material</b>   |   |
| Housing           | polyester, impact resistant, glass fiber reinforced   |
| Surface           | black molded finish (RAL 9005)                        |
| Cable gland       | Polyamide (PA)  |
| Mass              | approx. 15 kg, without modules                        |
| Enclosure cover   | detachable cover with retaining screws                |
| Mounting          | clearance holes Ø6.5 mm                               |

**Ambient conditions**

|                     |  |
|---------------------|--|
| Ambient temperature | -20 ... 55 °C (-4 ... 131 °F) at T4<br>-20 ... 40 °C (-4 ... 104 °F) at T6 |
| Storage temperature | -40 ... 70 °C (-40 ... 158 °F)   |

**Slots**

|                            |         |
|----------------------------|---------|
| Bus coupler                | 1       |
| Supply                     | 1       |
| I/O modules (single width) | max. 24 |
| I/O modules (dual width)   | max. 12 |

**Supply**

|               |  |
|---------------|--|
| Connection    | screw terminals, max. 10 mm <sup>2</sup>           |
| Rated voltage | 24 V DC/115 V AC/230 V AC, depends on power supply |
| Redundancy    | no   |

**Fieldbus interface**

|            |  |
|------------|--|
| Connection | wire clamp terminals, max. 2.5 mm <sup>2</sup> |
| Redundancy | no   |

**Electrical specifications**

|                   |              |
|-------------------|--------------|
| Permissible power | 53 W (DC/AC) |
|-------------------|--------------|

**Data for application in connection with Ex-areas**

|   |  |
|---|--|
| EC-Type Examination Certificate                                 | PTB 97 ATEX 1075   |
| Group, category, type of protection, temperature classification | ⊕ II 2(1)G EEx dem [ia] IIC T4/T6<br>⊕ II 2(1)D IP66 T80°C<br>⊕ II (1)D [Ex ia] IIIC<br>⊕ II (2)D [Ex ib] IIIC |

|                      |  |
|----------------------|--|
| Directive conformity |  |
| Directive 94/9/EC    | EN 60079-0:2009, EN 60079-1:2007, EN 60079-7:2003, EN 60079-18:2004, EN 60079-11:2007, EN 61010-1:2001, EN 61241-11:2006 |

**International approvals**

|         |               |
|---------|---------------|
| INMETRO | 2008EC02CP011 |
|---------|---------------|

**Features**

- Max. 24 slots for I/O modules
- Installation in Zone 1 and Zone 21
- Impact resistance enclosure, IP66/NEMA 4x
- For PROFIBUS DP, PROFIBUS DP V1 and MODBUS RTU
- Packaged certified solution
- Standard enclosure for FB-System

**Function**

This field unit is designed to meet the requirements of the most demanding hazardous area and industrial environmental applications. Glass-fiber reinforced polyester provides high corrosion resistance for both onshore and offshore installations. Electrostatic charge is avoided by suitable surface resistance. It is equipped with plug-in slots for 12 dual width I/O modules or 24 single width I/O modules. Any I/O module can be inserted into any slot, enabling a mixture of I/O types in one field unit.

**Diagrams**

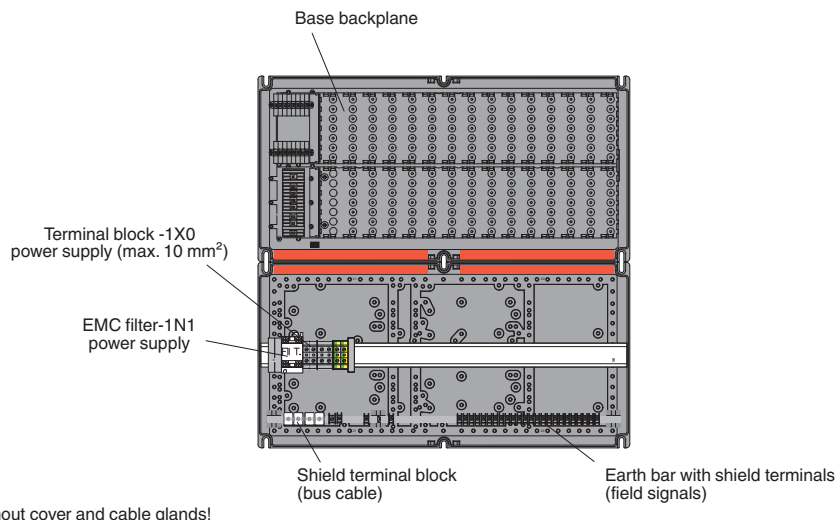

FB-System  
Digital Inputs  
Digital Outputs  
Analog Inputs  
Analog Outputs  
Bus Couplers  
Power Supplies  
Accessories

**Features**

- Max. 48 slots for I/O modules
- Installation in Zone 1 and Zone 21
- Impact resistance enclosure, IP66/NEMA 4x
- Consisting of base unit and extension unit
- For PROFIBUS DP, PROFIBUS DP V1 and MODBUS RTU
- Packaged certified solution
- Standard enclosure for FB-System

**Function**

This field unit is designed to meet the requirements of the most demanding hazardous area and industrial environmental applications. Glass-fiber reinforced polyester provides high corrosion resistance for both onshore and offshore installations. Electrostatic charge is avoided by suitable surface resistance. It is equipped with plug-in slots for 24 dual width I/O modules or 48 single width I/O modules. Any I/O module can be inserted into any slot, enabling a mixture of I/O types in one field unit.

**Technical data**

| Mechanical specifications                                       |  |
|---|--|
| Dimensions  | (W x H x D)<br>base unit: 544 x 407 x 210 mm (21.4 x 16 x 8.3 in)<br>extension unit: 544 x 407 x 210 mm (21.4 x 16 x 8.3 in) |
| Protection degree   | IP66, NEMA 4x  |
| Material  |  |
| Housing   | polyester, impact resistant, glass fiber reinforced  |
| Mass  | approx. 2 x 14 kg  |
| Enclosure cover   | detachable cover with retaining screws   |
| Mounting  | clearance holes Ø6.5 mm  |
| Ambient conditions  |  |
| Ambient temperature   | -20 ... 55 °C (-4 ... 131 °F) at T4<br>-20 ... 40 °C (-4 ... 104 °F) at T6   |
| Storage temperature   | -40 ... 70 °C (-40 ... 158 °F)   |
| Slots   |  |
| Bus coupler   | 1  |
| Supply  | 2  |
| I/O modules (single width)                                      | max. 48  |
| I/O modules (dual width)  | max. 24  |
| Supply  |  |
| Connection  | screw terminals  |
| Rated voltage   | 24 V DC/115 V AC/230 V AC, depends on power supply   |
| Redundancy  | no   |
| Fieldbus interface  |  |
| Connection  | wire clamp terminals, max. 2.5 mm <sup>2</sup>   |
| Redundancy  | no   |
| Electrical specifications                                       |  |
| Permissible power   | 43 W (DC/AC), each for base and extension unit   |
| Data for application in connection with Ex-areas                |  |
| EC-Type Examination Certificate                                 | PTB 97 ATEX 1075   |
| Group, category, type of protection, temperature classification | ⊕ II 2(1)G EEx dem [ia] IIC T4/T6<br>⊕ II 2(1)D IP66 T80°C<br>⊕ II (1)D [Ex ia] IIC<br>⊕ II (2)D [Ex ib] IIC                 |
| Directive conformity  |  |
| Directive 94/9/EC   | EN 60079-0:2009, EN 60079-1:2007, EN 60079-7:2003, EN 60079-18:2004, EN 60079-11:2007, EN 61010-1:2001, EN 61241-11:2006     |
| International approvals   |  |
| INMETRO   | 2008EC02CP011  |

**Diagrams**

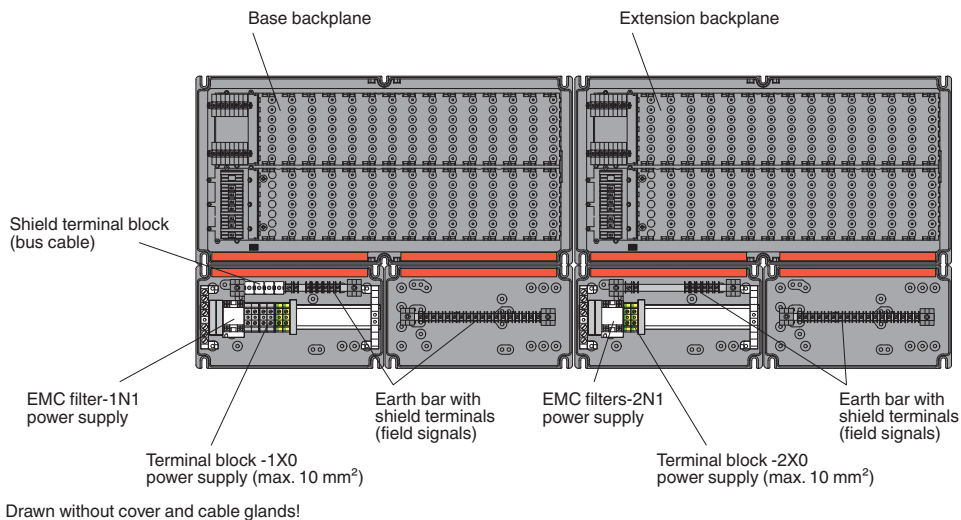

Edition 912907 (US) / 220718 (EU) 06/2011

**Technical data**

**Mechanical specifications**

|                   |  |
|-------------------|--|
| Dimensions        | (W x H x D) 800 x 800 x 300 mm (31.5 x 31.5 x 11.8 in) |
| Protection degree | IP66, NEMA 4x  |
| <b>Material</b>   |  |
| Housing           | Stainless steel 1.4404/AISI 316L                       |
| Mass              | approx. 50 kg, without modules                         |
| Enclosure cover   | hinged door with cam lock and double-bit insert        |
| Mounting          | clearance holes Ø11 mm                                 |
| Grounding         | grounding bolt M10, brass                              |

**Ambient conditions**

|                     |  |
|---------------------|--|
| Ambient temperature | -20 ... 55 °C (-4 ... 131 °F) at T4<br>-20 ... 40 °C (-4 ... 104 °F) at T6 |
| Storage temperature | -40 ... 70 °C (-40 ... 158 °F)   |

**Slots**

|                            |         |
|----------------------------|---------|
| Bus coupler                | 1       |
| Bus termination            | 1       |
| Supply                     | 2       |
| I/O modules (single width) | max. 48 |
| I/O modules (dual width)   | max. 24 |

**Supply**

|               |  |
|---------------|--|
| Connection    | screw terminals, max. 10 mm <sup>2</sup>           |
| Rated voltage | 24 V DC/115 V AC/230 V AC, depends on power supply |
| Redundancy    | no   |

**Fieldbus interface**

|            |  |
|------------|--|
| Connection | wire clamp terminals, max. 2.5 mm <sup>2</sup> |
| Redundancy | no   |

**Electrical specifications**

|                   |   |
|-------------------|---|
| Permissible power | wall mounting: 176 W (at 40 °C (104 °F)),<br>88 W (at 50 °C (122 °F)) |
|-------------------|---|

**Data for application in connection with Ex-areas**

|   |  |
|---|--|
| EC-Type Examination Certificate                                 | PTB 97 ATEX 1075   |
| Group, category, type of protection, temperature classification | ⊗ II 2(1)G EEx dem [ia] IIC T4/T6<br>⊗ II 2(1)D IP66 T80°C<br>⊗ II (1)D [Ex ia] IIC<br>⊗ II (2)D [Ex ib] IIC             |
| Directive conformity  |  |
| Directive 94/9/EC   | EN 60079-0:2009, EN 60079-1:2007, EN 60079-7:2003, EN 60079-18:2004, EN 60079-11:2007, EN 61010-1:2001, EN 61241-11:2006 |

**International approvals**

|         |               |
|---------|---------------|
| INMETRO | 2008EC02CP011 |
|---------|---------------|

**Features**

- Max. 48 slots for I/O modules
- Installation in Zone 1 and Zone 21
- Electropolished enclosure, IP66/NEMA 4x
- For PROFIBUS DP, PROFIBUS DP V1 and MODBUS RTU
- Packaged certified solution
- Standard enclosure for FB-System

**Function**

This field unit is designed to meet the requirements of the most demanding hazardous area and industrial environmental applications. Electropolished stainless steel 316L provides high corrosion resistance for both onshore and offshore installations. The one piece seal is protected from standing water damage by the box's integral rain channel. It is equipped with plug-in slots for 24 dual width I/O modules or 48 single width I/O modules. Any I/O module can be inserted into any slot, enabling a mixture of I/O types in one field unit.

**Diagrams**

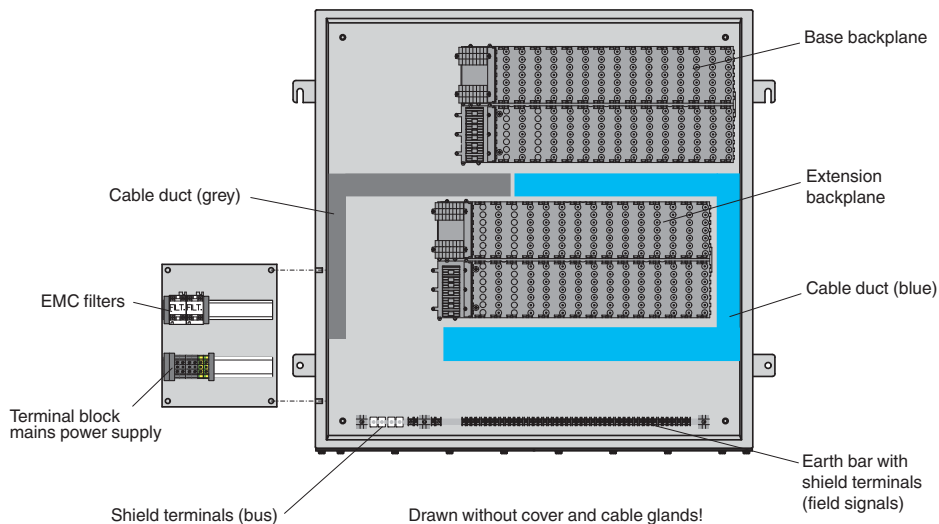

Edition 912907 (US) / 220718 (EU) 06/2011

Subject to modifications without notice

Pepperl+Fuchs Group  
www.pepperl-fuchs.com

USA: +1 330 486 0002  
pa-info@us.pepperl-fuchs.com

Germany: +49 621 776 2222  
pa-info@de.pepperl-fuchs.com

Copyright Pepperl+Fuchs  
Singapore: +65 6779 9091  
pa-info@sg.pepperl-fuchs.com



FB-System  
Digital Inputs  
Digital Outputs  
Analog Inputs  
Analog Outputs  
Bus Couplers  
Power Supplies  
Accessories

**Features**

- Max. 48 slots for I/O modules
- Installation in Zone 1 and Zone 21
- Impact resistance enclosure, IP66/NEMA 4x
- Consisting of redundancy unit, base unit, and extension unit
- Redundancy (field bus and power supply)
- For PROFIBUS DP, PROFIBUS DP V1 and MODBUS RTU
- Packaged certified solution
- Standard enclosure for FB-System

**Function**

This field unit is designed to meet the requirements of the most demanding hazardous area and industrial environmental applications.

Glass-fiber reinforced polyester provides high corrosion resistance for both onshore and offshore installations. Electrostatic charge is avoided by suitable surface resistance.

It is equipped with plug-in slots for 24 dual width I/O modules or 48 single width I/O modules.

Any I/O module can be inserted into any slot, enabling a mixture of I/O types in one field unit.

The fieldbus and power supply are equipped with redundant connections.

**Technical data**

|   |   |
|---|---|
| <b>Mechanical specifications</b>                                |   |
| Dimensions  | (W x H x D) redundancy unit: 271 x 407 x 210 mm (10.7 x 16 x 8.3 in)<br>base unit: 544 x 407 x 210 mm (21.4 x 16 x 8.3 in)<br>extension unit: 544 x 407 x 210 mm (21.4 x 16 x 8.3 in) |
| Protection degree   | IP66, NEMA 4x   |
| <b>Material</b>   |   |
| Housing   | polyester, impact resistant, glass fiber reinforced   |
| Mass  | approx. 2 x 14 kg + 1 x 6 kg, without modules   |
| Enclosure cover   | detachable cover with retaining screws  |
| Mounting  | clearance holes Ø6.5 mm   |
| Grounding   | grounding bolt M6, Stainless steel  |
| <b>Ambient conditions</b>                                       |   |
| Ambient temperature   | -20 ... 55 °C (-4 ... 131 °F) at T4<br>-20 ... 40 °C (-4 ... 104 °F) at T6  |
| Storage temperature   | -40 ... 70 °C (-40 ... 158 °F)  |
| <b>Slots</b>  |   |
| Bus coupler   | 2   |
| Supply  | 4   |
| I/O modules (single width)                                      | max. 48   |
| I/O modules (dual width)  | max. 24   |
| <b>Supply</b>   |   |
| Connection  | screw terminals   |
| Rated voltage   | 24 V DC/115 V AC/230 V AC, depends on power supply  |
| Redundancy  | yes   |
| <b>Fieldbus interface</b>                                       |   |
| Connection  | wire clamp terminals, max. 2.5 mm <sup>2</sup>  |
| Redundancy  | yes   |
| <b>Electrical specifications</b>                                |   |
| Permissible power   | 43 W (DC/AC), each for base and extension unit  |
| <b>Data for application in connection with Ex-areas</b>         |   |
| EC-Type Examination Certificate                                 | PTB 97 ATEX 1075  |
| Group, category, type of protection, temperature classification | ⊗ II 2(1)G EEx dem [ia] IIC T4/T6<br>⊗ II 2(1)D IP66 T80°C<br>⊗ II (1)D [Ex ia] IIIC<br>⊗ II (2)D [Ex ib] IIIC  |
| <b>Directive conformity</b>                                     |   |
| Directive 94/9/EC   | EN 60079-0:2009, EN 60079-1:2007, EN 60079-7:2003, EN 60079-18:2004, EN 60079-11:2007, EN 61010-1:2001, EN 61241-11:2006  |
| <b>International approvals</b>                                  |   |
| INMETRO   | 2008EC02CP011   |

**Diagrams**

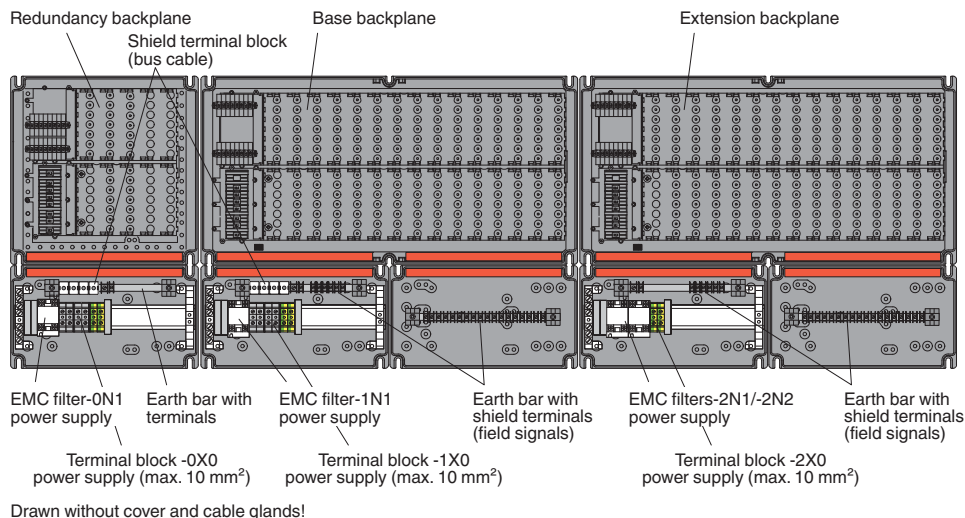

Drawn without cover and cable glands!

Edition 912907 (US) / 220718 (EU) 06/2011

**Technical data**

|   |  |
|---|--|
| <b>Mechanical specifications</b>                                |  |
| Dimensions  | (W x H x D) 800 x 1000 x 300 mm (31.5 x 39.4 x 11.8 in)  |
| Protection degree   | IP66, NEMA 4x  |
| <b>Material</b>   |  |
| Housing   | Stainless steel 1.4404/AISI 316L   |
| Mass  | approx. 75 kg, without modules   |
| Enclosure cover   | hinged door with cam lock and double-bit insert  |
| Mounting  | clearance holes Ø11 mm   |
| Grounding   | grounding bolt M10, brass  |
| <b>Ambient conditions</b>                                       |  |
| Ambient temperature   | -20 ... 40 °C (-4 ... 104 °F) at T6<br>-20 ... 55 °C (-4 ... 131 °F) at T4   |
| Storage temperature   | -40 ... 70 °C (-40 ... 158 °F)   |
| <b>Slots</b>  |  |
| Bus coupler   | 2  |
| Bus termination   | 2  |
| Supply  | 4  |
| I/O modules (single width)                                      | max. 48  |
| I/O modules (dual width)  | max. 24  |
| <b>Supply</b>   |  |
| Connection  | screw terminals, max. 10 mm <sup>2</sup>   |
| Rated voltage   | 24 V DC/115 V AC/230 V AC, depends on power supply   |
| Redundancy  | yes  |
| <b>Fieldbus interface</b>                                       |  |
| Connection  | wire clamp terminals, max. 2.5 mm <sup>2</sup>   |
| Redundancy  | yes  |
| <b>Electrical specifications</b>                                |  |
| Permissible power   | wall mounting: 206 W (at 40 °C (104 °F)),<br>103 W (at 50 °C (122 °F))   |
| <b>Data for application in connection with Ex-areas</b>         |  |
| EC-Type Examination Certificate                                 | PTB 97 ATEX 1075   |
| Group, category, type of protection, temperature classification | ⊗ II 2(1)G EEx dem [ia] IIC T4/T6<br>⊗ II 2(1)D IP66 T80°C<br>⊗ II (1)D [Ex ia] IIC<br>⊗ II (2)D [Ex ib] IIC             |
| Directive conformity  |  |
| Directive 94/9/EC   | EN 60079-0:2009, EN 60079-1:2007, EN 60079-7:2003, EN 60079-18:2004, EN 60079-11:2007, EN 61010-1:2001, EN 61241-11:2006 |
| <b>International approvals</b>                                  |  |
| INMETRO   | 2008EC02CP011  |

**Diagrams**

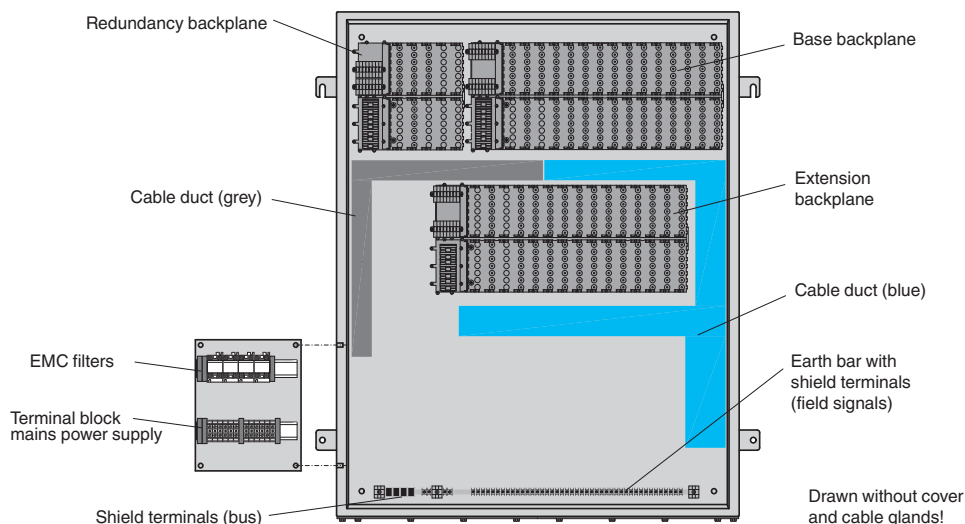

**Features**

- Max. 48 slots for I/O modules
- Installation in Zone 1 and Zone 21
- Electropolished enclosure, IP66/NEMA 4x
- Redundancy (field bus and power supply)
- For PROFIBUS DP, PROFIBUS DP V1 and MODBUS RTU
- Packaged certified solution
- Standard enclosure for FB-System

**Function**

This field unit is designed to meet the requirements of the most demanding hazardous area and industrial environmental applications.

Electropolished stainless steel 316L provides high corrosion resistance for both onshore and offshore installations. The one piece seal is protected from standing water damage by the box's integral rain channel.

It is equipped with plug-in slots for 24 dual width I/O modules or 48 single width I/O modules.

Any I/O module can be inserted into any slot, enabling a mixture of I/O types in one field unit.

The fieldbus and power supply are equipped with redundant connections.



FB-System

Digital Inputs

Digital Outputs

Analog Inputs

Analog Outputs

Bus Couplers

Power Supplies

Accessories

Edition 912907 (US) / 220718 (EU) 06/2011

Subject to modifications without notice

Pepperl+Fuchs Group  
www.pepperl-fuchs.com

USA: +1 330 486 0002  
pa-info@us.pepperl-fuchs.com

Germany: +49 621 776 2222  
pa-info@de.pepperl-fuchs.com

Copyright Pepperl+Fuchs  
Singapore: +65 6779 9091  
pa-info@sg.pepperl-fuchs.com



# FOUNDATION Fieldbus Modular I/O

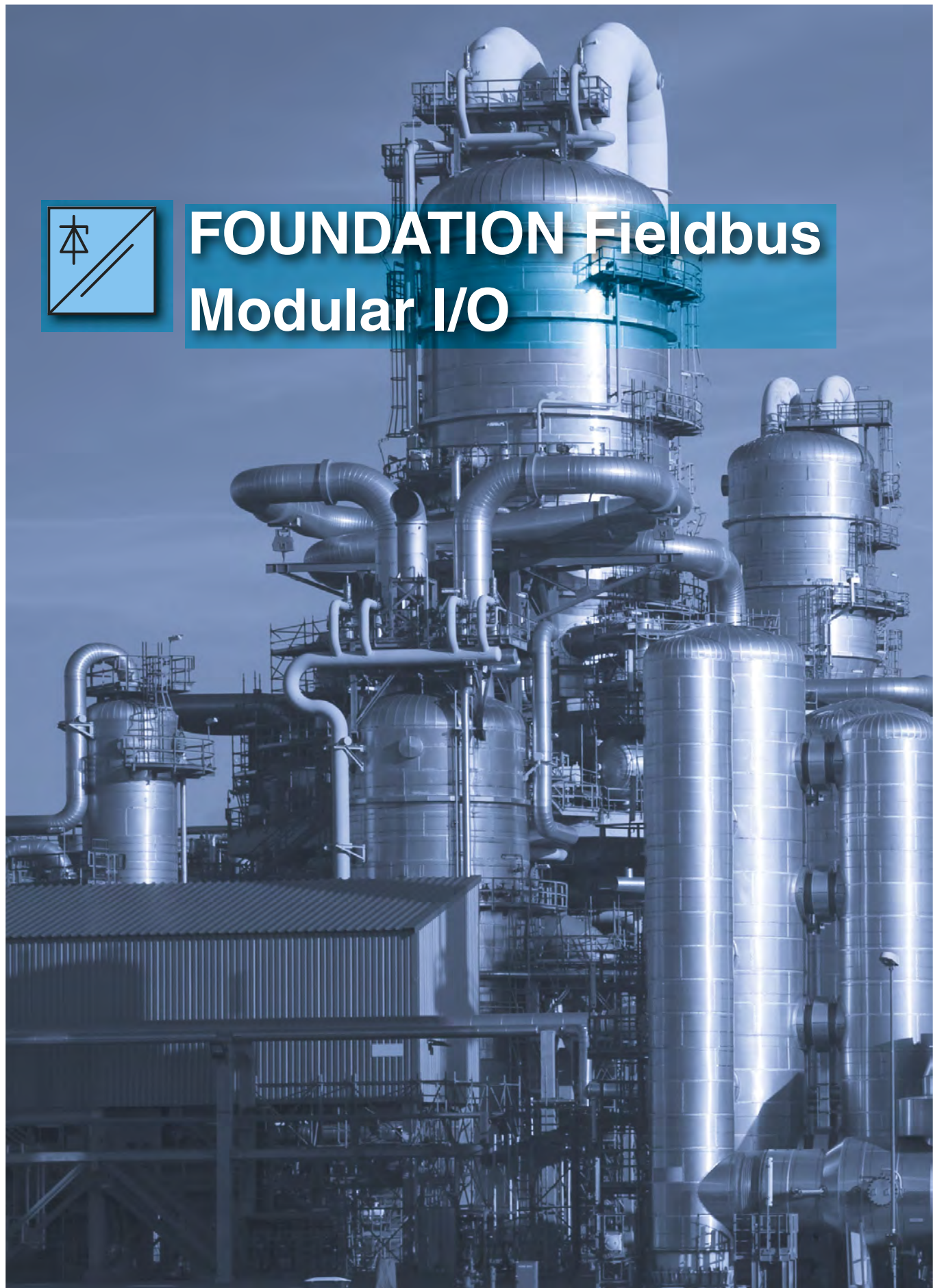

Edition 912907 (US) / 220718 (EU) 06/2011



## Modular Concept for FOUNDATION Fieldbus

LB and FB Remote I/O are important signal conditioning devices for interfacing sensors and signals from legacy field devices to the FOUNDATION Fieldbus Host of controllers or process control systems. For the first time there is now a modular concept to adapt digital and analog signals to the FOUNDATION Fieldbus. The plug-in modules are mounted on pre-fabricated plastic backplanes for installation in potentially explosive atmospheres in Zone 2 or Zone 22 for LB or Zone 1 and Zone 21 for FB.

The various IS I/O modules can be plugged in or removed during operation without the need for a hot work permit. Other advantages include the galvanic isolation and the amplification properties.

What is more, the wiring is reduced to that of a standard bus connection. The galvanic isolation provides a safe and reliable interface between the process and the bus. The amplification properties and the digital transmission ensure a high degree of measurement accuracy which is not influenced by variations in the auxiliary power supply.

LEDs indicate the status of the respective device. A green LED indicates the operating status, while a red LED indicates a fault, e. g. an open line or short circuit. The PLC or DCS can call upon this data via the bus.

### LB Modular I/O for Safe Areas or Zone 2, Zone 22, Div. 2

268



- 4 to 8 channels digital
- 4 channels analog
- Direct connection to the FOUNDATION Fieldbus Trunk
- Zone 2 or Div. 2 mounting possible
- Plug-in modules for analog and digital inputs and outputs
- Screw-in and plug-in cable connections directly on the module
- Optional wire clamp connectors
- Safe galvanic isolation
- LED status indication
- Low power consumption
- ATEX certification for Ex ia/ib
- International approvals

### FB Modular I/O for Zone 1, or Zone 21

268



- 4 to 8 channels digital
- 4 channels analog
- Direct connection to the FOUNDATION Fieldbus Trunk
- Zone 1 mounting possible
- Plug-in modules for analog and digital inputs and outputs
- Screw-in and plug-in cable connections directly on the module
- Optional wire clamp connectors
- Safe galvanic isolation
- LED status indication
- Low power consumption
- ATEX certification for Ex ia/ib
- International approvals

FF Modular I/O

Bus Couplers

Accessories

# Modular I/O

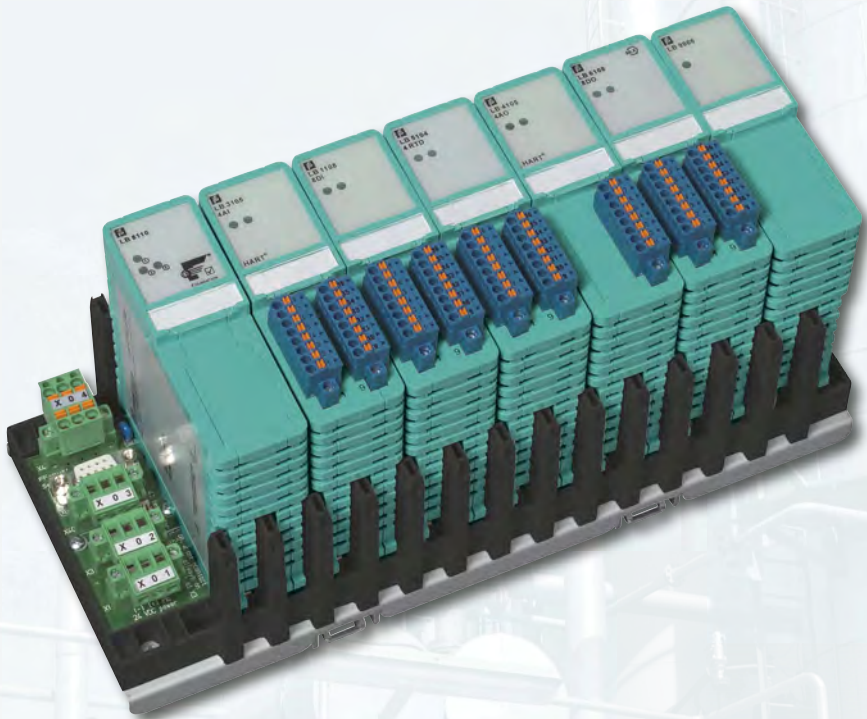



**System Description** ..... 270

**Bus Couplers**

**Selection Tables** ..... 275

**Product Data Sheets** ..... 276

**Accessories**

**Selection Tables** ..... 279

**Product Data Sheets** ..... 280



FF Modular I/O

Bus Couplers

Accessories

Edition 912907 (US) / 220718 (EU) 06/2011



## Introduction

Fieldbus systems are increasingly being used when new plants are built in the chemical, petrochemical, and pharmaceutical industries as well as in the oil and gas sector.

The associated intelligent field devices ensure the best possible transparency and flexibility. These technologies offer the user the opportunity to reduce instrumentation and maintenance costs during commissioning and during the plant life cycle.

Pepperl+Fuchs covers a wide variety of fieldbus products while the field devices themselves are supplied by many different manufacturers. Within these applications FOUNDATION fieldbus Modular I/O can be seen as a suitable extension to the existing FieldConnex range that Pepperl+Fuchs has on offer. While FieldConnex covers fieldbus power supplies, segment protectors, field barriers, and process interfaces to drive valves or measure temperature, the FF Modular I/O adapts all the traditional input and output signals to the fieldbus.

In this context the FF Modular I/O makes use of the same basic system building blocks such as power supplies and the high power trunk. The following chapters explain the most important principles that need to be observed. More details can be found in our Fieldbus Engineer's Guide.

Although most manufacturers now offer devices with direct Fieldbus connection there are still many signals which do not lend themselves to this approach. Either the signals consist of simple On/Off status information and it would be too costly to fit them with a FOUNDATION fieldbus interface individually, or the field device manufacturer only offers the classic 4 mA ... 20 mA control and instrumentation signal.

FOUNDATION fieldbus Modular I/O now fills this gap. It even offers advanced diagnostics where traditionally, the attention applied to the 4 mA ... 20 mA cable systems and instruments during the construction and commissioning phases would have involved manually operated test equipment or loop testers used by highly qualified engineers. Under "time pressure", loops may have been left unchecked or not fully assessed for less obvious (but tolerated) faults that could cause problems later down the line during operation.

In a way FOUNDATION fieldbus Modular I/O is not only an I/O device but it can also be seen as a piece of automatic test equipment, providing diagnostic information via the bus attached to every 4 mA ... 20 mA loop and operated continuously. This automatic test equipment is left in place to continue monitoring the health of each loop during the plant's operational life.

## FOUNDATION Fieldbus Modular I/O for FOUNDATION Fieldbus

By adding a FOUNDATION fieldbus Com Unit or gateway we have created a new FF Modular I/O to support all non FOUNDATION fieldbus signals. It makes use of established reliable hardware and employs standard FF multi-function blocks to offer a FF Modular I/O.

### FOUNDATION Fieldbus Inputs and Outputs – Digital or Analog

In contrast to dedicated digital input devices the FF Modular I/O approach allows you to combine analog and digital I/O in the same device. It supports NAMUR or switch type inputs as well as solenoid outputs, temperature signals or supply circuits for 2- or 4-wire transmitters, proportional valves and positioners. These often do not have a FOUNDATION fieldbus connection themselves.

The modular approach arrives at a very compact solution offering up to 40 digital inputs or outputs or 20 analog I/O or any combination of analog and digital I/O.

Example combinations:

- 24 digital inputs and 16 outputs
- 16 digital inputs and 8 outputs and 8 temperature inputs
- 16 digital inputs and 8 outputs and 8 analog inputs

Modules can be added within this framework whenever required. This allows for a modular expansion with modules on demand. Housings in GRP (**G**lass **F**ibre **R**einforced **P**olyester) or stainless steel also offer space for FieldBarriers and valve banks (see Figure 1).



FF Modular I/O

Bus Couplers

Accessories

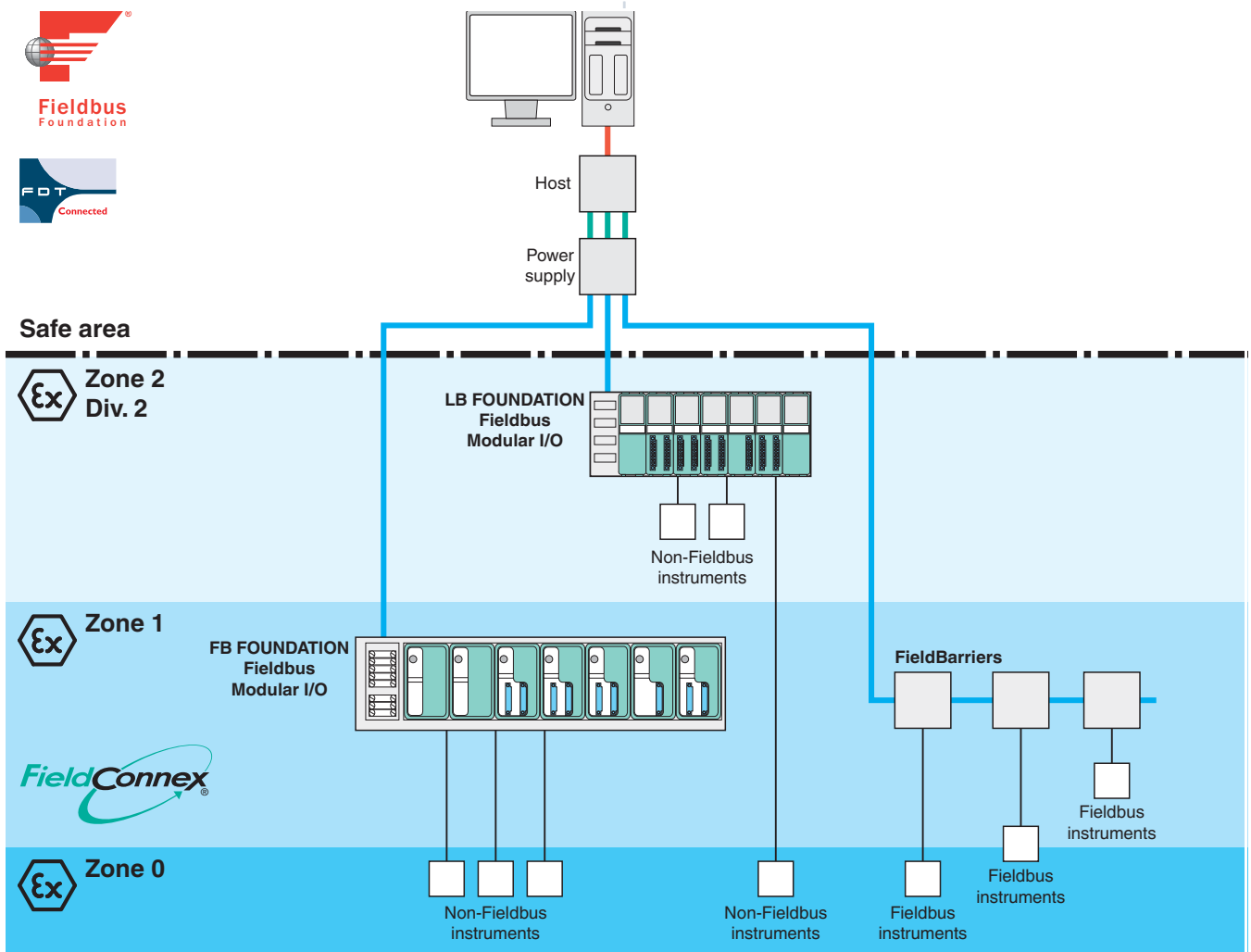

Figure 1 FOUNDATION fieldbus segment

### FOUNDATION Fieldbus Hardware Connection and Trunk Line Integrity

The FF Modular I/O can be regarded as any other individual FF device with several variables and therefore it can be connected directly to the high power trunk. It does not require segment protectors or IS FieldBarriers. Instead it uses Ex-e connections for explosion protection in the same way as a FieldBarrier.

The field loops are completely isolated and segregated from the trunk line. Therefore any work carried out on the field loops will not have any adverse effect on the trunk. A short of any input or output channel will not affect other channels. Modules including the gateway can be removed or inserted without jeopardizing the trunk.

The FF Modular I/O would often be the only participant in a segment depending on the timing required for the total number of I/O. If it is combined with a FieldBarrier on the same trunk a single segment protector would be sufficient. If a segment protector is not used caution would be needed, when installing or removing the complete FF Modular I/O carrier. Individual I/O modules however do not require such care since they are isolated from the trunk via the FF Modular I/O gateway.

Edition 912907 (US) / 220718 (EU) 06/2011



## FOUNDATION Fieldbus Response Times

The FOUNDATION fieldbus physical layer is based on IEC 61158-2. This bus uses 31.25 kBd transmission speeds. Employing single function blocks would have meant slow responses. It was therefore decided to make use of the most modern multi function blocks. These are already supported by most DCS vendors and offer much faster response times for data exchange.

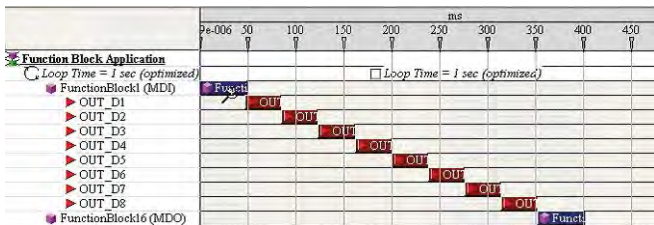

Figure 2 Timing for data transmission via FF trunk (host dependent)

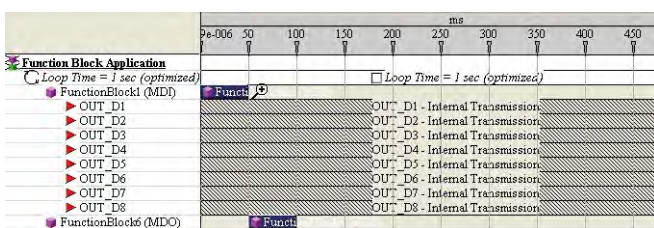

Figure 3 Timing for data acquisition from module to gateway using MFB (host independent)

Although the bus communication is governed by the FOUNDATION fieldbus standard and cannot be influenced, it was possible to reduce the internal execution time. While the FOUNDATION fieldbus spec requires discrete signals to be transported Bit by Bit, the use of MFB (Multi Function Block) has enabled us to prepare 8 digital signals for communication simultaneously. Looking at an eight channel digital input module a simple function block would take 8 internal cycles to store the Bits in the gateway ready for transmission to the host. Using a multi function block will achieve this in a single cycle.

Assuming that it takes 50 ms per Bit, a simple function block would result in all the data arriving in the gateway after 8 x 50 ms. Add to that the time it takes the host to collect the data via the fieldbus (350 ms see Figure 2), the total data acquisition time for 8 Bits would be 750 ms. These values largely depend on the host.

In contrast the multi function block MFB sends all 8 Bits to the gateway in one operation itself only taking 50 ms. The total data acquisition time therefore is just 350 ms + 50 ms = 400 ms using the same host (see Figure 3).

Equally if an input is directly linked to an output inside the FF Modular I/O, reaction times are much faster than when the signals have to be transmitted to the host and sent to another Fieldbus device.

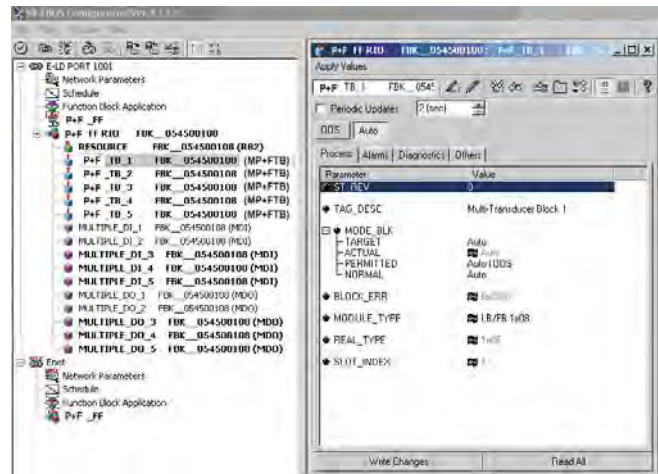

Figure 4 System integration example

## Host Integration via DD

The integration of the FF Modular I/O into suitable host DCS systems is accomplished by the well established DD technology (Device Description) and CFF (Configuration File) files. FOUNDATION fieldbus thus arrives at an easy to use configuration tool which is part of the DCS environment just as any other FF device. The FF certified files are available for download from the Pepperl+Fuchs and the FOUNDATION fieldbus websites.

## Safety Integrity Level (SIL2)

In the past safety applications with Remote I/O would always require additional discrete loops since the question of the SIL level of the bus would always have to be considered first.

In order to achieve functional safety independent of the bus we decided to develop a shutdown path totally unrelated to the bus (Figure 5).

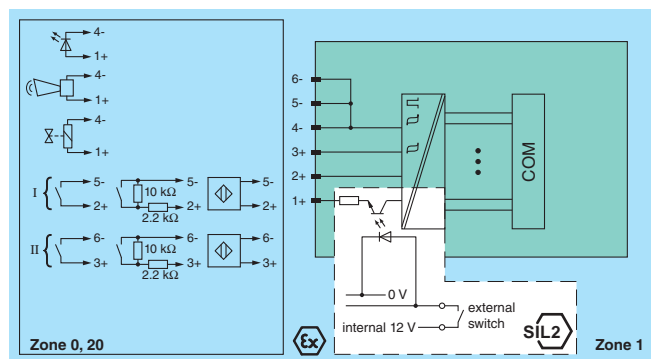

Figure 5 SIL2 valve shutdown circuit

This enables you to switch off outputs overriding the commands transmitted via the bus line. This is also possible with a FOUNDATION fieldbus installation.

Edition 06/2011 912907 (US) / 220718 (EU)

Pepperl+Fuchs has developed valve drivers which can be controlled via the bus as well as having a separate shutdown input which de-energizes outputs with a single action.

In order to avoid unnecessary diagnostic messages we do not simply turn off the power supply to the module but interrupt the output loop.

Modules without output shutdown inputs can be combined with modules with shutdown inputs in the same FF Modular I/O, if they are equipped with the shutdown contact. Modules without shutdown input are consistently controlled by the bus, independent of the setting of the external shutdown contact.

Modules with shutdown inputs are only controlled by the bus when the shutdown contact is closed. SIL2 safety parameters are available at request.

### Power Outputs

The FF Modular I/O does not load the bus by more than the 10 mA required by the standard since it derives its power from its own power supply. This makes it independent from the power available on the trunk line.

It drives digital as well as analogue output signals including high power IS solenoids or even increased safety power relays.

An added advantage can be seen in the fact that intrinsically safe loops can be operated directly adjacent to increased safety power circuits.

### HART Communication

Intelligent field devices which make use of the HART protocol can be connected to suitable analog input and output modules (models 3\*05, 4\*05). The field devices then become accessible via the service bus using appropriate communication software (e. g. **PACTware™**). There is also a HART communication DTM for other FDT containers to interface with our HART enabled gateway. The DTM is included in the standard setup. HART field devices are then engineered in the same way as they are with standard gateways and Com Units.

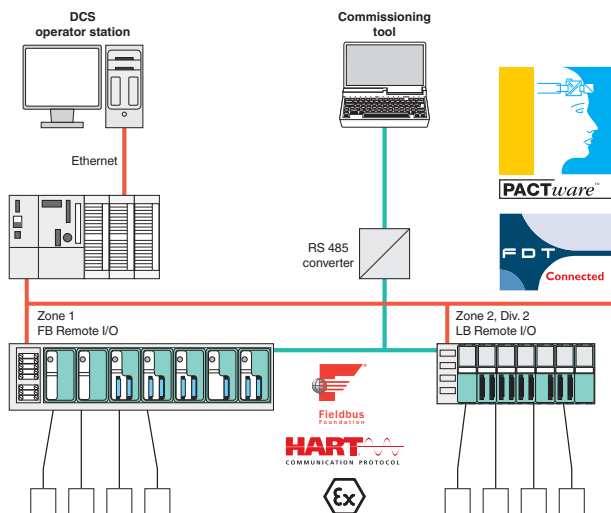

Figure 6 Example of HART communication via service bus

### Zones and Divisions

LB and FB Modular I/O are suitable for Zone 2 (LB) and Zone 1 (FB) gas hazardous area mounting.

The inputs and outputs can be connected to "ia" or "ib" loops in Zone 0 or Zone 1 depending on the module certificate. The enclosures must be hazardous area certified and must have a minimum IP54 ingress protection. Enclosures may be opened and modules may be hot swapped without the need for a hot work permit (see instructions).

When mounted in a suitable IP66 enclosure the modules can also be mounted in hazardous areas Zone 22 (LB) and Zone 21 (FB) for flammable dust. Do not open the enclosures and do not hot swapped the modules without a hot work permit.

Enclosures supplied by Pepperl+Fuchs are certified with the maximum number of modules that fit in the box. Therefore the user is permitted to add modules to fill empty spaces without having to contact us for recertification. It is also not necessary to recalculate the heat dissipation inside the enclosure since the maximum permissible power inside the enclosure has been considered for ATEX certification.

LB Modular I/O is also UL certified for Class 1/Div. 2 applications. The control drawings are available for download.

### Complete System with FieldBarrier for FOUNDATION Fieldbus

FOUNDATION fieldbus field devices can be directly connected to the fieldbus host using FieldBarriers. While the bus supplies the field devices it also enables digital communication via a single twisted pair (see Figure 1).

The FieldBarrier reduces the number of trunks in hazardous areas considerably compared with a totally intrinsically safe approach thus reducing cost.

The system architecture starts in the control room which is often connected to distributed controllers via Ethernet. These in turn use FF-H1 cards or FF-LINKs and segment power supplies or redundant power hubs to communicate with the field devices. Details about the properties of FieldBarriers can be found on the Internet under [www.pepperl-fuchs.com](http://www.pepperl-fuchs.com) or on the chapter on bus technologies.

Power and trunk lines are wired to the hazardous area using Ex-e increased safety techniques. This eliminates the need for energy limitations normally encountered with intrinsic safety.

The field devices use the traditional intrinsic safety wiring to FISCO or ENTITY. The FF Modular I/O can take on various shapes within this concept (see Figure 7 to Figure 9). They are also available in stainless steel enclosures.

Edition 912907 (US) / 220718 (EU) 06/2011



FF Modular I/O

Bus Couplers

Accessories

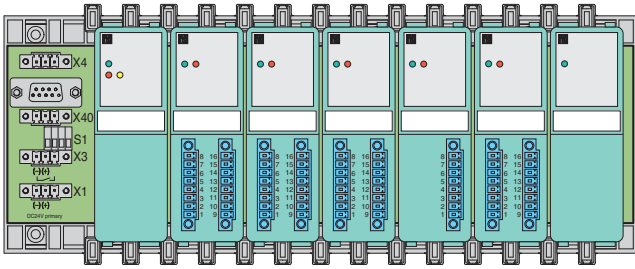

Figure 7 Installation outside hazardous areas, or in suitable enclosures in Zone 2, Zone 22 or Div. 2

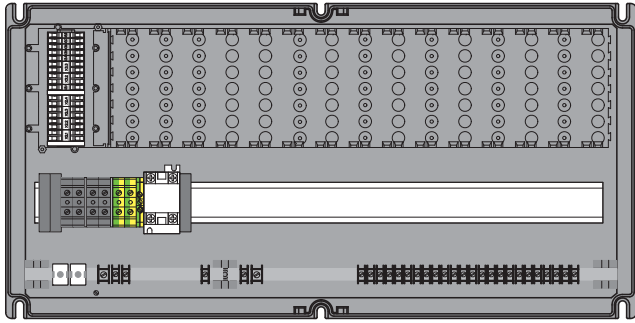

Figure 8 Installation in suitable enclosures in Zone 1 or Zone 21

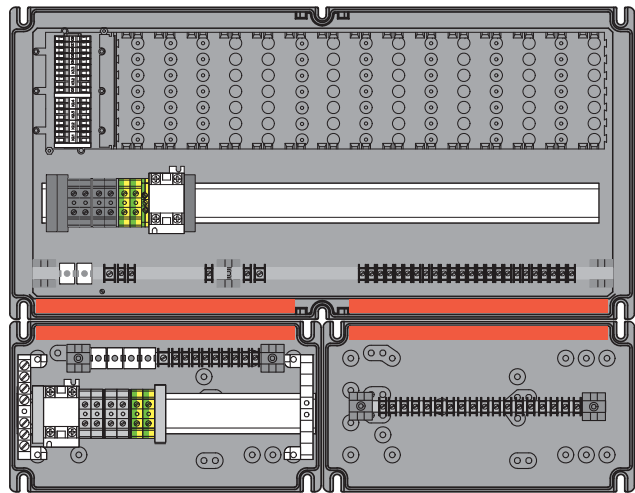

Figure 9 Installation in suitable enclosures in Zone 1 or Zone 21 with space for FieldBarrier

**Bus Couplers (Gateways)**

| Model Number | Channels per Station <sup>1</sup> |         | Stations per Bus Line <sup>1</sup> |                      | Configuration via System | HART Communication | Mounting in   |                              | Page |
|--------------|-----------------------------------|---------|------------------------------------|----------------------|--------------------------|--------------------|---|------------------------------|------|
|              | Analog                            | Digital | Fieldbus H1                        | Service Bus (Option) |                          |                    | Suitable Enclosures in Zone 1 and Zone 2 <sup>1</sup> | Zone 2 and Zone 22 or Div. 2 |      |
| LB 8110 H*** | 20                                | 40      | 1 or 2                             | 119                  | ■                        | ■                  |   | ■                            | 276  |
| FB 8210 H*** | 20                                | 40      | 1 or 2                             | 119                  | ■                        | ■                  | ■   |                              | 277  |

<sup>1</sup> see data sheet for details



**Features**

- Interface between the I/O modules and the DCS/PLC
- Bus coupler for 20 analog or 40 digital channels
- Communication via FOUNDATION Fieldbus H1
- HART communication via service bus
- Configured via the DCS
- Non-volatile memory for configuration and parameter settings
- Supports multichannel I/O modules
- Installation in Zone 2 and 22 or Div. 2 and safe area
- EMC acc. to NAMUR NE 21

**Function**

The ComUnit, bus coupler or gateway links intrinsically safe inputs and outputs from sensors and actuators to FOUNDATION Fieldbus.

It makes use of dual width I/O modules and thus transports signals from NAMUR and switch type inputs and high power IS solenoids or even power relays as well as sounders, and alarm LEDs.

The system supplies 4-20 mA transmitters and accepts inputs from 20 mA current sources or temperature sensors. It drives I/P converters and proportional valves and positioners.

The ComUnit supports ONLINE configuration as well as HART. It is well integrated into renowned DCS and PLC systems.

**Technical data**

|   |  |
|---|--|
| <b>Supply</b>   |  |
| Rated voltage   | 5 V DC, only in connection with the power supplies LB 9***   |
| <b>Fieldbus interface</b>                                       |  |
| FOUNDATION Fieldbus   |  |
| Baud rate   | 31.25 kBit/s, MBP  |
| Protocol  | H1 to IEC 1158-2   |
| Number of stations per bus line                                 | 1 or 2, depending on the required response times   |
| Number of channels per station                                  | ≤20 analog, ≤40 digital  |
| Supported I/O modules   | 5 slots, to be filled with (combinations possible):<br>1*08 digital input, 8-channel, NAMUR<br>3104 analog input, 4-channel, 20 mA (HART via handheld only), 3*05 analog input, 4-channel, 20 mA (HART via service bus)<br>4104 analog output, 4-channel, 20 mA (HART via handheld), 4*05 analog output, 4-channel, 20 mA (HART via service bus)<br>5*04 Pt100 RTD input, 4-channel, 5*05 thermocouple input, 4-channel<br>6005 relay output, 4-channel, 230 V, 6006 relay output, 8-channel, 24 V, 6*08 digital output, 8-channel, Ex-i, 6*10-6*15 digital output, 4-channel, Ex-i power<br>* = variable (0 = non-IS, 1 = IS) |
| Bus length  | ≤1900 m (must not be exceeded by the sum of all trunk and spur lines)  |
| Spur length   | ≤120 m (depending on the number of field devices. Modular I/O station = 1 field device)  |
| <b>Ambient conditions</b>                                       |  |
| Ambient temperature   | -20 ... 60 °C (-4 ... 140 °F)  |
| <b>Mechanical specifications</b>                                |  |
| Mass  | approx. 150 g  |
| Dimensions  | 32 x 100 x 103 mm (1.26 x 3.9 x 4 in)  |
| <b>Data for application in connection with Ex-areas</b>         |  |
| Supply  | only in connection with the power supplies LB 9***   |
| Declaration of conformity                                       | PF 08 CERT 1234  |
| Group, category, type of protection, temperature classification | ⊕ II 3 G Ex nA IIC T4  |
| Directive conformity  |  |
| Directive 94/9/EC   | EN 60079-0, EN 60079-15  |
| <b>International approvals</b>                                  |  |
| UL approval   | E106378  |
| IECEX approval  | BVS 09.0037X   |

**Diagrams**

Front view

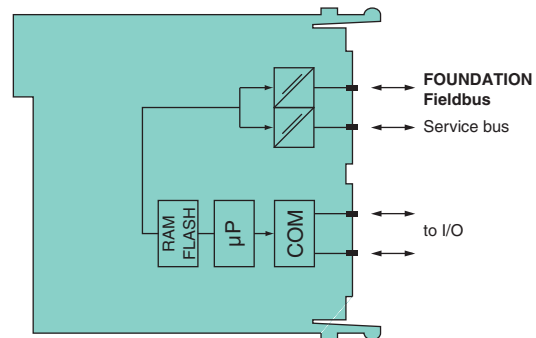
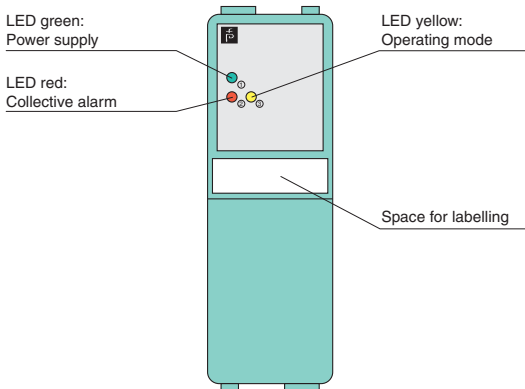

Zone 2  
Div. 2

Edition 912907 (US) / 220718 (EU) 06/2011

| Technical data  |  |
|---|--|
| <b>Supply</b>   |  |
| Rated voltage   | 5 V DC, only in connection with the power supplies FB 92**   |
| <b>Fieldbus interface</b>                               |  |
| FOUNDATION Fieldbus                                     |  |
| Baud rate   | 31.25 kBit/s, MBP  |
| Number of stations per bus line                         | 1 or 2, depending on the required response times   |
| Number of channels per station                          | ≤20 analog, ≤40 digital  |
| Supported I/O modules                                   | 5 slots, to be filled with (combinations possible):<br>1*08 digital input, 8-channel, NAMUR<br>3204 analog input, 4-channel, 20 mA (HART via handheld only), 3*05 analog input, 4-channel, 20 mA (HART via service bus)<br>4204 analog output, 4-channel, 20 mA (HART via handheld), 4*05 analog output, 4-channel, 20 mA (HART via service bus)<br>5204 Pt100 RTD input, 4-channel<br>5205 thermocouple input, 4-channel<br>6305 relay output, 4-channel, 230 V<br>6306 relay output, 8-channel, 24 V<br>6*08 digital output, 8-channel<br>6210-6215 digital output, 4-channel, Ex-i power<br>* = variable (2 = IS, 3 = Ex-e) |
| Bus length  | ≤1900 m (must not be exceeded by the sum of all trunk and spur lines)  |
| Spur length   | ≤120 m (depending on the number of field devices.<br>Modular I/O station = 1 field device)   |
| <b>Ambient conditions</b>                               |  |
| Ambient temperature                                     | -20 ... 60 °C (-4 ... 140 °F)  |
| <b>Mechanical specifications</b>                        |  |
| Protection degree                                       | IP20 (module), a separate housing is required acc. to the system description   |
| Connection  | via backplane  |
| Mass  | approx. 750 g  |
| Dimensions  | 57 x 107 x 132 mm (2.2 x 4.2 x 5.2 in)   |
| <b>Data for application in connection with Ex-areas</b> |  |
| EC-Type Examination Certificate                         | PTB 97 ATEX 1074 U, PTB 97 ATEX 1075 (system)  |
| Group, category, type of protection                     | ⊕ II 2 G Ex d II C   |
| Supply  | only in connection with the power supplies FB 92**   |
| <b>Directive conformity</b>                             |  |
| Directive 94/9/EC                                       | EN 60079-0, EN 60079-1   |
| <b>International approvals</b>                          |  |
| IECEx approval  | pending  |

**Features**

- Interface between the I/O modules and the DCS/PLC
- Bus coupler for 20 analog or 40 digital channels
- Communication via FOUNDATION fieldbus H1
- HART communication via service bus
- Non-volatile memory for configuration and parameter settings
- Module can be exchanged under voltage in Zone 1 (hot swap)
- Supports multichannel I/O modules
- Installation in suitable enclosures in Zone 1 and Zone 21
- EMC acc. to NAMUR NE 21

**Function**

The ComUnit, bus coupler or gateway links intrinsically safe inputs and outputs from sensors and actuators to FOUNDATION Fieldbus.

It makes use of dual width I/O modules and thus transports signals from NAMUR and switch type inputs and high power IS solenoids or even power relays as well as sounders, and alarm LEDs.

The system supplies 4-20 mA transmitters and accepts inputs from 20 mA current sources or temperature sensors. It drives I/P converters and proportional valves and positioners.

The ComUnit supports ONLINE configuration as well as HART. It is well integrated into renowned DCS and PLC systems.

**Diagrams**

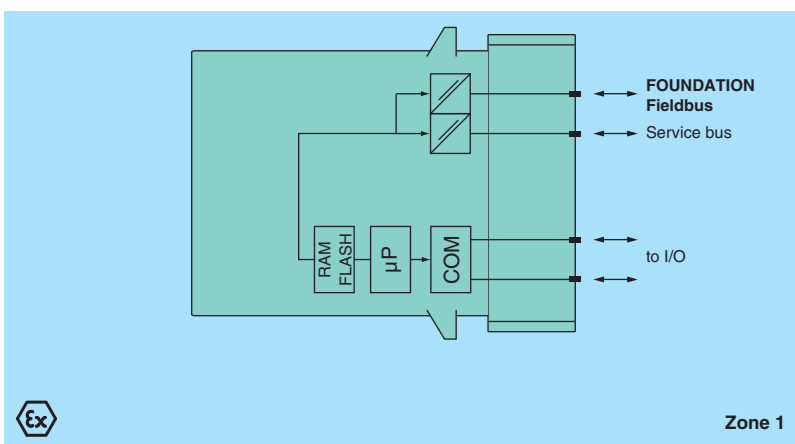

Front view

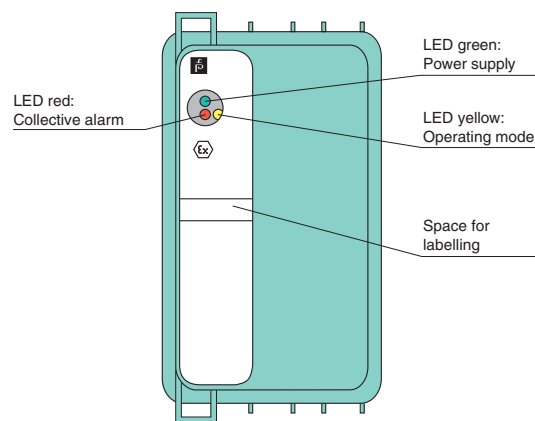

Edition 912907 (US) / 220718 (EU) 06/2011

Subject to modifications without notice

Pepperl+Fuchs Group  
www.pepperl-fuchs.com

USA: +1 330 486 0002  
pa-info@us.pepperl-fuchs.com

Germany: +49 621 776 2222  
pa-info@de.pepperl-fuchs.com

Copyright Pepperl+Fuchs  
Singapore: +65 6779 9091  
pa-info@sg.pepperl-fuchs.com



FF Modular I/O

Bus Couplers

Accessories

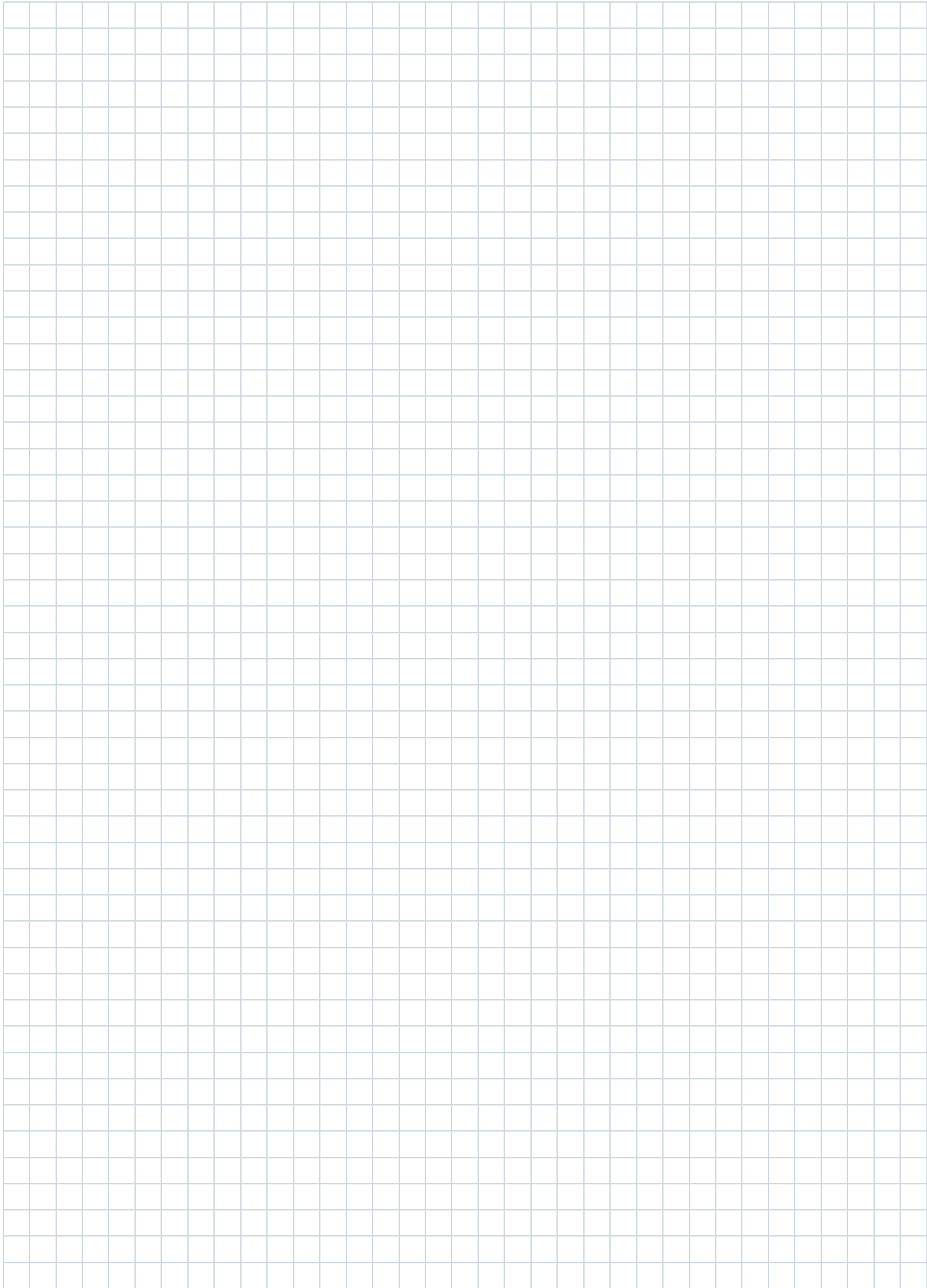

Edition 912907 (US) / 220718 (EU) 06/2011

**Backplanes**

| Model Number | Base Backplane | max. Number of Double Width Modules | FOUNDATION Fieldbus H1 | Mounting in Zone 2 and Zone 22 or Div. 2 | Page |
|--------------|----------------|-------------------------------------|------------------------|--|------|
| LB 9035 A    | ■              | 5                                   | ■                      | ■  | 280  |

**Field Units (Enclosures)**

| Model Number          | Field Unit | max. Number of Slots | Material        |                 | FOUNDATION Fieldbus H1 | Mounting in Zone 1 and Zone 21 | Mounting in Zone 2 and Zone 22 or Div. 2 | Page |
|-----------------------|------------|----------------------|-----------------|-----------------|------------------------|--------------------------------|--|------|
|                       |            |                      | Stainless Steel | Polyester (GRP) |                        |                                |  |      |
| LB 9510-S90-0-0-1-0-F | ■          | 5                    | ■               |                 | ■                      |                                | ■  | 281  |
| FB 9210-PB0-0-0-0-0-F | ■          | 5                    |                 | ■               | ■                      | ■                              |  | 282  |



FF Modular I/O

Bus Couplers

Accessories





**Features**

- Max. 5 slots for I/O modules (dual width only)
- Installation in Zone 2 and Zone 22 or Class I, Div. 2 or safe area
- For FOUNDATION fieldbus H1
- Backplane for LB-System

**Technical data**

|   |  |
|---|--|
| <b>Slots</b>  |  |
| Bus coupler   | 1  |
| Supply  | 1  |
| I/O modules (dual width)  | max. 5   |
| <b>Supply</b>   |  |
| Rated voltage   | 24 V DC  |
| Redundancy  | no   |
| <b>Fieldbus interface</b>                                       |  |
| Fieldbus type   | FOUNDATION fieldbus H1   |
| Redundancy  | no   |
| <b>Mechanical specifications</b>                                |  |
| Protection degree   | IP20   |
| Dimensions  | (W x H x D)<br>275 x 127 x 80 mm (10.8 x 5 x 3.15 in), without modules |
| <b>Data for application in connection with Ex-areas</b>         |  |
| Declaration of conformity                                       | PF 08 CERT 1234  |
| Group, category, type of protection, temperature classification | Ex II 3G Ex nA IIC T4  |
| Directive conformity  |  |
| Directive 94/9/EC   | EN 60079-0:2006, EN 60079-15:2005                                      |
| <b>International approvals</b>                                  |  |
| IECEx approval  | BVS 09.0037X   |

**Diagrams**

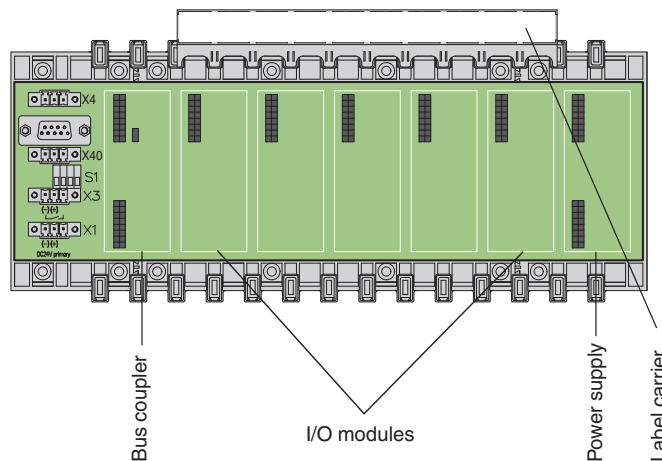

Edition 912907 (US) / 220718 (EU) 06/2011

**Technical data**

**Mechanical specifications**

|                   |   |
|-------------------|---|
| Dimensions        | (W x H x D) 350 x 306 x 215 mm (13.8 x 12 x 8.5 in) |
| Material          |   |
| Housing           | stainless steel 1.4404/AISI 316L                    |
| Surface           | electropolished                                     |
| Cable gland       | Polyamide (PA)                                      |
| Protection degree | IP66, NEMA 4x                                       |
| Mass              | approx. 10 kg, without modules                      |
| Mounting          | clearance holes Ø11 mm                              |
| Grounding         | grounding bolt M10, brass                           |

**Ambient conditions**

|                     |   |
|---------------------|---|
| Ambient temperature | -20 ... 55 °C (-4 ... 131 °F) at T4, depending on the permissible power |
| Storage temperature | -40 ... 70 °C (-40 ... 158 °F)  |

**General specifications**

|                      |                     |
|----------------------|---------------------|
| Installed components | backplane LB 9035 A |
|----------------------|---------------------|

**Slots**

|                          |        |
|--------------------------|--------|
| Bus coupler              | 1      |
| Supply                   | 1      |
| I/O modules (dual width) | max. 5 |

**Supply**

|               |   |
|---------------|---|
| Connection    | screw terminals, max. 2.5 mm <sup>2</sup> |
| Rated voltage | 24 V DC                                   |
| Redundancy    | no  |

**Fieldbus interface**

|            |  |
|------------|--|
| Connection | wire clamp terminals, max. 2.5 mm <sup>2</sup> |
| Redundancy | no   |

**Data for application in connection with Ex-areas**

|                                     |  |
|-------------------------------------|--|
| EC-Type Examination Certificate     | PTB 03 ATEX 2042   |
| Group, category, type of protection | ⓧ II (1) G [Ex ia] IIC/IIB<br>ⓧ II (2) G [Ex ib] IIC<br>ⓧ II (1) D [Ex ia D]<br>ⓧ II (2) D [Ex ib D] |

**Declaration of conformity**

|   |  |
|---|--|
| Group, category, type of protection, temperature classification | ⓧ II 3 G Ex nA nC [ic] IIC/IIB T4<br>ⓧ II 3 (2) G Ex nA nC [ib] IIC T4<br>ⓧ II 3 (1) G Ex nA nC [ia] IIC/IIB T4<br>ⓧ II 3 D Ex tD A22 IP65 T 130°C<br>ⓧ II (2) D [Ex ib] IIIC<br>ⓧ II (1) D [Ex ia] IIIC |
|---|--|

**Features**

- Max. 5 slots for I/O modules (dual width only)
- Installation in Zone 2 and Zone 22 or Class I, Div. 2 or safe area
- Electropolished enclosure, IP66/NEMA 4x
- For FOUNDATION fieldbus H1
- Packaged certified solution
- Standard enclosure for LB-System

**Function**

This field unit is designed to meet the requirements of the most demanding industrial environmental applications.

Electropolished stainless steel 316L provides high corrosion resistance for both onshore and offshore installations. The one piece seal is protected from standing water damage by the box's integral rain channel.

It is equipped with plug-in slots for 5 dual width I/O modules. Any I/O module can be inserted into any slot, enabling a mixture of I/O types in one field unit.

**Diagrams**

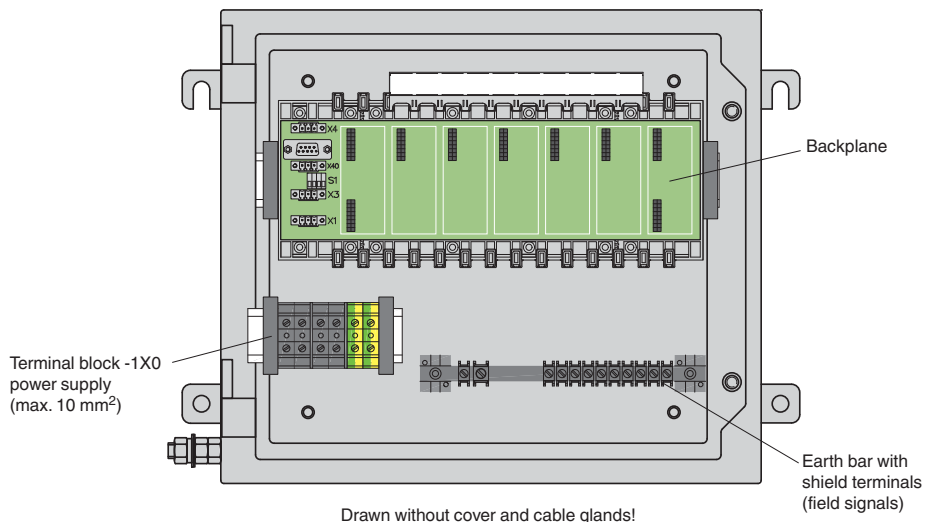

Drawn without cover and cable glands!

Edition 912907 (US) / 220718 (EU) 06/2011

Subject to modifications without notice

Pepperl+Fuchs Group  
www.pepperl-fuchs.com

USA: +1 330 486 0002  
pa-info@us.pepperl-fuchs.com

Germany: +49 621 776 2222  
pa-info@de.pepperl-fuchs.com

Copyright Pepperl+Fuchs  
Singapore: +65 6779 9091  
pa-info@sg.pepperl-fuchs.com



FF Modular I/O

Bus Couplers

Accessories



FF Modular I/O

Bus Couplers

Accessories

**Features**

- Max. 5 slots for I/O modules
- Installation in Zone 1 and Zone 21
- Impact resistance enclosure, IP66/NEMA 4x
- For FOUNDATION fieldbus H1
- Packaged certified solution
- Standard enclosure for FB-System

**Function**

This field unit is designed to meet the requirements of the most demanding hazardous area and industrial environmental applications.

Glass-fiber reinforced polyester provides high corrosion resistance for both onshore and offshore installations. Electrostatic charge is avoided by suitable surface resistance.

It is equipped with plug-in slots for 5 dual width I/O modules.

Any I/O module can be inserted into any slot, enabling a mixture of I/O types in one field unit.

**Technical data**

**Mechanical specifications**

|                   |   |
|-------------------|---|
| Dimensions        | (W x H x D) 544 x 271 x 210 mm (21.4 x 10.7 x 8.3 in) |
| Protection degree | IP66, NEMA 4x   |
| Material          |   |
| Housing           | polyester, impact resistant, glass fiber reinforced   |
| Surface           | black molded finish (RAL 9005)                        |
| Cable gland       | Polyamide (PA)  |
| Mass              | approx. 10 kg, without modules                        |
| Enclosure cover   | detachable cover with retaining screws                |
| Mounting          | clearance holes Ø6.5 mm                               |

**Ambient conditions**

|                     |  |
|---------------------|--|
| Ambient temperature | -20 ... 55 °C (-4 ... 131 °F) at T4<br>-20 ... 40 °C (-4 ... 104 °F) at T6 |
| Storage temperature | -40 ... 70 °C (-40 ... 158 °F)   |

**Slots**

|                          |        |
|--------------------------|--------|
| Bus coupler              | 1      |
| Supply                   | 1      |
| I/O modules (dual width) | max. 5 |

**Supply**

|               |  |
|---------------|--|
| Connection    | screw terminals, max. 10 mm <sup>2</sup>           |
| Rated voltage | 24 V DC/115 V AC/230 V AC, depends on power supply |
| Redundancy    | no   |

**Fieldbus interface**

|            |  |
|------------|--|
| Connection | wire clamp terminals, max. 2.5 mm <sup>2</sup> |
| Redundancy | no   |

**Electrical specifications**

|                   |              |
|-------------------|--------------|
| Permissible power | 34 W (DC/AC) |
|-------------------|--------------|

**Data for application in connection with Ex-areas**

|   |  |
|---|--|
| EC-Type Examination Certificate                                 | PTB 97 ATEX 1075   |
| Group, category, type of protection, temperature classification | ⓧ II 2(1)G EEx dem [ia] IIC T4/T6<br>ⓧ II 2(1)D IP66 T80°C<br>ⓧ II (1)D [Ex ia] IIIC<br>ⓧ II (2)D [Ex ib] IIIC |

**Directive conformity**

|                   |  |
|-------------------|--|
| Directive 94/9/EC | EN 60079-0:2009, EN 60079-1:2007, EN 60079-7:2003, EN 60079-18:2004, EN 60079-11:2007, EN 61010-1:2001, EN 61241-11:2006 |
|-------------------|--|

**International approvals**

|         |               |
|---------|---------------|
| INMETRO | 2008EC02CP011 |
|---------|---------------|

**Diagrams**

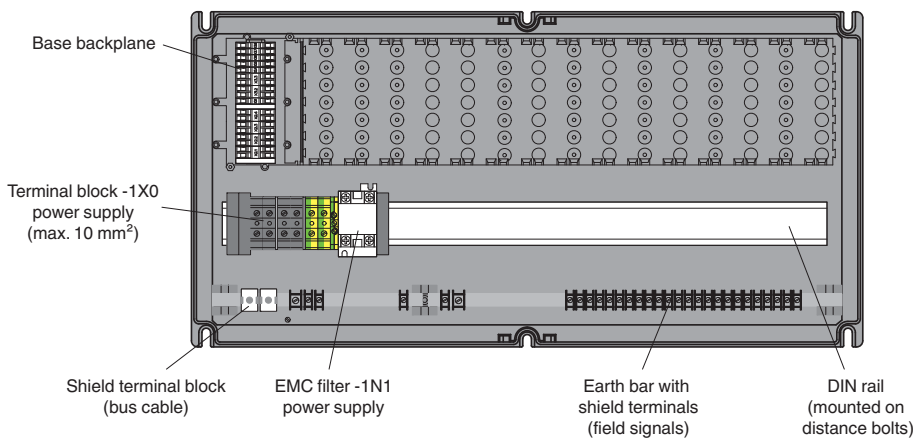

Drawn without cover and cable glands!

Edition 9/12907 (US) / 220718 (EU) 06/2011

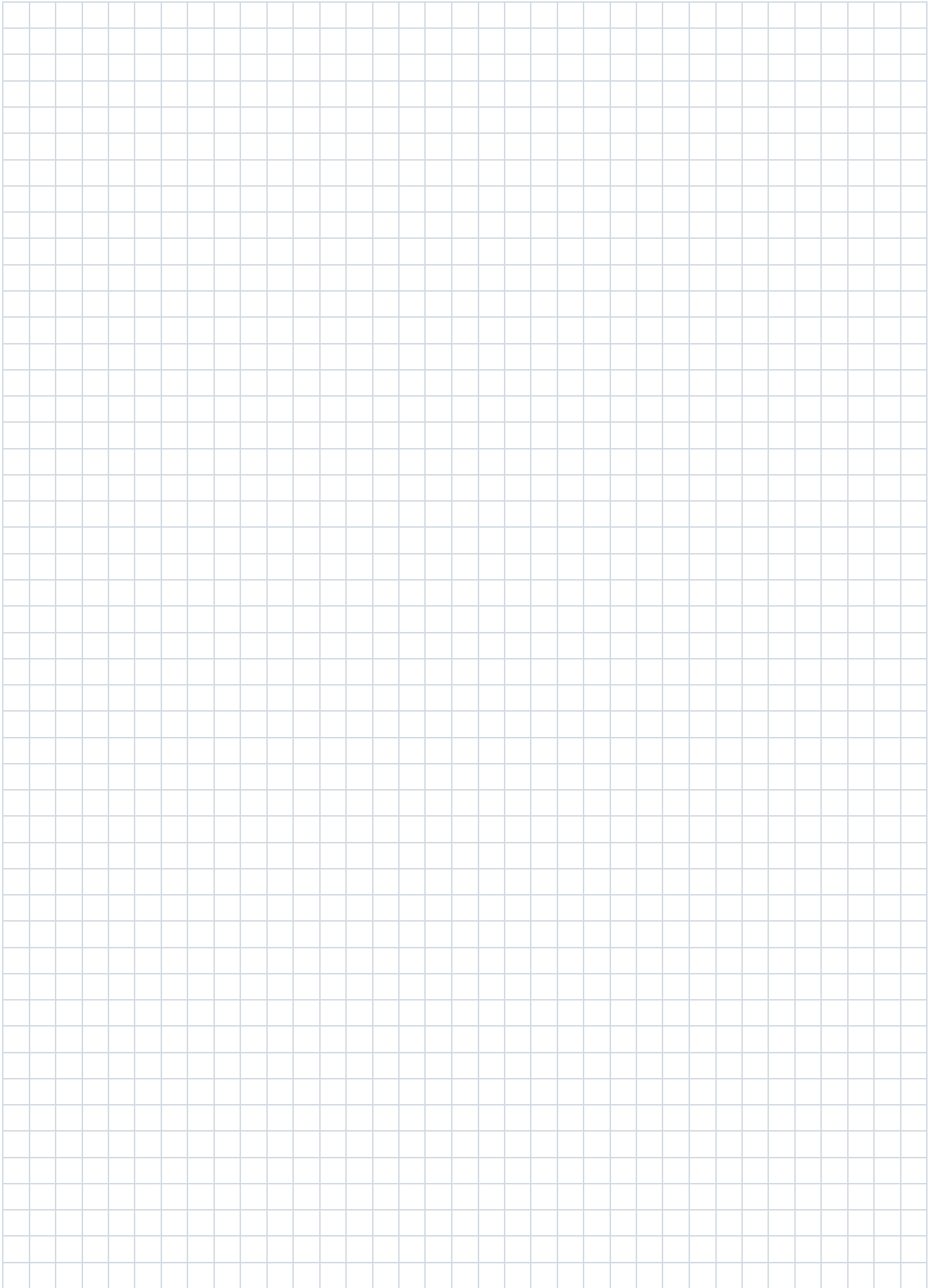

Edition 912907 (US) / 220718 (EU) 06/2011

Subject to modifications without notice

Pepperl+Fuchs Group  
www.pepperl-fuchs.com

USA: +1 330 486 0002  
pa-info@us.pepperl-fuchs.com

Germany: +49 621 776 2222  
pa-info@de.pepperl-fuchs.com

Copyright Pepperl+Fuchs  
Singapore: +65 6779 9091  
pa-info@sg.pepperl-fuchs.com





# PROFIBUS Fibre Optic Link



Edition 912907 (US) / 220718 (EU) 05/2011

## Fibre Optic Link in Zone 1 for PROFIBUS DP/DPV1

### Fibre Optic Links in the Safe Area

Fibre Optic Links mounted in the safe area also require ATEX certification if the fibres have to be energy limited in order to be connected to repeaters in the hazardous area. Suitable safe area FOLs are available at request.

### Fibre Optic Links in Zone 1

In Zone 1 hazardous areas certified Fibre Optic Links must be used. Power supply and standard RS 485 PROFIBUS connections are to be wired using increased safety regulations. Fibre optic cables are intrinsically safe.

## PROFIBUS Fibre Optic Link FOL



- Suitable for PROFIBUS connections with actuators, converters, motors, valves, positioners, drives etc.
- Fibre Optic Links act as repeaters at high transmission rates and for long distances
- Excellent noise immunity
- Automatic recognition of the PROFIBUS data rate
- Star, ring, and line topologies are selectable
- Recognizes PROFIBUS redundancy change-overs
- LED diagnostic for transmit and receive lines
- Test terminals to check the signal amplitude
- Bus termination can be activated via switch
- Mounted in Zone 1, Zone 2, Zone 21, Zone 22



PROFIBUS FOL

Products



# PROFIBUS Fibre Optic Link



912907 (US) / 220718 (EU) 05/2011

Edition



**System Description** ..... 288

**Products**

**Selection Tables** ..... 289

**Product Data Sheets** ..... 290





In PROFIBUS applications Fibre Optic Links are used to bridge long distances at high transmission speeds. While copper cables only reach 200 m at 1.5 kBit/s optical links can extend this to 3,000 m depending on the type of fibre.

## Fibre Optic Links in the Safe Area

Fibre Optic Links mounted in the safe area also require ATEX certification if the optical cables have to be energy limited in order to be connected to repeaters in the hazardous area. Here the DIN rail mounted FOL can be used.

## Fibre Optic Links in Zone 1

In Zone 1 hazardous areas certified Fibre Optic Links must be used. The FOL must be mounted in a suitable enclosure. This can be the dedicated and certified FOL enclosure or a bigger enclosure with DIN mounting rails. In this case an overall certificate for the installation in hazardous areas must be obtained. Alternatively our engineers are certified to issue the necessary paperwork together with our certificate when the enclosure is supplied from our own workshop.

Power supply and standard RS 485 PROFIBUS connections are to be wired using increased safety regulations. Fibre optic cables are intrinsically safe.

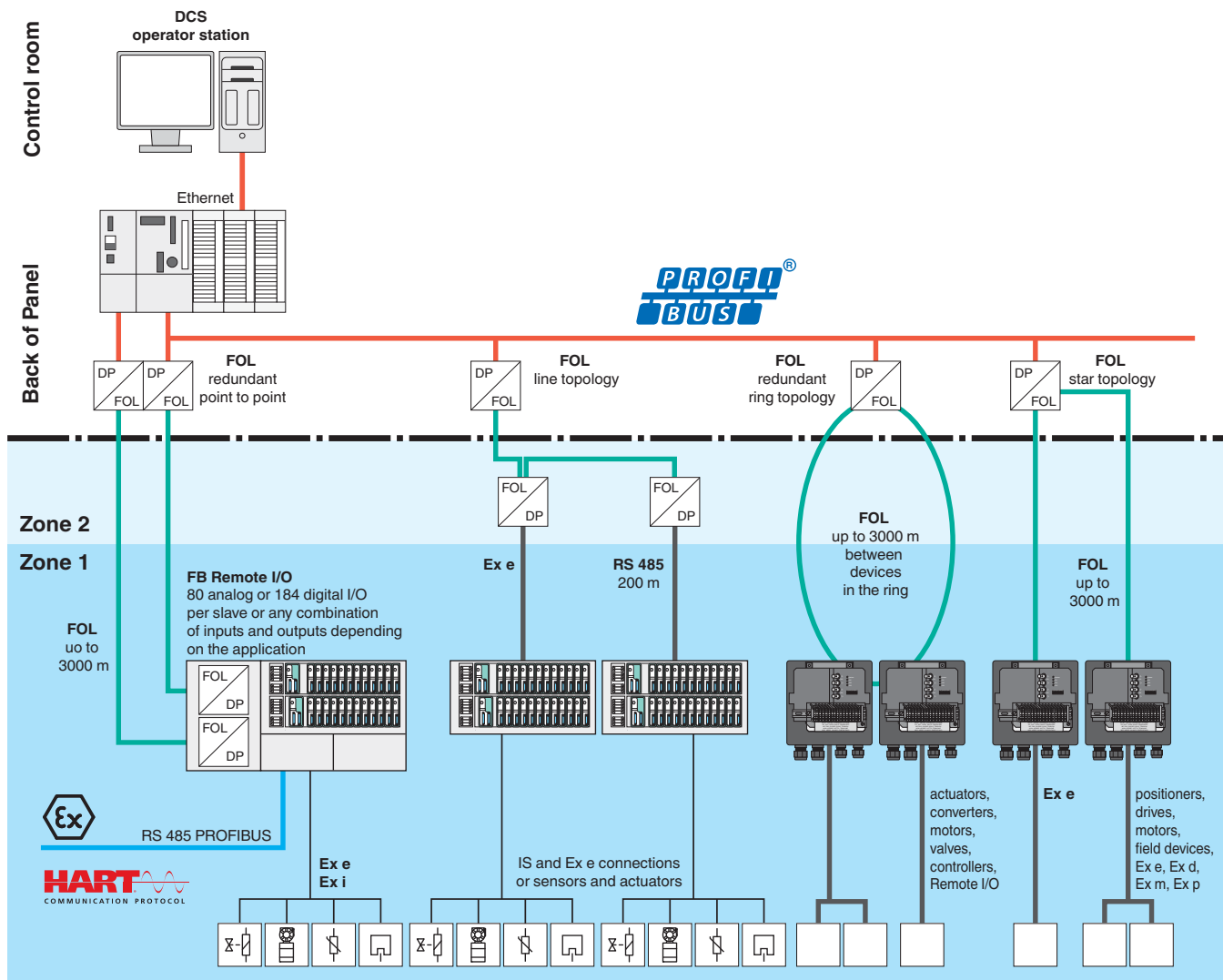

Figure 1 Fibre Optic Link in Zone 1 for PROFIBUS DP V1

Edition 912907 (US) / 220718 (EU) 06/2011

| Model Number   | PROFIBUS Interface | Automatic Baud Rate Detection | Star, Ring, or Line Topology Selectable | Mounting Options |                    |                            | Page |
|----------------|--------------------|-------------------------------|---|------------------|--------------------|----------------------------|------|
|                |                    |                               |   | on DIN Rail      | in Plastic Housing | in Stainless Steel Housing |      |
| FOL 7250 B 059 | ■                  | ■                             | ■                                       | ■                |                    |                            | 290  |
| FOL 7250 B 159 | ■                  | ■                             | ■                                       |                  | ■                  |                            | 290  |
| FOL 7250 B 259 | ■                  | ■                             | ■                                       |                  |                    | ■                          | 290  |



**Features**

- For any PROFIBUS interface, e. g. Remote I/O, valves, drives, inverters, motors, controllers etc.
- Full galvanic isolation between field and control room
- Very high noise immunity since insusceptible to electromagnetic fields
- No sparks capable of ignition or hot surfaces due to low light energies
- Automatic baud rate detection
- Star, ring, or line topology selectable
- Bridging of great distances while maintaining high transmission rates

**Function**

The Profibus-Fibre Optic Coupler and Repeater FOL 7250 converts Profibus into fibre optic signals and vice versa. Thus, great distances can be bridged even at high transmission rates (1,000 m at 1.5 Mbit/s) while complete galvanic isolation between field and control room is guaranteed.

The FOL 7250 can be used both as a point-to-point coupler and in a redundant ring. It automatically adapts to the Profibus transmission rate, detects line faults and performs an automatic redundancy switchover.

**Technical data**

|   |  |
|---|--|
| <b>Supply</b>   |  |
| Connection  | redundant  |
| Rated voltage   | 18 ... 32 V, typical: 24 V   |
| <b>Fieldbus interface</b>                                       |  |
| Fieldbus type   | PROFIBUS DP, DP V1, DP V2, FMS   |
| <b>Electrical specifications</b>                                |  |
| Signal delay  | < 6.5 bit times  |
| Signal contact (safety extra-low voltage)                       | max. DC 60 V, AC 24 V, 1 A (Ex-e)  |
| <b>Fiber optics (LWL)</b>                                       |  |
| Wave length   | 860 nm   |
| Optical input power   | min. -28 dBm, max. -3 dBm  |
| Launchable optical power  | in multi-mode fibre (50/125):<br>(50/125): -15 dBm<br>(62,5/125): -13 dBm  |
| Cable length  | Multi-mode fibre (MM) 50/125: 3000 m, 13 dB link budget at 860 nm; A = 3 dB/km; 3 dB buffer<br>Multi-mode fibre (MM) 62.5/125: 3000 m, 15 dB link budget at 860 nm; A = 3.5 dB/km; 3 dB buffer |
| Connector type  | BFOC/2.5   |
| <b>Ambient conditions</b>                                       |  |
| Ambient temperature   | -20 ... 60 °C (-4 ... 140 °F) module, 55 °C (131 °F) housing   |
| Storage temperature   | -40 ... 85 °C (-40 ... 185 °F)   |
| <b>Mechanical specifications</b>                                |  |
| Protection degree   | IP66, if plastic or stainless steel housing is used  |
| <b>Cable</b>  |  |
| Length L  | 200 m ... 1000 m, depending on baud rate   |
| Mass  | 1500 g (DIN rail module), 2400 g (plastic housing), 3700 g (stainless steel housing).  |
| Dimensions  | 156 x 125 x 75 mm (Module),<br>165 x 194 x 138 mm (plastic housing),<br>230 x 219 x 108 mm (stainless steel housing)   |
| Mounting  | DIN rail mounting  |
| <b>Data for application in connection with Ex-areas</b>         |  |
| EC-Type Examination Certificate                                 | Coupler in housing: PTB 04 ATEX 1030<br>Coupler as DIN rail module: PTB 07 ATEX 2021 X   |
| Group, category, type of protection, temperature classification | Coupler in housing:<br>Ⓢ II 2 G Ex e mb [ib] op is IIC T4,<br>Ⓢ II 2 D Ex tD A21 IP66 T130°C<br>Coupler as DIN rail module:<br>Ⓢ II 2 G Ex e mb [ib] op is IIC T4                              |

**Diagrams**

FOL 7250 B 059

FOL 7250 B 159

FOL 7250 B 259

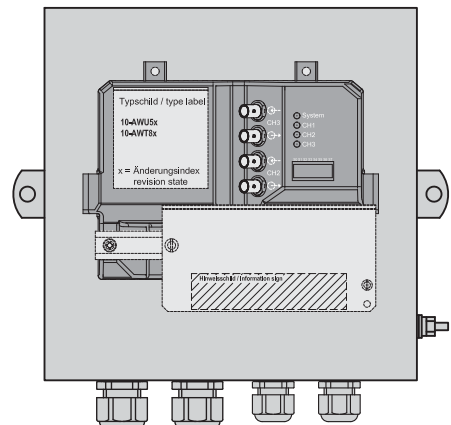
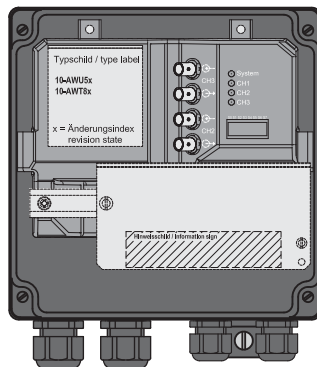
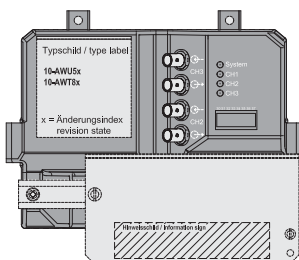

Edition 912907 (US) / 220718 (EU) 06/2011

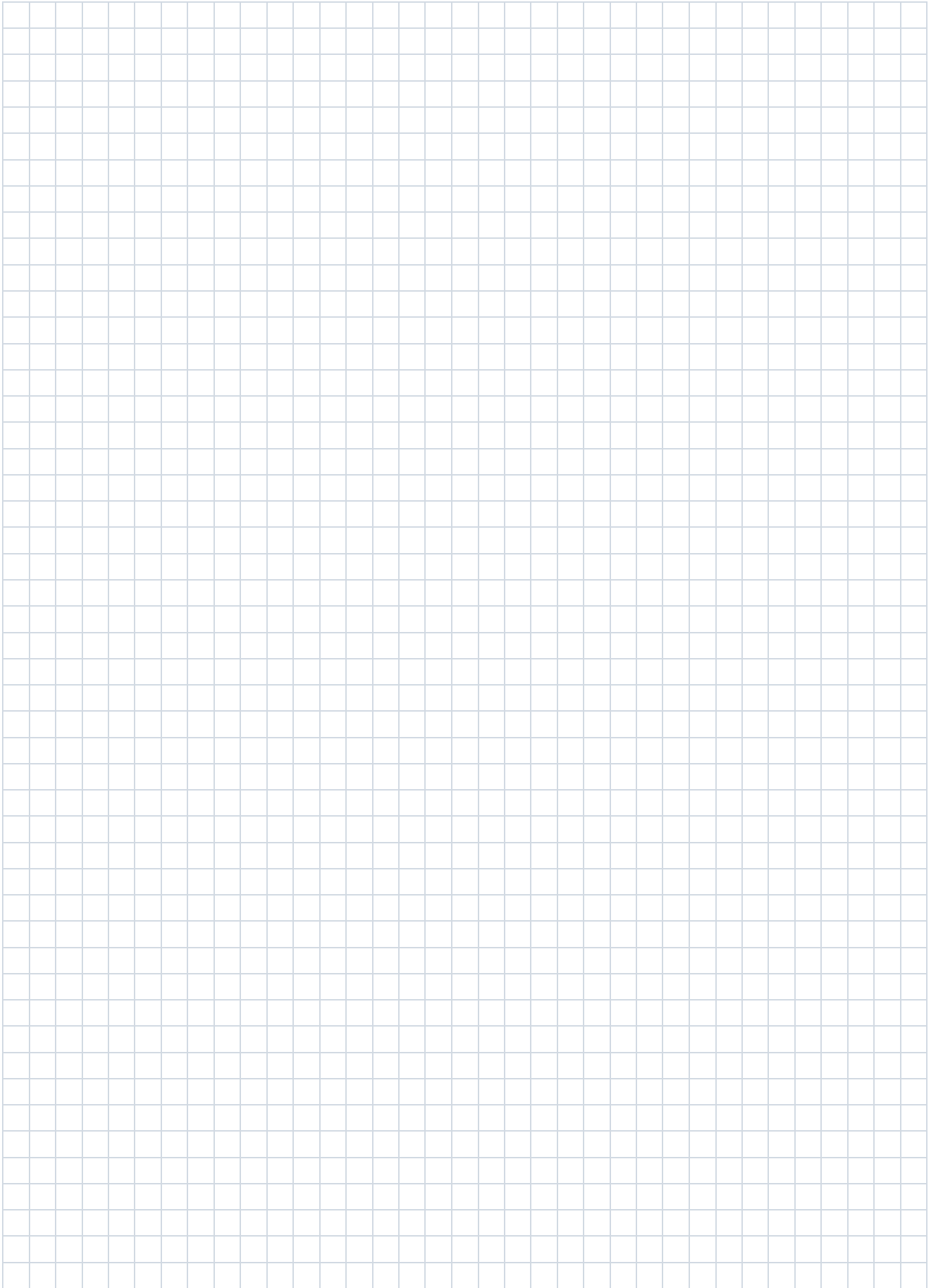

Edition 912907 (US) / 220718 (EU) 06/2011

Subject to modifications without notice

Pepperl+Fuchs Group  
www.pepperl-fuchs.com

USA: +1 330 486 0002  
pa-info@us.pepperl-fuchs.com

Germany: +49 621 776 2222  
pa-info@de.pepperl-fuchs.com

Copyright Pepperl+Fuchs  
Singapore: +65 6779 9091  
pa-info@sg.pepperl-fuchs.com



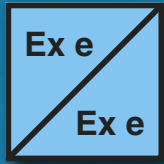

# Multi Function Terminal



Edition 912907 (US) / 220718 (EU) 05/2011

## Multi Function Terminal – more Power for Zone 1

Neither sparks nor hot surfaces may cause explosion hazards in areas where flammable gases, vapours, or mists may occasionally exist. Electrical apparatus for use in these areas must contain protection methods to prevent this.

In the past this meant that you had to obtain a hot work permit when you wanted to carry out maintenance work on these circuits. Alternatively the circuits would have to be intrinsically safe.

The new Multi Function Terminal employs a 2-step removal process to ensure that possible high energy sparks will be kept inside the flame proof enclosure of the terminals. The red removal lever of the terminals (see photo) separates the electrical circuits. The metal pins of the module remain within the flame proof area until the module is removed manually. At this point sparks will have been extinguished already and the module will be volt free.

## Multi Function Terminal MFT

294



- Hot swap in Zone 1 or Zone 2
- More power without hot work permits
- Many applications:  
fusing of Ex-d valves, signal lamps, sounders etc.
- Can be fitted with simple 2-pole or 4-pole components such as resistors, fuses, relays etc.
- Diode separation of supply circuits
- Simple OR gate for Zone 1 mounting
- Visible disconnect of field devices
- Relay switch for power circuits
- Bus termination
- Current limitation
- ATEX approved
- International approvals

Ex e  
Ex e

MFT

Products

Ex e  
Ex e

# Multi Function Terminal



Edition 912907 (US) / 220718 (EU) 05/2011

Subject to modifications without notice

294 Pepperl+Fuchs Group  
www.pepperl-fuchs.com

USA: +1 330 486 0002  
pa-info@us.pepperl-fuchs.com

Germany: +49 621 776 2222  
pa-info@de.pepperl-fuchs.com

Copyright Pepperl+Fuchs  
Singapore: +65 6779 9091  
pa-info@sg.pepperl-fuchs.com

**PEPPERL+FUCHS**  
PROTECTING YOUR PROCESS



**System Description** ..... 296

**Products**

**Selection Tables** ..... 297

**Product Data Sheets** ..... 298



MFT

Products

Edition 912907 (US) / 220718 (EU) 06/2011





Ex e  
Ex e

MFT

Products

Many applications in Zone 1 hazardous areas involve flame proof field devices which do not have intrinsically safe connections. In these cases increased safety protection methods are used. Unlike intrinsically safe loops increased safety connections are normally inaccessible while energized.

Disconnecting these loops for maintenance purposes therefore would either require the system to be powered down or a hot work permit.

The multi function terminal has been developed to overcome these obstacles. It employs a 2-step removal process to ensure that possible high energy sparks will be kept inside the flame proof enclosure of the terminals. The red removal lever of the terminals (see Figure 4) separates the electrical circuits. The metal contact pins of the module remain within a flame proof area until the module is removed manually.

At this point sparks which might have been generated within the flame proof area will have been extinguished already and the module will be volt-free.

The hot end terminals can be covered by plastic inserts to make sure they remain inaccessible.

The cold end will be accessible once the module has been removed. This will allow maintenance staff to exchange the connected apparatus while the rest of the equipment stays energized. This will lead to considerable time savings.

The multi function terminal MFT can be fitted with simple 2-pole or 4-pole components such as resistors, fuses, relays, diodes etc.

Typical applications are:

- fusing of Ex-d valves, signal lamps, sounders etc.
- diode separation of supply circuits
- simple OR gate for Zone 1 mounting
- visible disconnect of field devices
- relay switch for power circuits
- current limitation using resistors
- opto coupler applications etc.

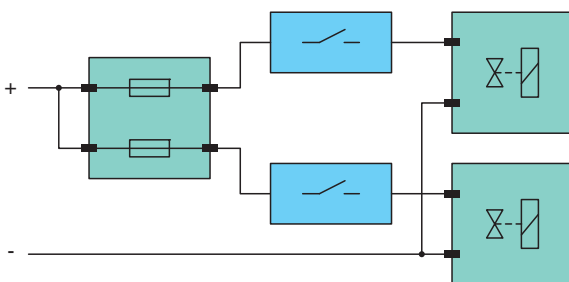

Figure 1 Example fuses protecting switched Ex-d valves

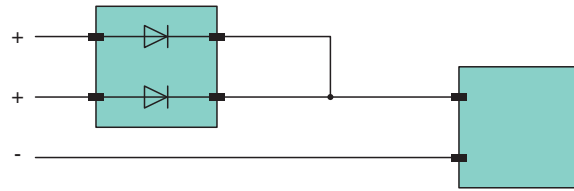

Figure 2 Example diodes allowing redundant power feed

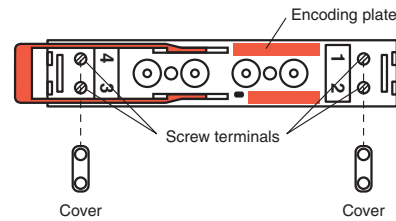

Figure 3 Top view base unit

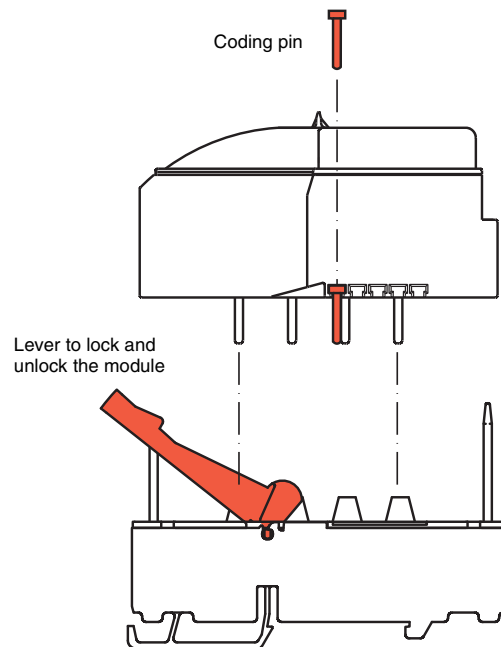

Figure 4 MFT with module removed

Multi Function Modules<sup>1</sup>

| Model Number | Function  |        |         |       |                         |    |    | Ambient Temperature |                  | Additional Requirements | Page |
|--------------|-----------|--------|---------|-------|-------------------------|----|----|---------------------|------------------|-------------------------|------|
|              | Resistors | Diodes | Jumpers | Fuses | Bus Terminator (PA, FF) | NO | NC | -20 °C ... 55 °C    | -20 °C ... 70 °C |                         |      |
| MFT-R.****   | 1         |        |         |       |                         |    |    |                     | ■                | max. 0.5 W              | 298  |
| MFT-2R.****  | 2         |        |         |       |                         |    |    | ■                   |                  |                         | 298  |
| MFT-D.1000   |           | 1      |         |       |                         |    |    | ■                   |                  | Diodes 230 V            | 298  |
| MFT-2D.0500  |           | 2      |         |       |                         |    |    | ■                   |                  | Diodes 230 V            | 298  |
| MFT-D.1000.L |           | 1      | 1       |       |                         |    |    | ■                   |                  | Diodes 230 V            | 298  |
| MFT-2L.****  |           |        | 2       |       |                         |    |    |                     | ■                |                         | 298  |
| MFT-F.****.L |           |        | 1       | 1     |                         |    |    | > 4 A               | max. 4 A         |                         | 298  |
| MFT-F.****   |           |        |         | 1     |                         |    |    | > 4 A               | max. 4 A         |                         | 298  |
| MFT-2F.****  |           |        |         | 2     |                         |    |    | ■                   |                  |                         | 298  |
| MFT-FT.0001  |           |        |         |       | ■                       |    |    |                     | ■                |                         | 298  |
| MFT-RNO.0006 |           |        |         |       |                         | ■  |    |                     | ■                | Relay 230 V             | 298  |
| MFT-RNC.0006 |           |        |         |       |                         |    | ■  |                     | ■                | Relay 230 V             | 298  |

<sup>1</sup> Sockets must be ordered separately.

## Sockets

| Model Number | 2-pole, 2-pin | 4-pole, 4-pin | Ambient Temperature<br>-20 °C ... 70 °C | Page |
|--------------|---------------|---------------|---|------|
|              |               |               |   |      |
| MFT-BASE.2P  | ■             |               | ■                                       | 298  |
| MFT-BASE.4P  |               | ■             | ■                                       | 298  |

Ex e  
Ex e

MFT

Products

**Features**

- Suitable for fusing solenoids, alarm indicators, sounders etc, and diode decoupling of power supplies
- Simple OR gate for zone 1 mounting, visible separation for field devices, relay switches
- Bus termination
- Current limiting
- DIN rail mounting
- Maintenance without hot work permit
- Wires can be disconnected during operation once the module has been removed (parts under voltage remain covered)

**Function**

The multi function terminal allows maintenance without a hot work permit in a hazardous area.

It employs a 2-step removal process which guarantees that a potentially formed ignition spark remains inside the flameproof enclosure when lifting off a module and thus makes sure that the ignition spark has extinguished and the module is volt-free.

**Technical data**

**Electrical specifications**

|                                 |  |
|---------------------------------|--|
| Resistor                        | 1 x 1 Ω ... 22 MΩ, 0.5 W<br>2 x 1 Ω ... 22 MΩ, 0.5 W |
| Diode                           | 1 x I ≤ 1 A<br>2 x I ≤ 0.5 A                         |
| Fuse                            | 0.032 ... 1.5 A<br>1.5 ... 6.3 A                     |
| Nominal voltage                 | 250 V, (≤ 400 V AC/DC on request)                    |
| Relay                           |  |
| Control                         | 24 V, approx. 5 ... 8.5 mA                           |
| Contact loading                 | AC ≤ 250 V, ≤ 6 A . DC ≤ 30 V, ≤ 1 A                 |
| Contact resistance              | 0.1 Ω at 6 V, 1 A                                    |
| Switching normally open contact | 5 x 10 <sup>4</sup>                                  |
| Switching rest contact          | 3 x 10 <sup>4</sup>                                  |

**Ambient conditions**

|                     |                                  |
|---------------------|----------------------------------|
| Ambient temperature | Details see ordering information |
|---------------------|----------------------------------|

**Mechanical specifications**

|                   |   |
|-------------------|---|
| Protection degree | IP20                                      |
| Mass              | approx. 115 g, depending on model         |
| Dimensions        | 80 x 93 x 17.5 mm (3.15 x 3.66 x 0.69 in) |

**Data for application in connection with Ex-areas**

|                                     |   |
|-------------------------------------|---|
| EC-Type Examination Certificate     | PTB 07 ATEX 1004 U                                |
| Group, category, type of protection | Ex II 2 G Ex de IIC                               |
| Directive conformity                |   |
| Directive 94/9/EC                   | EN 60079-0:2006, EN 60079-1:2004, EN 60079-7:2003 |

**Diagrams**

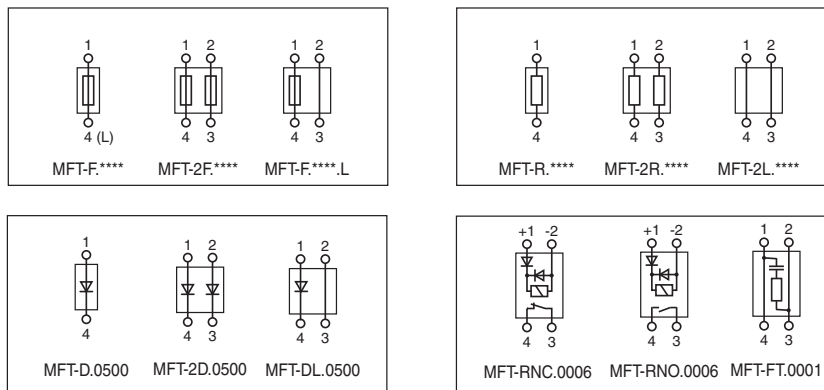

Edition 06/2011 912907 (US) / 220718 (EU)



MFT

Products

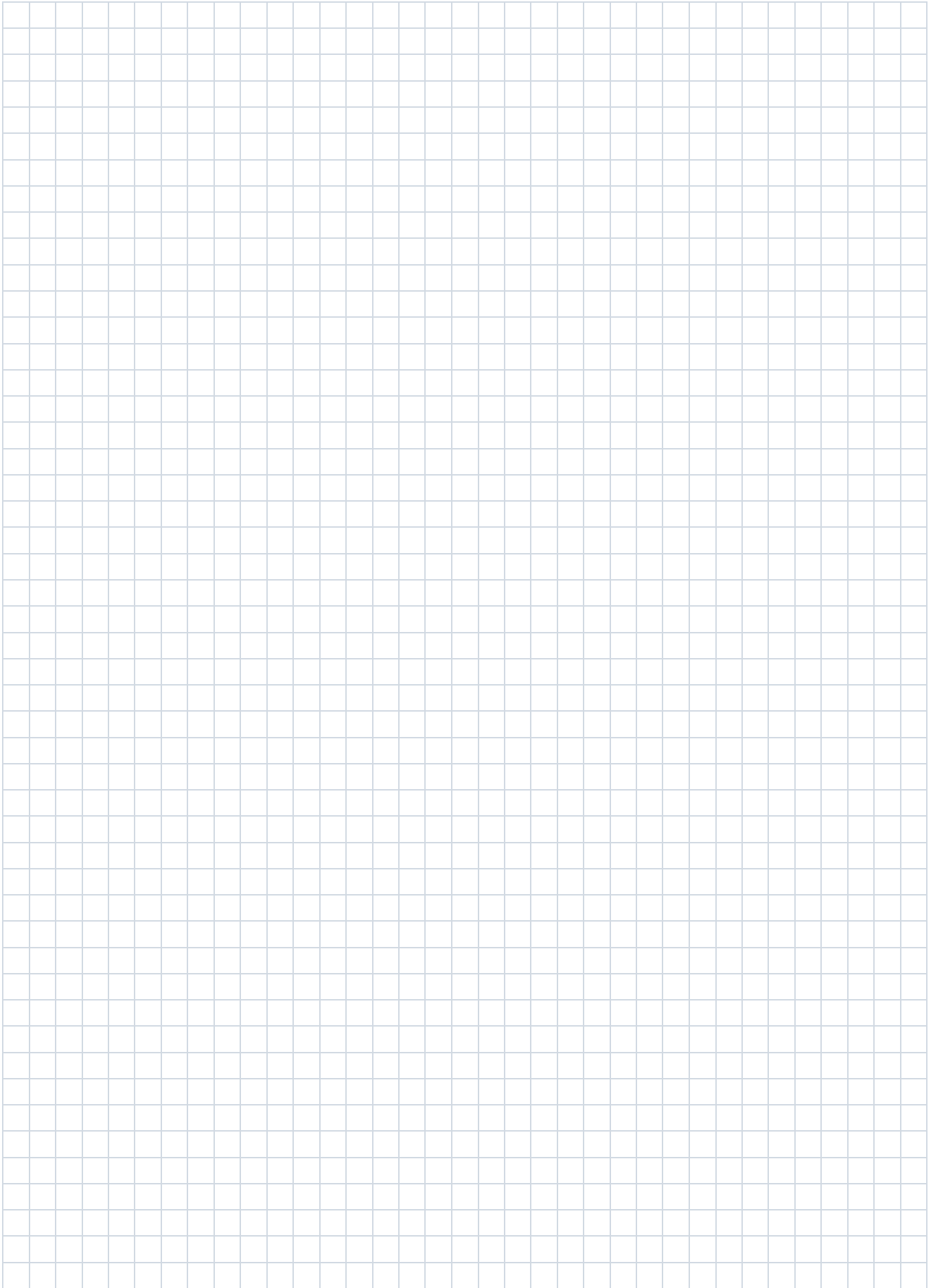

Edition 912907 (US) / 220718 (EU) 06/2011

Subject to modifications without notice

Pepperl+Fuchs Group  
www.pepperl-fuchs.com

USA: +1 330 486 0002  
pa-info@us.pepperl-fuchs.com

Germany: +49 621 776 2222  
pa-info@de.pepperl-fuchs.com

Copyright Pepperl+Fuchs  
Singapore: +65 6779 9091  
pa-info@sg.pepperl-fuchs.com

# Appendix

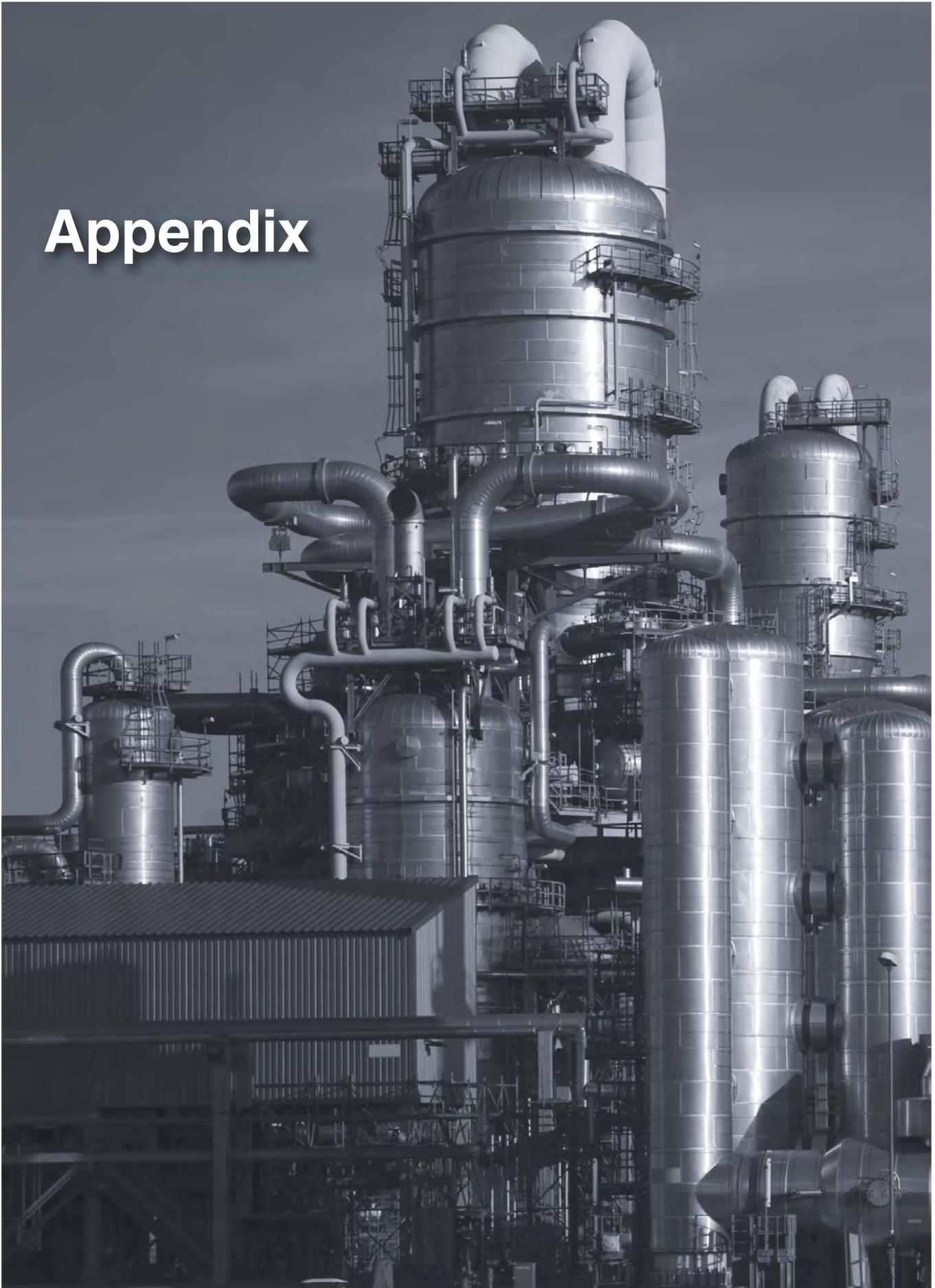

Edition 912907 (US) / 220718 (EU) 05/2011



**Glossary**..... 303

**Function Index** ..... 323

**Model Number Index**..... 333

Appendix

Glossary

Function Index

Model Number Index

Edition 912907 (US) / 220718 (EU) 06/2011



Appendix

Glossary

Function Index

Model Number Index

Edition 912907 (US) / 220718 (EU) 06/2011

## A

**Active Zener Barrier**

A zener barrier with additional active components (i. e., transistors, integrated circuits, etc.) that provides special functions or features.

**AIT**

Abbreviation for autogenous ignition temperature.

**Amplifier**

A device that enables an input signal to control power from a source independent of the signal and thus be capable of delivering an output that bears some relationship to, and is generally greater than, the input signal.

**Analog Input**

Analog type signal from a hazardous area instrument (i. e., transmitter) to the safe area controller.

**Analog Output**

Analog type signal from the safe area controller to the hazardous area instrument (i. e., I/P positioner).

**ANSI**

Acronym for American National Standards Institute.

**API**

Acronym for American Petroleum Institute.

**Approved**

Acceptable to the authority having jurisdiction.

**Arcing Device**

A device, such as make/ break component, that under normal conditions produces an arc with energy sufficient to cause ignition of an ignitable mixture. See also "non-incendive circuit."

**Asset Management**

Asset Management functionality often includes the monitoring of devices like flow meters, analyzers, actuators, and control valves. It detects faults and sometimes even recommends corrective actions.

**Associated Apparatus**

Apparatus in which the circuits are not necessarily intrinsically safe themselves, but which affect the energy in the intrinsically safe circuits and are relied upon to maintain intrinsic safety. Associated electrical apparatus may be either

1. electrical apparatus that have an alternative type of protection, for use in the appropriate hazardous (classified) location; or
2. electrical apparatus that are not protected and therefore cannot be used within a hazardous (classified) location.

**Associated Non-Incendive Field Wiring Apparatus**

Apparatus in which the circuits are not necessarily non-incendive themselves but that affect the energy in non-incendive field wiring circuits and are relied upon to maintain non-incendive energy levels.

**Associated Safe-Location Equipment**

Equipment designed to form part of an intrinsically safe system, in which not all the circuits are of an intrinsically safe system, in which not all the circuits are intrinsically safe, but which affects the safety of the intrinsically safe system of which it forms a part. Such equipment may not be installed in a hazardous location unless provided with appropriate protection, such as the installation of an explosion-proof enclosure in a Class I hazardous location. Examples of associated safe-location equipment are

1. a line-connected power unit supplying power to intrinsically safe equipment in a hazardous location and
2. a recorder in a safe location actuated by a transducer situated in a hazardous location.

**Authority Having Jurisdiction**

The organization, office, or individual that has the responsibility and authority for approving equipment, installations, or procedures.

**Autogenous Ignition Temperature**

The temperature at which a mixture of a specified gas or vapor in air will spontaneously ignite under specified test conditions, without any source of ignition.

**Automation System**

The system that provides overall control and monitoring functions of a specific process or application. Generally consists of a network of computers, controllers, and I/O modules.



## B

**Barrier Specification**

The typical way of describing a barrier, for example 28 V, 300  $\Omega$ , 93 mA. This is a reference to the maximum voltage of the terminating zener diode during the period of time it takes for the fuse to break, the minimum value of the terminating resistor and the resulting maximum short circuit current. The description does not refer to the working voltage or the end-to-end resistance, but is purely an indication of the potential fault energy that could be generated in the hazardous area.

**BASEEFA**

Acronym for British Approvals Service for Electrical Equipment in Flammable Atmospheres. A governmental body in the United Kingdom that has the authority to accept or reject the design of an electrical apparatus based on recognized safety standards.

**BSI**

Acronym for British Standards Institute.

**Bus Technology**

A variety of bus technologies are employed throughout the industry. PROFIBUS, MODBUS, FOUNDATION fieldbus, and Ethernet ensure reliable exchange of digital information between the control system and Remote I/O.

## C

**Capacitance**

The property of a system of conductors and dielectrics that permits the storage of electrically separated charges when potential differences exist between the conductors. The greater the capacitance, the greater the charge that can be stored. The practical difference between capacitance and inductance in an intrinsically safe circuit is minimal. Both store energy but a capacitor will release energy when a circuit is made and an inductor will release energy when the circuit is broken.

**CENELEC**

Acronym for European Electrotechnical Committee for Standardization. The standard for the European Economic Community (EEC) nations and the European Free Trade Association. Legally, certification to the CENELEC standard is sufficient to permit sale in any European country. If IEC standards are available, CENELEC tries to utilize them because these standards are already adopted by the European community.

**Certified Equipment**

Equipment that has been evaluated by a recognized testing agency and confirmed to be in compliance with the applicable standard(s).

**CESI**

Acronym for Centro Elettronico Sperimentale Italiano. A governmental body in Italy that has the authority to accept or reject the design of an electrical apparatus based on recognized safety standards.

**Class I Location**

A location in which flammable gases or vapors are or may be present in the air in quantities sufficient to produce explosive or ignitable mixtures.

**Class I, Division 1 Location**

A location (1) in which ignitable concentrations of flammable gases or vapors can exist under normal operating conditions; (2) in which ignitable concentrations of such gases or vapors may exist frequently because of repair or maintenance operations or because of leakage; or (3) in which breakdown or faulty operation of equipment or processes might release ignitable concentrations of flammable gases or vapors and might also cause simultaneous failure of electrical equipment that could act as a source of ignition.

**Class I, Division 2 Location**

A location (1) in which volatile flammable liquids or flammable gases are handled, processed, or used, but in which the liquids, vapors, or gases will normally be confined within closed containers or closed systems from which they can escape only in case of accidental rupture or breakdown of such containers or systems, or in case of abnormal operation of equipment; (2) in which ignitable concentrations of gases or vapors are normally prevented by positive mechanical ventilation and might become hazardous through failure or abnormal operation of the ventilating equipment; or (3) that is adjacent to a Class I, Division 1 location and to which ignitable concentrations of gases or vapors might occasionally be communicated unless such communication is prevented by adequate positive-pressure ventilation from a source of clean air and effective safeguards against ventilation failure are provided. Electrical conduits and their associated enclosures separated from process fluids by a single seal or barrier are classified as a Class I, Division 2 location if the outside of the conduit and enclosures is a non-hazardous (unclassified) location.

## Class II Location

A location that is hazardous because of the presence of combustible dust.

### Class II, Division 1 Location

A location (1) in which combustible dust is in the air under normal operating conditions in quantities sufficient to produce explosive or ignitable mixtures; (2) in which mechanical failure or abnormal operation of machinery or equipment might cause such explosive or ignitable mixtures to be produced and might also provide a source of ignition through simultaneous (the word "simultaneous" is not included in the Canadian definition) failure of electric equipment, operation of protection devices, or from other causes; or (3) in which combustible dusts of an electrically conductive nature may be present in hazardous quantities.

### Class II, Division 2 Location

A location in which combustible dust is not normally in the air in quantities sufficient to produce explosive or ignitable mixtures and dust accumulations are normally insufficient to interfere with the normal operation of electrical equipment or other apparatus, but combustible dust may be in suspension in the air as a result of infrequent malfunctioning of handling or processing equipment and where combustible dust accumulations on, in, or in the vicinity of the electrical or may be ignitable by abnormal operation or failure of electrical equipment.

## Class III Location

A location that is hazardous because of the presence of easily ignitable fibers or flyings but in which such fibers or flyings are not likely to be in suspension in the air in quantities sufficient to produce ignitable mixtures.

### Class III, Division 1 Location

A location in which easily ignitable fibers or materials producing flyings are handled, manufactured, or used.

### Class III, Division 2 Location

A location in which easily ignitable fibers are stored or handled (except in the process of manufacture).

## Clearance Distance

The shortest distance measured in air between conductive parts.

## Code of Practice

An international term referring to a document that describes basic safety features and methods of protection and recommends the selection, installation, and maintenance procedures that should be followed to ensure the safe use of electrical apparatus.

## Com Unit and Gateway

Bus systems employ communication units (Com Units) to interface the DCS or PLC master with the Remote I/O slaves. Their properties depend on the protocol they support.

## Configuration in Run (CiR or HCiR)

Online Remote I/O changes are made possible by means of (hot) configuration in run (HCiR) methods. This is based on freezing output data during the bus reset period or by offering redundant rings.

## Converter

A type of isolated barrier that receives a signal from the hazardous area instrument (i. e. transmitter, thermocouples, etc.) and converts it into an equivalent signal (i. e. 4 mA ... 20 mA, 1 V ... 5 V, etc.).

## Control Drawing

A drawing or other document provided by the manufacturer of the intrinsically safe or associated apparatus that details the allowed interconnections between the intrinsically safe and associated apparatus.

## CSA

Acronym for Canadian Standards Association. A third party certification agency headquartered in Canada and recognized by OSHA as a Nationally Recognized Test Laboratory in the United States. The presence of CSA, UL, or FM certification marks on equipment is normally sufficient to the local inspector that the product is designed to recognized safety standards.

## D

**Definition of Contamination Level 2 per EN 50178**

Under normal circumstances, only non-conductive contamination occurs. Occasionally however, short-term conductance may be expected through condensation when the device is not being operated. This applies to the immediate surrounding conditions of the electronic device.

**Device Type Manager (DTM)**

Manufacturers supply DTMs for their devices to allow a FDT frame application in the DCS or master to configure and service their equipment.

**Digital Input**

Signal from a hazardous area instrument that is an on/off type electrical input to the safe area (i. e., contact closure, proximity sensor).

**Digital Output**

On/Off type signal from the safe area to the hazardous area (i. e., signal to a solenoid or LED cluster).

**Distance Through Casting Compound**

The shortest distance between two conductive parts separated by a casting compound.

**Distance Through Solid Insulation**

The shortest distance between two conductive parts separated by solid insulation.

**Driver**

A type of active or transformer isolated barrier that receives a signal from a safe area source (i. e., DCS, process controller, etc.) and drives that signal to the hazardous area instrument (i. e., I/P positioner).

**Dust, Combustible**

Dust that (when mixed with air in certain proportions) can be ignited and will propagate a flame. The combustible properties of dust are dependent upon test conditions and dust particle size, chemical structure, and other particle characteristics.

**Dust-Ignition Proof**

A term used in the United States to describe an enclosure that will exclude ignitable amounts of dusts that might affect performance or rating and that, when installed and protected in accordance with the original design intent, will not permit arcs, sparks, or heat otherwise generated or liberated inside the enclosure to cause ignition of exterior accumulations or atmospheric suspensions of a specified dust.

**Dust-Protected Enclosure**

An international term describing an enclosure in which the ingress of dust is not totally prevented, but dust does not enter in sufficient quantity to interfere with the safe operation of the equipment or accumulate in a position within the enclosure where it is possible to cause an ignition hazard.

**Dust-Tight**

An enclosure so constructed that dust will not enter the enclosing case under specified test conditions.

## E

**EC-Type Examination Certificate**

The manufacturer certifies that the product meets the fundamental safety requirements under EC regulations by the application of a registration number to this product.

The following regulations apply to Pepperl+Fuchs products:

|            |  |
|------------|--|
| 73/23/EWG  | Low Voltage Directive                          |
| 89/336/EWG | EMC Directive                                  |
| 89/392/EWG | Machine Directive                              |
| 94/9/EG    | Devices and Safety Systems for Hazardous Areas |

**Encapsulation**

An international term describing a type of protection in which the parts that could ignite an explosive atmosphere by either sparking or heating are enclosed in an encapsulant in such a way that this explosive atmosphere cannot be ignited. This type of protection is referred to by GENELEC as "Ex m" in Standard EN 60079-18.

**End-to-End Resistance**

The resistance between both ends of a barrier channel. It is the sum of the resistor itself and the resistance of the fuse at an ambient temperature of 20 °C.

## Entity Concept

The entity concept provides more flexibility in selecting equipment to form an intrinsically safe system. The entity concept allows the user to identify acceptable combinations of intrinsically safe apparatus and associated apparatus that have not been examined as a system.

## Entity Parameters

The four categories that are set by the certification agency in order to properly match the intrinsic safety barrier to the hazardous area instrument. These four parameters are voltage, current, capacitance and inductance.

## Ethernet

High speed bus, which lends itself to various protocols. Most commonly used protocols are MODBUS TCP and Ethernet IP. Redundancy solutions are in place. Slaves are often connected to the bus via switches.

## Ex "d"

Designation for the flame-proof (explosion containment) method of protection.

## Ex "e"

Designation for the increased safety (prevention) method of protection.

## Ex "i"

Designation for the intrinsic safety (prevention) method of protection. This method consists of two categories-"ia" and "ib."

## Ex "ia"

This intrinsic safety category is limited to low power circuits and is suitable for process instrumentation. Up to two faults are allowed and can be used in Zones 0, 1, and 2.

## Ex "ib"

This intrinsic safety category is similar to the Ex "ia" method, except that category "ib" allows only one fault and can only be used in Zones 1 and 2.

## Ex "m"

Designation for the encapsulation (segregation) method of protection.

## Ex "n"

Designation for the simplified (prevention) method of protection.

## Ex "o"

Designation for the oil-immersion (segregation) method of protection.

## Ex "p"

Designation for the pressurization (segregation) method of protection.

## Ex "q"

Designation for the powder-filling (segregation) method of protection.

## Ex "s"

Designation for the special (special protection) method of protection. This method is standardized only in Great Britain and Germany.

## Explosion-Proof Enclosure

An enclosure that is capable of withstanding an explosion of a gas or vapor within it and of preventing the ignition of an explosive gas or vapor that may surround it and that operates at such an external temperature that a surrounding explosive gas or vapor will not be ignited. This type of enclosure is similar to a flame-proof enclosure.

## Explosion-Proof Equipment (apparatus)

Equipment or apparatus enclosed in an explosion-proof enclosure.

## F

### Fault

A defect or electrical breakdown of any component, spacing or insulation that alone or in combination with other faults may adversely affect the electrical or thermal characteristics of the intrinsically safe circuit. If a defect or breakdown leads to defects or breakdowns in other components, the primary and subsequent defects and breakdowns are considered to be a single fault.

#### Countable Fault

A fault that is applied to a part of the electrical apparatus that meets the constructional requirements of this standard.

#### Uncountable Fault

A fault that is applied to areas of the electrical apparatus that do not meet the constructional requirements of this standard. If application of a countable fault leads to subsequent defects and breakdowns, they are considered to be uncountable faults.

## Fibers and Flyings, Easily Ignitable

Fibers and flyings that are easily ignitable including rayon, cotton (including cotton linters and cotton waste), sisal or henequen, jute, hemp, tow, cocoa fiber, oakum, baled waste kapok, Spanish moss, excelsior, and other materials of similar nature.

## FieldConnex

FieldConnex is a comprehensive fieldbus infrastructure that connects the control system to intelligent field instruments via a two wire bus.

## Field Device Tool (FDT)

FDT is the name of an interface specification. It offers the frame application for DTM (drivers) supplied by device manufacturers.

## Flame-Proof Enclosure

An International term describing an enclosure that can withstand the pressure developed during an internal explosion of an explosive mixture and that prevents the transmission of the explosion to the explosive atmosphere surrounding the enclosure and that operates at such an external temperature that a surrounding explosive gas or vapor will not be ignited. This enclosure is similar to an explosion-proof enclosure. This type of protection is referred to by IEC as "Ex d."

## FM

Acronym for Factory Mutual Approvals, a third party certification agency that is recognized by OSHA as a Nationally Recognized Testing Laboratory in the United States. It is a division of Factory Mutual Global, which specializes in property insurance. For marketing in the U.S., FM, CSA, and UL provide testing, listing and labeling services for industrial and safety products. Generally, certifications by FM, CSA, and UL are recognized in most jurisdictions; however, there are exceptions.

## FOUNDATION Fieldbus

FOUNDATION fieldbus is a digital communications system that serves as the base-level network in a plant or factory automation environment. It is an open architecture, developed and administered by the Fieldbus Foundation.

Fieldbus permits the use of spurs and chicken foot structures based on IEC 61158-2 standards.

## Fuse Rating

This is the maximum current that can flow continuously through the fuse (approx. 1000 hours at 35 °C). The rated current may be exceeded for short periods at temperatures up to approximately 55 °C.

## Fuse-Protected Shunt Diode Barrier Assembly (Zener Barrier)

A network consisting of a fuse, voltage-limiting shunt diodes, and a current-limiting resistor or other current-limiting components designed to limit current and voltage. The fuse protects the diodes from open circuiting when high fault current flows.

## G

## Gateway and Com Unit

Bus systems employ gateways to interface the DCS or PLC master with the Remote I/O slaves. Their properties depend on the protocol they support.

## Galvanic Isolation

A form of isolation that meets stringent standards for intrinsically safe circuits.

## Grounding Device

An impedance device used to connect conductors of an electric system to ground for the purpose of controlling the ground current or voltages to ground, or a nonimpedance device used to temporarily ground conductors for the purpose of the safety of workmen. The grounding device may consist of a grounding transformer or a neutral grounding device, or a combination of these. Protective devices, such as surge arresters, may also be included as an integral part of the device.

## Group

A classification of flammable materials of similar hazard. Consists of Groups A, B, C, D, E, F, and G to NEC and CEC standards and Groups I, IIA, IIB, and IIC to IEC standards.

## H

**HART**

HART (**H**ighway **A**ddressable **R**emote **T**ransducer) is a popular digital fieldbus protocol that solves a wide range of applications. It is used to communicate with field devices, configure and monitor the status of the system, and indicate process variables.

**Hazardous (Classified) Location**

A location where fire or explosion hazards may exist due to the presence of flammable gases or vapors, flammable liquids, combustible dust, or easily ignitable fibers or flyings.

**Hazardous Materials**

Gases, vapors, combustible dusts, fibers, or flyings that are explosive under certain conditions.

**Hermetically Sealed Device**

A device that is sealed against the entrance of an external atmosphere and in which the seal is made by fusion. Continuous soldering, brazing, welding, and the fusion of glass to metal are examples of recognized methods.

## I

**I.S. Ground**

A dedicated ground system to which zener barriers are connected. The resistance to ground path must be less than or equal to 1  $\Omega$  from any zener barrier to designated ground electrode.

**I.S.**

Abbreviation for intrinsic safety.

**I/O Module**

A module that provides basic input and output functions between the automation system and the field devices. Disregarding specialty modules, there are four basic types available from various vendors - analog input, analog output, discrete input, and discrete output.

**IEC**

Acronym for International Electrotechnical Commission. An international commission of which most nations are members. IEC standards directly affect equipment for sale internationally. The benefit of participation in the IEC is that costly differences in plant or equipment design can be avoided by designing equipment consistent with IEC documents where feasible.

**Ignitable Gas Mixture**

A gas -air mixture that is capable of being ignited by an open flame, arc or spark or high temperature.

**Ignition (Autoignition) Temperature**

The minimum uniform temperature required to initiate or cause self-sustained combustion of a solid, liquid, or gaseous substance (independent of any other ignition source).

**Increased Safety**

An international term that describes a type of protection in which various measures are applied so as to reduce the probability of excessive temperatures and the occurrence of arcs or sparks in the interior and on the external parts of electrical apparatus that do not produce them in normal service. This type of protection is referred to by IEC as "Ex e."

**Inductance**

The property of an electric circuit by virtue of which a varying current induces an electromotive force in that circuit or in a neighboring circuit. The practical difference between capacitance and inductance in an intrinsically safe circuit is minimal. Both store energy, but an inductor will release energy when a circuit is broken, and a capacitor will release energy when the circuit is made.

**Insulation coordination**

The assignment of the insulation characteristics of an apparatus in accordance with:

1. the expected overvoltages
2. the characteristic values of the overvoltage precautions
3. the expected surrounding conditions
4. the protective measures against contamination

**Insulator**

A material that conducts electrons slowly. The importance to intrinsic safety is that air (a spatial distance) is often an insulator.

**Internal Wiring**

Wiring and electrical connections that are made within the apparatus by the manufacturer. Within racks or panels, interconnections between separate pieces of apparatus made in accordance with detailed instructions from the apparatus manufacturer are considered to be internal wiring.

## Intrinsic Safety Barrier

A component containing a network designed to limit the energy (voltage and current) available to the protected circuit in the hazardous (classified) location under specified fault conditions.

## Intrinsic Safety Ground Bus

A grounding system that has a dedicated conductor separate from the power system so that ground currents will not normally flow and that is reliably connected to a ground electrode (e. g., in accordance with Article 250 of NEC, ANSI/NFPA 70, or Section 10 of CEC Part I, CSA C22.1).

## Intrinsic Safety

A type of protection in which a portion of the electrical system contains only intrinsically safe equipment (apparatus, circuits, and wiring) that is incapable of causing ignition in the surrounding atmosphere. No single device or wiring is intrinsically safe by itself (except for battery-operated self-contained apparatus such as portable pagers, transceivers, gas detectors, etc., which are specifically designed as intrinsically safe self-contained devices) but is intrinsically safe only when employed in a properly designed intrinsically safe system. This type of protection is referred to by IEC as "Ex i."

## Intrinsically Safe Apparatus

Apparatus in which all the circuits are intrinsically safe.

## Intrinsically Safe Circuit

A circuit in which any spark or thermal effect, produced either normally or in specified fault conditions, is incapable, under the prescribed test conditions, of causing ignition of a mixture of flammable or combustible material in air in the mixture's most easily ignited concentration.

## Intrinsically Safe Equipment

Equipment that may be installed in a hazardous location, in which all the circuits are intrinsically safe, or that is designed to form part of an intrinsically safe system.

## Intrinsically Safe Ground

A clearly identified conductor of not less than 12 AWG/4 mm<sup>2</sup> cross-sectional area with a total impedance from barrier ground bus bar to main power system earth of not more than 1 Ω.

## Intrinsically Safe System

An assembly of interconnected intrinsically safe apparatus, associated apparatus, and interconnecting cables in which those parts of the system that may be used in hazardous (classified) locations are intrinsically safe circuits.

## ISA

Acronym for the Instrumentation, Systems and Automation Society. ISA Committee SP12, established in 1949, has been influential in establishing the recognition of intrinsic safety and non-incendive circuits in the NEC.

## Isolated Barriers

A type of barrier with additional active components and galvanic isolation to separate the hazardous area instrument from the safe area controller providing advantages over the traditional zener barrier.

## K

### Knock-Out

A portion of the wall of an enclosure so fashioned that it may be removed readily by a hammer, screwdriver, and pliers at the time of installation in order to provide a hole for the attachment of an auxiliary device or raceway, cable, or fitting.

## L

### Labeled Equipment

Equipment or materials, to which has been attached a label, symbol, or other identifying mark of an organization concerned with product evaluation, that may maintain periodic inspection of the production of labeled equipment or materials, and by whose labeling the manufacturer indicates compliance with appropriate standards or performance in a specified manner.

### LEL

Abbreviation for lower explosive limit (lower flammable limit).

### Life Cycle Management

The product life cycle ensures that products or compatible replacements are available to cover the life of an industrial plant.

### Listed

Equipment or materials, included in a list published by an organization concerned with product evaluation, that maintains periodic inspection of production of listed equipment or materials and whose listing states either that the equipment or materials meets appropriate standards or has been tested and found suitable for use in the specified manner.

## M

**Maintenance, Corrective**

Any maintenance activity that is not normal in the operation of the equipment and requires access to the equipment's interior. Such activities are expected to be performed by qualified personnel who are aware of the hazards involved. Such activities typically include locating causes of faulty performance, replacement of defective components, adjustment of internal controls, and the like.

**Maintenance, Operational**

Any maintenance activity, excluding corrective maintenance, intended to be performed by the operator and required in order for the equipment to serve its intended purpose. Such activities typically include the correcting of "zero" on a panel instrument, changing charts, record keeping, adding ink, and the like.

**Make/Break Components**

Components having contacts that can interrupt a circuit (even if the interruption is transient in nature). Examples of make/break components are relays, circuit breakers, servopotentiometers, adjustable resistors, switches, connectors, and motor brushes.

**Maximum External Capacitance ( $C_o$ ;  $C_a$ )**

Maximum capacitance in an intrinsically safe circuit that can be connected to the connection facilities of the apparatus without invalidating intrinsic safety.

**Maximum External Inductance ( $L_o$ ;  $L_a$ )**

Maximum value of inductance in an intrinsically safe circuit that can be connected to the connection facilities of the apparatus without invalidating intrinsic safety.

**Maximum External Inductance to Resistance Ratio ( $L_o/R_o$ )**

Ratio of inductance ( $L_o$ ) to resistance ( $R_o$ ) of any external circuit that can be connected to the connection facilities of the electrical apparatus without invalidating intrinsic safety.

**Maximum Inductance to Resistance Ratio ( $L/R$ )**

As an alternative value to  $L_a$ , the ratio of inductance ( $L$ ) to resistance ( $R$ ) of any external circuit that can be connected to the terminals of intrinsically safe apparatus without invalidating the intrinsic safety of the apparatus.

**Maximum Input Current ( $I_i$ ;  $I_{max}$ )**

Maximum current (peak AC or DC) that can be applied to the connection facilities for intrinsically safe circuits without invalidating intrinsic safety.

**Maximum Input Power ( $P_i$ )**

The maximum power that can be applied to the terminals of an intrinsically safe device without invalidating the intrinsic safety of the device.

**Maximum Input Voltage ( $U_i$ ;  $V_{max}$ )**

Maximum voltage (peak AC or DC) that can be applied to the connection facilities for intrinsically safe circuits without invalidating intrinsic safety.

**Maximum Internal Capacitance ( $C_i$ )**

The total unprotected internal capacitance of the intrinsically safe apparatus that must be considered as appearing across the terminals of the intrinsically safe apparatus.

**Maximum Internal Inductance ( $L_i$ )**

The total unprotected internal inductance of the intrinsically safe apparatus that must be considered as appearing across the terminals of the intrinsically safe apparatus.

**Maximum Internal Inductance to Resistance Ratio ( $L_i/R_i$ )**

Ratio of inductance ( $L_i$ ) to resistance ( $R_i$ ) which is considered as appearing at the external connection facilities of the electrical apparatus.

**Maximum Output Current ( $I_o$ ,  $I_{sc}$ )**

Maximum current (peak AC or DC) in an intrinsically safe circuit that can be taken from the connection facilities of the apparatus.

**Maximum Output Power ( $P_o$ )**

Maximum electrical power in an intrinsically safe circuit that can be taken from the apparatus.

**Maximum Output Voltage ( $U_o$ ,  $V_{oc}$ )**

Maximum output voltage (peak AC or DC) in an intrinsically safe circuit that can appear under open circuit conditions at the connection facilities of the apparatus at any applied voltage up to the maximum voltage, including  $U_m$  and  $U_i$ .



**Maximum r.m.s. AC or DC Voltage ( $U_m$ )**

Maximum voltage that can be applied to the non-intrinsically safe connection facilities of associated apparatus without invalidating intrinsic safety. The value of  $U_m$  may be different at different sets of connection facilities.

**Maximum Surface Temperature**

The highest temperature attained by a surface accessible to flammable gases, vapors, or combustible dusts under conditions of operation within the ratings of the apparatus (including recognized overloads and defined fault conditions).

**MEIC**

Abbreviation for most easily ignited concentration.

**MESG**

Abbreviation for maximum experimental safe gap.

**MIC**

Abbreviation for minimum ignition current.

**MIE**

Abbreviation for minimum ignition energy.

**Minimum Igniting Voltage**

Minimum voltage of capacitive circuits that causes the ignition of the explosive test mixture in the spark-test apparatus.

**MODBUS**

Legacy medium speed master/slave bus protocol based on RS485 hardware architecture. Offers easily understandable data address modes. Standard does not cover redundancy but individual solutions are in place. Slaves are connected to the bus in parallel.

**N****NEMA**

Acronym for National Electrical Manufacturers Association. Provides a rating system to identify an enclosure's ability to repel the outside environment. Unlike organizations such as UL, FM, and CSA, NEMA does not require independent testing and leaves compliance to its rating system completely up to the manufacturer.

**NFPA**

Acronym for National Fire Protection Association. The NFPA has acted as a sponsor and publisher of the National Electrical Code since 1911. Most of the NFPA standards tend to emphasize recommendations for the safe use of electrical apparatus, area classification, fire protection, and hazards of materials.

**Non-Hazardous Location**

A location utilizing drying, curing, or fusion apparatus and provided with positive mechanical ventilation adequate to prevent accumulation of flammable concentrations of vapors, and provided with effective interlocks to deenergize all electric equipment (other than equipment approved for Class I locations) in case the ventilating equipment is inoperative, shall be permitted to be classified as non-hazardous where the authority having jurisdiction so judges.

**Non-Incendive Circuit**

A circuit in which any arc or thermal effect produced in normal operating conditions of the equipment is not capable, under prescribed conditions, of igniting the specified flammable gas, vapor-in-air mixture, combustible dusts, or ignitable fibers or flyings.

**Non-Incendive Component**

A component having contacts for making or breaking a specified incendive circuit in which the contacting mechanism is constructed so that the component is not capable of ignition of the specified flammable gas or vapor-in-air mixture when tested as specified by appropriate test procedure. The housing of a non-incendive component is not intended to exclude the flammable atmosphere or contain an explosion.

**Non-Incendive Equipment**

Equipment having electrical/electronic circuitry and components that are incapable under normal conditions, of causing ignition of a specified flammable gas or vapor-in-air mixture due to arcing or thermal effect.

**Non-Incendive Field Wiring**

Wiring that enters or leaves an equipment enclosure and, under normal operating conditions of the equipment, is not capable, due to arcing or thermal effects, of igniting a specified flammable gas or vapor-in-air mixture or combustible dust-in-air mixture. Normal operation includes opening, shorting, or grounding the field wiring.

**Non-Incendive Field Wiring Apparatus**

Apparatus intended to be connected to non-incendive field wiring.

## Normal Operational Conditions

Conditions that conform electrically and mechanically with its design specifications and is used within the limits specified by the manufacturer.

## NRTL

Acronym for Nationally Recognized Testing Laboratory. This recognition indicates that the Occupational Safety & Health Administration has accredited certain organizations to evaluate products according to consensus based safety standards.

## O

### Operational Maintenance

Any maintenance activity, other than corrective maintenance, intended to be performed by the operators and which is required in order for the equipment to serve its intended purpose. Such activities typically include the correcting of "zero" on a panel instrument, changing charts, making records, adding ink, etc.

## OSHA

Acronym for Occupational Safety and Health Administration. The OSHA Act was passed by the U.S. Congress in 1971. Part 1910 of the OSHA regulations adopted the 1968 NEC and defined "approved" to mean "listed by UL or FM." "Approved" was redefined in 1972, providing exceptions to FM or UL listing; however, in practice the emphasis on listing remained unchanged. Listing requirements increased interest in developing standards for certain categories of apparatus, such as process control instrumentation. Third-party approval agencies (e. g., UL, FM, CSA) for electrical equipment must be accredited by OSHA.

### Overvoltage category

The assignment of an electrical apparatus in accordance with the expected overvoltage.

#### Table:

The assignment of rated operating voltages to the rated surge voltages

| Rated operating voltage (V) for alternating voltage systems in accordance with DIN IEC 38 | Rated surge voltages (V) for overvoltage category |      |      |       |
|---|---|------|------|-------|
|   | I   | II   | III  | IV    |
| 230/400/277/480 <sup>1)</sup>   | 1500  | 2500 | 4000 | 6000  |
| 400/690   | 2500  | 4000 | 6000 | 8000  |
| 1000  | 4000  | 6000 | 8000 | 12000 |

<sup>1)</sup> Rated operating voltage of 500 V is set.

Table 1

## P

### Passive Transistor Output

A transistor in which the emitter and collector are not connected to an internal power source. Only the base is connected so that it may be switched on and off. The emitter and collector may be connected to the customer's power source.

### Polarity

Zener barriers are available in polarized (DC) and non-polarized (AC) versions. Positive polarity types have the negative side of the circuit grounded, while negative polarity types have the positive side of the circuit grounded. Non-polarized barriers have zener diodes connected in inverse series pairs and can be used in both AC and DC circuits.

### PROFIBUS DP, DP V1

Widely popular master/slave bus protocol based on RS485 hardware architecture. Offers fast and deterministic data exchange. Standard also covers redundancy. Slaves are connected to the bus in parallel.

### Protective (Infallible) Component or Assembly

A component or assembly which is so unlikely to become defective in a manner that will lower the intrinsic safety of the circuit it may be considered not subject to fault when analysis or tests for intrinsic safety are made. Examples of this type of component or assembly are:

## PTB

Acronym for Physikalisch-Technische Bundesanstalt. An approval agency in Germany that has the authority to accept or reject the design of an electrical apparatus based on recognized safety standards.

## R

### Redundancy

Redundancy is used to ensure that a Remote I/O station can continue to work even when there is a fault in a master, in a bus line, in a communication unit, or in a power supply.

### Remote I/O

A system of intrinsically safe galvanically isolated input and output devices placed in various locations around a production plant. They provide a way to communicate effectively with modern DCS systems and proven legacy field devices. Remote I/O connect a wide range of digital and analog sensors and actuators to process control systems over a fieldbus. A variety of gateways are available to make use of different bus protocols.

**Repeater**

A type of active or transformer isolated barrier that receives a signal from the hazardous area instrument (i. e., transmitter, thermocouple, etc.) and repeats that signal into the safe area while providing Intrinsic Safety.

**Resistance Temperature Detector (RTD)**

A resistor made of some material for which the electrical resistivity is a known function of the temperature and that is intended for use with a resistance thermometer. It is usually in such a form that it can be placed in the region where the temperature is to be determined.

**Resistance**

That physical property of an element, device, branch, network or system that is the factor by which the mean-square conduction current must be multiplied to give the corresponding power lost by dissipation as heat or as other permanent radiation or loss of electromagnetic energy from the circuit.

**RS 232**

An EIA standard that specifies the electrical, mechanical, and functional characteristics for serial communications. Used in point-to-point applications.

**RS 485**

An EIA standard that specifies the electrical characteristics of a balanced-voltage digital interface. Used in multi-point applications.

**S****Safe Area**

A non-hazardous location.

**Seal, Cable, Explosionproof**

A cable terminator filled with compound and designed to contain an explosion in the enclosure to which it is attached or to minimize passage of flammable gases or vapors from one location to another. A conduit seal may also be used as a cable seal. This method differs from the international practice, which requires cable glands.

**Seal, Conduit, Explosionproof**

A sealed fitting, poured with a cement-like potting compound, designed to contain an explosion in the enclosure to which it is attached and to minimize passage of flammable gases or vapors from one location to another.

**Serial Interface**

A method of digitally transmitting data between devices over a pair of conductors. See RS 232 and RS 485.

**Short Circuit Proof**

The ability of an intrinsic safety barrier or isolator to withstand the shorting of its' intrinsically safe connections to ground. Determined by dividing the rated voltage by its' internal resistance. If the resulting value is less than the fuse rating, the barrier is said to be short circuit proof.

**Short Circuit Protection**

The ability of the solid-state output to withstand a direct short without damage to itself.

**Shunt Diode Barrier Assembly**

A fuse- or resistor- protected diode barrier.

**Signal Conditioning**

Signal conditioning is an important part of any automation system where electrical isolation, electronic signal conversion, and measurement accuracy are critical characteristics of the control loop architecture. This is one of the tasks Remote I/O fulfill.

**Simple Apparatus**

An electrical component or combination of components of simple construction with well-defined electrical parameters that is compatible with the intrinsic safety of the circuit in which it is used. A device that will neither generate nor store more than 1.5 V, 0.1 A and 25 mW. Examples are switches, thermocouples (TCs), light-emitting diodes (LEDs), and resistance temperature devices (RTDs).

**SIT**

Abbreviation for spontaneous ignition temperature.

**Switch Isolator**

Term used for the type of transformer isolated barrier that is used to repeat signals from discrete inputs (i. e., contact closures, proximity sensors.)

**System Integration**

System integration forms a vital part of Remote I/O technology. The user can configure both the Remote I/O and the field devices from the system's own workstation or a secondary central operating console.

## T

**Temperature Code (Temperature Classification)**

A system of classification by which one of 14 temperature identification numbers (internationally, six temperature classes) is allocated to an electrical apparatus. The temperature code represents the maximum surface temperature of any component that may come in contact with the flammable gas or vapor mixture.

**Termination Panel**

A mechanical assembly that resides in front of the I/O system and performs signal conditioning, electrical isolation, and other functions.

**Thermistor**

An electron device that makes use of the change of resistivity of a semiconductor with change in temperature.

**Thermocouple (TC)**

A pair of dissimilar conductors so joined at two points that an electromotive force is developed by the thermoelectric effects when the junctions are at different temperatures.

**TIB**

Acronym for Transformer Isolated Barrier. A term used to describe an isolated intrinsic safety barrier used for hazardous area applications. Although a typical TIB will employ multiple means of isolation, the term TIB is used to generically describe this type of barrier.

**Transmitter (Tx)**

A device for transmitting a coded signal when operated by any one of a group of actuating devices.

## U

**UEL**

Abbreviation for upper explosive limit (upper flammable limit).

**UL**

Acronym for Underwriters Laboratories, Inc, a third party certification agency that is an independent, self-supporting, nonprofit testing laboratory and standards developer. It is recognized by OSHA as a Nationally Recognized Testing Laboratory in the United States. The presence of UL, CSA, or FM certification labels on equipment is normally sufficient evidence to the local inspector that the product is designed to meet recognized safety standards.

## Z

**Zener Barrier**

A combination of components that limits energy to the hazardous area to a level below that which would ignite a specific gas/air mixture.

**Zener Diode**

A class of silicon diodes that exhibit in the avalanche breakdown region a large change in reverse current over a very narrow range of reverse voltage. This characteristic permits a highly stable reference voltage to be maintained across the diode despite a relatively wide range of current through the diode.

**Zone**

The international method of specifying the probability that a location is made hazardous by the presence, or potential presence, of flammable concentrations of gases and vapors. The term Division is used in the United States and Canada.

**Zone 0**

An area in which an explosive gas-air mixture is continuously present or present for long periods. Equal to a Class I, Division 1 hazardous location.

**Zone 1**

An area in which an explosive gas-air mixture is likely to occur in normal operation. Equal to a Class I, Division 1 hazardous location.

**Zone 2**

An area in which an explosive gas-air mixture is not likely to occur and if it does occur, will only exist for a short time. Equal to a Class I, Division 2 hazardous location.

**Zone 20**

An area in which a combustible dust cloud is part of the air permanently, over long periods of time or frequently. Equal to a Class II, Division 1 hazardous location.

**Zone 21**

An area in which a combustible dust cloud in air is likely to occur in normal operation. Equal to a Class II, Division 1 hazardous location.

**Zone 22**

An area in which a combustible dust cloud in air may occur briefly or during abnormal operation. Equal to a Class II, Division 2 hazardous location.



Edition 912907 (US) / 220718 (EU) 06/2011

Subject to modifications without notice

Pepperl+Fuchs Group  
www.pepperl-fuchs.com

USA: +1 330 486 0002  
pa-info@us.pepperl-fuchs.com

Germany: +49 621 776 2222  
pa-info@de.pepperl-fuchs.com

Copyright Pepperl+Fuchs  
Singapore: +65 6779 9091  
pa-info@sg.pepperl-fuchs.com









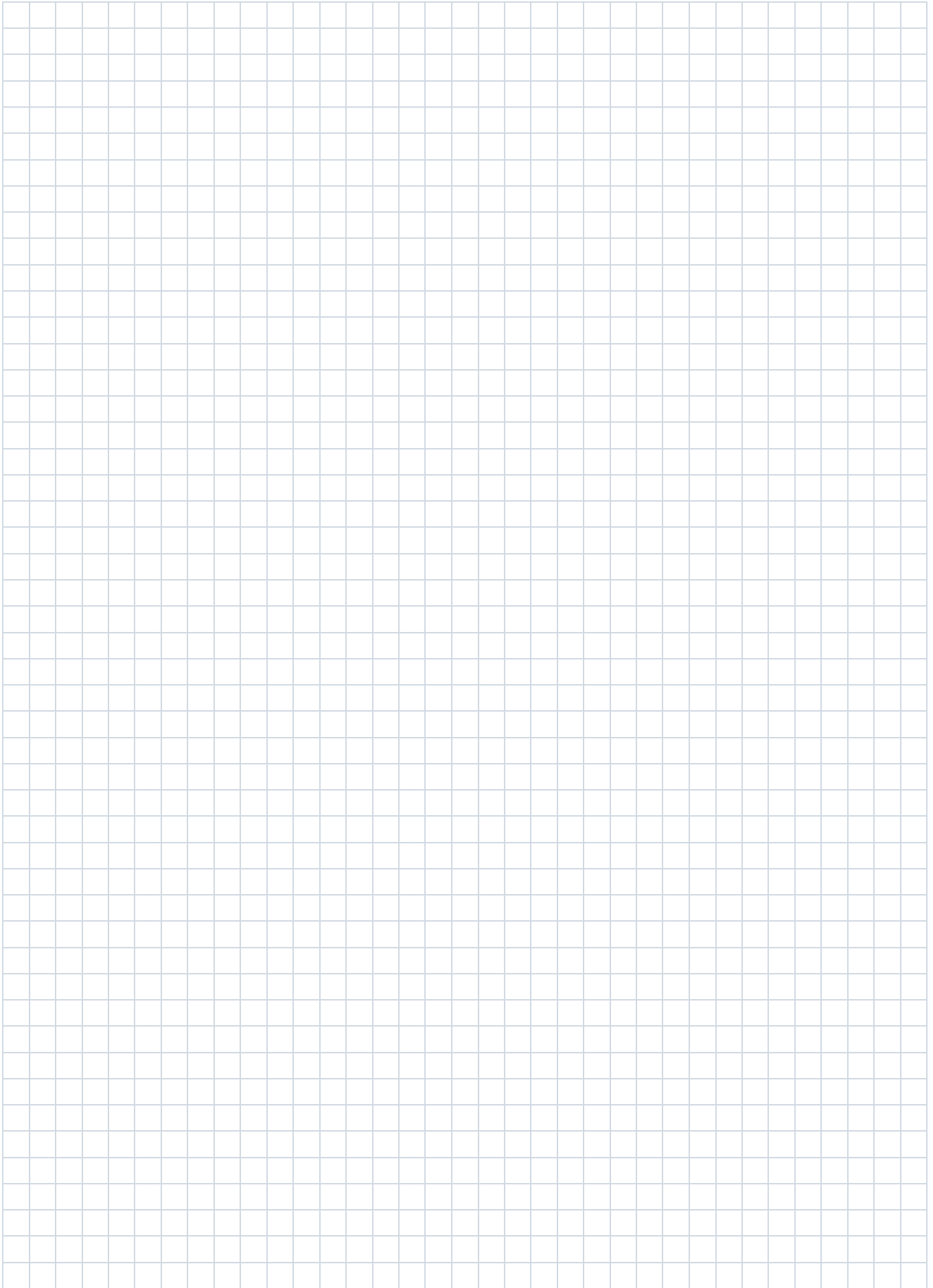

Edition 912907 (US) / 220718 (EU) 06/2011

Subject to modifications without notice

Pepperl+Fuchs Group  
www.pepperl-fuchs.com

USA: +1 330 486 0002  
pa-info@us.pepperl-fuchs.com

Germany: +49 621 776 2222  
pa-info@de.pepperl-fuchs.com

Copyright Pepperl+Fuchs  
Singapore: +65 6779 9091  
pa-info@sg.pepperl-fuchs.com





## Digital Inputs

| Model Number | Input |       |      | Mounting in        |        |   | Page |
|--------------|-------|-------|------|--------------------|--------|---|------|
|              | Ex ia | Ex ic | Ex e | Zone 2 and Zone 22 | Div. 2 | Suitable Enclosures in Zone 1 and Zone 21 |      |
| LB 1001 A    |       | ■     |      | ■                  |        |   | 112  |
| LB 1002 A    |       | ■     |      | ■                  |        |   | 113  |
| LB 1003 *    |       | ■     |      | ■                  |        |   | 114  |
| LB 1008 A    |       | ■     |      | ■                  |        |   | 115  |
| LB 1015 A    |       |       |      | ■                  |        |   | 116  |
| LB 1101 A    | ■     |       |      | ■                  | ■      |   | 117  |
| LB 1102 A    | ■     |       |      | ■                  | ■      |   | 118  |
| LB 1103 *    | ■     |       |      | ■                  | ■      |   | 119  |
| LB 1108 A    | ■     |       |      | ■                  | ■      |   | 120  |
| FB 1201 B    | ■     |       |      |                    |        | ■   | 202  |
| FB 1202 B    | ■     |       |      |                    |        | ■   | 203  |
| FB 1203 *    | ■     |       |      |                    |        | ■   | 204  |
| FB 1208 B    | ■     |       |      |                    |        | ■   | 205  |
| FB 1301 **   |       |       | ■    |                    |        | ■   | 206  |
| FB 1302 **   |       |       | ■    |                    |        | ■   | 207  |
| FB 1303 **   |       |       | ■    |                    |        | ■   | 208  |
| FB 1308 **   |       |       | ■    |                    |        | ■   | 209  |

Appendix

Glossary

Function Index

Model Number Index

Digital Outputs

| Model Number           | Input |       | Output |       |       |      | Mounting in |                    |        | Page |   |
|------------------------|-------|-------|--------|-------|-------|------|-------------|--------------------|--------|------|---|
|                        | Ex ia | Ex ic | Ex ia  | Ex ib | Ex ic | Ex e | Ex nA       | Zone 2 and Zone 22 | Div. 2 |      | Suitable Enclosures in Zone 1 and Zone 21 |
| LB 2002 *              |       | ■     |        |       | ■     |      |             | ■                  |        |      | 124                                       |
| LB 2101 - LB 2113      | ■     |       | ■      |       |       |      |             | ■                  | ■      |      | 125                                       |
| LB 2101 - LB 2113 SIL2 | ■     |       | ■      |       |       |      |             | ■                  | ■      |      | 126                                       |
| LB 6005 A              |       |       |        |       |       |      | ■           | ■                  |        |      | 127                                       |
| LB 6006 A              |       |       |        |       |       |      | ■           | ■                  |        |      | 128                                       |
| LB 6008 *              |       |       |        |       | ■     |      |             | ■                  |        |      | 129                                       |
| LB 6010 A              |       |       |        |       | ■     |      |             | ■                  |        |      | 130                                       |
| LB 6010 SIL2           |       |       |        |       | ■     |      |             | ■                  |        |      | 131                                       |
| LB 6101 H              |       |       |        |       |       |      | ■           | ■                  |        |      | 132                                       |
| LB 6108 *              |       |       |        | ■     |       |      |             | ■                  | ■      |      | 133                                       |
| LB 6110 - LB 6115      |       |       | ■      |       |       |      |             | ■                  | ■      |      | 134                                       |
| LB 6110 - LB 6115 SIL2 |       |       | ■      |       |       |      |             | ■                  | ■      |      | 135                                       |
| FB 2201 - FB 2213      | ■     |       | ■      |       |       |      |             |                    |        | ■    | 212                                       |
| FB 2201 - FB 2213 SIL2 | ■     |       | ■      |       |       |      |             |                    |        | ■    | 213                                       |
| FB 6208 *              |       |       |        | ■     |       |      |             |                    |        | ■    | 214                                       |
| FB 6210 - FB 6215      |       |       | ■      |       |       |      |             |                    |        | ■    | 215                                       |
| FB 6210 - FB 6215 SIL2 |       |       | ■      |       |       |      |             |                    |        | ■    | 216                                       |
| FB 6301 **             |       |       |        |       |       | ■    |             |                    |        | ■    | 217                                       |
| FB 6305 **             |       |       |        |       |       | ■    |             |                    |        | ■    | 218                                       |
| FB 6306 **             |       |       |        |       |       | ■    |             |                    |        | ■    | 219                                       |

Appendix

Glossary

Function Index

Model Number Index

Edition 912907 (US) / 220718 (EU) 06/2011

## Analog Inputs

| Model Number | Input |       |      | Mounting in        |        |   | Page |
|--------------|-------|-------|------|--------------------|--------|---|------|
|              | Ex ia | Ex ic | Ex e | Zone 2 and Zone 22 | Div. 2 | Suitable Enclosures in Zone 1 and Zone 21 |      |
| LB 3002 A    |       | ■     |      | ■                  |        |   | 138  |
| LB 3005 A    |       | ■     |      | ■                  |        |   | 139  |
| LB 3102 A    | ■     |       |      | ■                  | ■      |   | 140  |
| LB 3105 A    | ■     |       |      | ■                  | ■      |   | 141  |
| LB 5004 A    |       | ■     |      | ■                  |        |   | 142  |
| LB 5005 A    |       | ■     |      | ■                  |        |   | 143  |
| LB 5101 A    | ■     |       |      | ■                  | ■      |   | 144  |
| LB 5102 A    | ■     |       |      | ■                  | ■      |   | 145  |
| LB 5104 A    | ■     |       |      | ■                  | ■      |   | 146  |
| LB 5105 A    | ■     |       |      | ■                  | ■      |   | 147  |
| LB 5106 A    | ■     |       |      | ■                  | ■      |   | 148  |
| FB 3202 B    | ■     |       |      |                    |        | ■   | 222  |
| FB 3205 B    | ■     |       |      |                    |        | ■   | 223  |
| FB 3302 **   |       |       | ■    |                    |        | ■   | 224  |
| FB 3305 **   |       |       | ■    |                    |        | ■   | 225  |
| FB 5201 B    | ■     |       |      |                    |        | ■   | 226  |
| FB 5202 B    | ■     |       |      |                    |        | ■   | 227  |
| FB 5204 B    | ■     |       |      |                    |        | ■   | 228  |
| FB 5205 B    | ■     |       |      |                    |        | ■   | 229  |
| FB 5206 B    | ■     |       |      |                    |        | ■   | 230  |

## Analog Outputs

| Model Number | Output |       |      | Mounting in        |        |   | Page |
|--------------|--------|-------|------|--------------------|--------|---|------|
|              | Ex ia  | Ex ic | Ex e | Zone 2 and Zone 22 | Div. 2 | Suitable Enclosures in Zone 1 and Zone 21 |      |
| LB 4002 A    |        | ■     |      | ■                  |        |   | 152  |
| LB 4005 D    |        | ■     |      | ■                  |        |   | 153  |
| LB 4102 A    | ■      |       |      | ■                  | ■      |   | 154  |
| LB 4102 C    | ■      |       |      | ■                  | ■      |   | 155  |
| LB 4105 C    | ■      |       |      | ■                  | ■      |   | 156  |
| LB 4105 D    | ■      |       |      | ■                  | ■      |   | 157  |
| FB 4202 B    | ■      |       |      |                    |        | ■   | 234  |
| FB 4202 C    | ■      |       |      |                    |        | ■   | 235  |
| FB 4205 C    | ■      |       |      |                    |        | ■   | 236  |
| FB 4205 D    | ■      |       |      |                    |        | ■   | 237  |
| FB 4302 B    |        |       | ■    |                    |        | ■   | 238  |
| FB 4302 C    |        |       | ■    |                    |        | ■   | 239  |
| FB 4305 C    |        |       | ■    |                    |        | ■   | 240  |
| FB 4305 D    |        |       | ■    |                    |        | ■   | 241  |

Appendix

Glossary

Function Index

Model Number Index

## Bus Couplers

| Model Number | Fieldbus Type  |            |            |             |                      | Configuration |             |            | Mounting in                  |   | Page     |
|--------------|----------------|------------|------------|-------------|----------------------|---------------|-------------|------------|------------------------------|---|----------|
|              | PROFIBUS DP V1 | MODBUS RTU | MODBUS TCP | Fieldbus H1 | Service Bus (Option) | via GSD only  | via FDT 1.2 | via System | Zone 2 and Zone 22 or Div. 2 | Suitable Enclosures in Zone 1 and Zone 21 |          |
| LB 8106 H*** | ■              |            |            |             | ■                    | ■             |             | ■          | ■                            |   | 160      |
| LB 8107 H*** |                | ■          |            |             | ■                    |               | ■           |            | ■                            |   | 161      |
| LB 8109 H*** | ■              |            |            |             | ■                    |               | ■           | □          | ■                            |   | 162      |
| LB 8110 H*** |                |            |            | ■           | ■                    |               |             | ■          | ■                            |   | 163, 276 |
| LB 8111 A    |                |            | ■          |             | ■                    |               | ■           | □          | ■                            |   | 164      |
| FB 8206 H*** | ■              |            |            |             | ■                    | ■             |             | ■          |                              | ■   | 244      |
| FB 8207 H*** |                | ■          |            |             | ■                    |               | ■           |            |                              | ■   | 245      |
| FB 8209 H*** | ■              |            |            |             | ■                    |               | ■           | □          |                              | ■   | 246      |
| FB 8210 H*** |                |            |            | ■           | ■                    |               |             | ■          |                              | ■   | 247, 277 |
| FB 8211 A    |                |            | ■          |             |                      |               | ■           | □          |                              | ■   | 248      |

- depending on DCS  
 ■ available

## Power Supplies

| Model Number | Supply  |          |          | Redundant Supply Possible | Mounting in                  |   | Page |
|--------------|---------|----------|----------|---------------------------|------------------------------|---|------|
|              | 24 V DC | 115 V AC | 230 V AC |                           | Zone 2 and Zone 22 or Div. 2 | Suitable Enclosures in Zone 1 and Zone 21 |      |
| LB 9006 C    | ■       |          |          | ■                         | ■                            |   | 166  |
| FB 9205 C    |         |          | ■        | ■                         |                              | ■   | 250  |
| FB 9206 D    | ■       |          |          | ■                         |                              | ■   | 251  |
| FB 9215 B    |         |          | ■        |                           |                              | ■   | 252  |
| FB 9216 B    |         | ■        |          |                           |                              | ■   | 252  |



## Backplanes

| Model Number | Fieldbus Type |                |            |               |                        |                              | Mounting in        |        | Page     |
|--------------|---------------|----------------|------------|---------------|------------------------|------------------------------|--------------------|--------|----------|
|              | PROFIBUS DP   | PROFIBUS DP V1 | MODBUS RTU | MODBUS TCP/IP | FOUNDATION Fieldbus H1 | Determined by Base Backplane | Zone 2 and Zone 22 | Div. 2 |          |
| LB 9022 A    | ■             | ■              | ■          |               |                        |                              | ■                  | ■      | 174      |
| LB 9022 E    |               |                |            | ■             |                        |                              | ■                  | ■      | 175      |
| LB 9022 S    | ■             | ■              | ■          |               |                        |                              | ■                  | ■      | 177      |
| LB 9023 A    | ■             | ■              | ■          |               |                        |                              | ■                  | ■      | 179      |
| LB 9024 A    |               |                |            |               |                        | ■                            | ■                  | ■      | 176      |
| LB 9024 S    |               |                |            |               |                        | ■                            | ■                  | ■      | 178      |
| LB 9025 A    |               |                |            |               |                        | ■                            | ■                  | ■      | 180      |
| LB 9026 A    | ■             | ■              | ■          |               |                        |                              | ■                  | ■      | 181      |
| LB 9027 A    |               |                |            |               |                        | ■                            | ■                  | ■      | 182      |
| LB 9029 A    | ■             | ■              | ■          |               |                        |                              | ■                  | ■      | 183      |
| LB 9035 A    |               |                |            |               | ■                      |                              | ■                  | ■      | 184, 280 |

## Field Units (Enclosures)

| Model Number          | Material        |                 | Fieldbus Type |                |            |               |                        | Mounting in                  |                    | Page     |
|-----------------------|-----------------|-----------------|---------------|----------------|------------|---------------|------------------------|------------------------------|--------------------|----------|
|                       | Stainless Steel | Polyester (GRP) | PROFIBUS DP   | PROFIBUS DP V1 | MODBUS RTU | MODBUS TCP/IP | FOUNDATION Fieldbus H1 | Zone 2 and Zone 22 or Div. 2 | Zone 1 and Zone 21 |          |
| LB 9508-S92-0-0-1-0-0 | ■               |                 | ■             | ■              | ■          |               |                        | ■                            |                    | 185      |
| LB 9510-S90-0-0-1-0-F | ■               |                 |               |                |            |               | ■                      | ■                            |                    | 186, 281 |
| LB 9513-PB0-0-0-1-0-0 |                 | ■               | ■             | ■              | ■          |               |                        | ■                            |                    | 187      |
| LB 9516-PB0-0-0-1-0-0 |                 | ■               | ■             | ■              | ■          |               |                        | ■                            |                    | 188      |
| LB 9547-S70-0-0-1-0-M | ■               |                 |               |                |            | ■             |                        | ■                            |                    | 189      |
| LB 9547-S70-0-0-1-0-0 | ■               |                 | ■             | ■              | ■          |               |                        | ■                            |                    | 190      |
| FB 9210-PB0-0-0-0-0-F |                 | ■               |               |                |            |               | ■                      |                              | ■                  | 258, 282 |
| FB 9210-PB0-0-0-0-0-0 |                 | ■               | ■             | ■              | ■          |               |                        |                              | ■                  | 259      |
| FB 9224-PG0-0-0-0-0-0 |                 | ■               | ■             | ■              | ■          |               |                        |                              | ■                  | 260      |
| FB 9224-PH0-0-0-0-0-0 |                 | ■               | ■             | ■              | ■          |               |                        |                              | ■                  | 261      |
| FB 9248-PG0-0-0-0-0-0 |                 | ■               | ■             | ■              | ■          |               |                        |                              | ■                  | 262      |
| FB 9248-S70-0-0-0-0-0 | ■               |                 | ■             | ■              | ■          |               |                        |                              | ■                  | 263      |
| FB 9249-PG0-0-0-0-0-0 |                 | ■               | ■             | ■              | ■          |               |                        |                              | ■                  | 264      |
| FB 9249-S80-0-0-0-0-0 | ■               |                 | ■             | ■              | ■          |               |                        |                              | ■                  | 265      |

Edition 912907 (US) / 220718 (EU) 06/2011

## Fibre Optic Links

| Model Number   | PROFIBUS Interface | Automatic Baud Rate Detection | Star, Ring, or Line Topology Selectable | Mounting Options |                    |                            | Page |
|----------------|--------------------|-------------------------------|---|------------------|--------------------|----------------------------|------|
|                |                    |                               |   | on DIN Rail      | in Plastic Housing | in Stainless Steel Housing |      |
| FOL 7250 B 059 | ■                  | ■                             | ■                                       | ■                |                    |                            | 290  |
| FOL 7250 B 159 | ■                  | ■                             | ■                                       |                  | ■                  |                            | 290  |
| FOL 7250 B 259 | ■                  | ■                             | ■                                       |                  |                    | ■                          | 290  |

## Multi Function Terminals

### Multi Function Modules<sup>1</sup>

| Model Number | Function  |        |         |       |                         |    |    | Ambient Temperature |               | Additional Requirements | Page |
|--------------|-----------|--------|---------|-------|-------------------------|----|----|---------------------|---------------|-------------------------|------|
|              | Resistors | Diodes | Jumpers | Fuses | Bus Terminator (PA, FF) | NO | NC | -20 ... 55 °C       | -20 ... 70 °C |                         |      |
| MFT-R.****   | 1         |        |         |       |                         |    |    |                     | ■             | max. 0.5 W              | 298  |
| MFT-2R.****  | 2         |        |         |       |                         |    |    | ■                   |               |                         | 298  |
| MFT-D.1000   |           | 1      |         |       |                         |    |    | ■                   |               | Diodes 230 V            | 298  |
| MFT-2D.0500  |           | 2      |         |       |                         |    |    | ■                   |               | Diodes 230 V            | 298  |
| MFT-D.1000.L |           | 1      | 1       |       |                         |    |    | ■                   |               | Diodes 230 V            | 298  |
| MFT-2L.****  |           |        | 2       |       |                         |    |    |                     | ■             |                         | 298  |
| MFT-F.****.L |           |        | 1       | 1     |                         |    |    | > 4 A               | max. 4 A      |                         | 298  |
| MFT-F.****   |           |        |         | 1     |                         |    |    | > 4 A               | max. 4 A      |                         | 298  |
| MFT-2F.****  |           |        |         | 2     |                         |    |    | ■                   |               |                         | 298  |
| MFT-FT.0001  |           |        |         |       | ■                       |    |    |                     | ■             |                         | 298  |
| MFT-RNO.0006 |           |        |         |       |                         | ■  |    |                     | ■             | Relay 230 V             | 298  |
| MFT-RNC.0006 |           |        |         |       |                         |    | ■  |                     | ■             | Relay 230 V             | 298  |

<sup>1</sup> Sockets must be ordered separately.

### Sockets

| Model Number | 2-pole, 2-pin | 4-pole, 4-pin | Ambient Temperature<br>-20 ... 70 °C | Page |
|--------------|---------------|---------------|--------------------------------------|------|
| MFT-BASE.2P  | ■             |               | ■                                    | 298  |
| MFT-BASE.4P  |               | ■             | ■                                    | 298  |

Edition 912907 (US) / 220718 (EU) 06/2011

## Accessories

## Terminal Blocks

| Model Number | System    |           | Terminal Block | Cold Junction Module | Voltage Divider for 10 V Inputs | Cover for Terminal Block with Screw Terminals | Number of Poles | Housing Color |      | Page     |
|--------------|-----------|-----------|----------------|----------------------|---------------------------------|---|-----------------|---------------|------|----------|
|              | LB-System | FB-System |                |                      |                                 |   |                 | Green         | Blue |          |
| LB 9007 A    | ■         |           | ■              |                      |                                 |   | 6               | ■             |      | 170      |
| LB 9008 A    | ■         |           |                |                      |                                 | ■   | 6               | ■             |      | 170      |
| LB 9009 A    | ■         |           | ■              |                      |                                 |   | 6               | ■             |      | 170      |
| LB 9010 A    | ■         |           |                |                      |                                 | ■   | 8               | ■             |      | 170      |
| LB 9011 A    | ■         |           |                | ■                    |                                 |   | 6               | ■             |      | 170      |
| LB 9012 A    | ■         |           | ■              |                      | ■                               |   | 6               | ■             |      | 170      |
| LB 9013 A    | ■         |           | ■              |                      |                                 |   | 8               | ■             |      | 170      |
| LB 9014 A    | ■         |           | ■              |                      |                                 |   | 2 x 8           | ■             |      | 170      |
| LB 9015 A    | ■         |           | ■              |                      |                                 |   | 8               | ■             |      | 170      |
| LB 9016 A    | ■         |           | ■              |                      |                                 |   | 2 x 8           | ■             |      | 170      |
| LB 9017 A    | ■         |           | ■              |                      |                                 |   | 6               | ■             |      | 170      |
| LB 9018 A    | ■         |           | ■              |                      |                                 |   | 8               | ■             |      | 170      |
| LB 9019 A    | ■         |           | ■              |                      |                                 |   | 2 x 8           | ■             |      | 170      |
| LB 9107 A    | ■         | ■         | ■              |                      |                                 |   | 6               |               | ■    | 171, 256 |
| LB 9107 P    | ■         | ■         | ■              |                      |                                 |   | 6               |               | ■    | 171, 256 |
| LB 9108 A    | ■         | ■         |                |                      |                                 | ■   | 6               |               | ■    | 171, 256 |
| LB 9111 A    | ■         |           |                | ■                    |                                 |   | 6               |               | ■    | 171      |
| LB 9112 A    | ■         | ■         |                | ■                    |                                 |   | 6               |               | ■    | 171, 256 |
| LB 9113 A    | ■         | ■         | ■              |                      |                                 |   | 8               | ■             |      | 171, 256 |
| LB 9115 A    | ■         | ■         | ■              |                      |                                 |   | 8               |               | ■    | 171, 256 |
| LB 9116 A    | ■         | ■         | ■              |                      |                                 |   | 2 x 8           |               | ■    | 171, 256 |
| LB 9117 A    | ■         | ■         | ■              |                      |                                 |   | 6               |               | ■    | 171, 256 |
| LB 9118 A    | ■         | ■         | ■              |                      |                                 |   | 8               |               | ■    | 171, 256 |
| LB 9119 A    | ■         | ■         | ■              |                      |                                 |   | 2 x 8           |               | ■    | 171, 256 |
| LB 9120 A    | ■         | ■         |                |                      |                                 | ■   | 8               |               | ■    | 171, 256 |
| LB 9124 A    | ■         | ■         | ■              |                      |                                 |   | 2 x 8           |               | ■    | 171, 256 |
| LB 9125 A    |           | ■         | ■              |                      |                                 |   | 8               |               | ■    | 256      |
| LB 9126 A    |           | ■         | ■              |                      |                                 |   | 8               |               | ■    | 256      |
| LB 9127 A    |           | ■         | ■              |                      |                                 |   | 8               |               | ■    | 256      |

**Bus Connectors with Switchable Bus Termination Resistors**

| Model Number | System    |           | Description                                  | Page |
|--------------|-----------|-----------|--|------|
|              | LB-System | FB-System |  |      |
| LB 9001 A    | ■         |           | Sub-D connector, 9-pin, left cable entry     | 172  |
| LB 9002 A    | ■         |           | Sub-D connector, 9-pin, vertical cable entry | 172  |
| LB 9003 A    | ■         |           | Sub-D connector, 9-pin, left cable entry     | 172  |

**Bus Termination Modules**

| Model Number | System    |           | Description   | Page |
|--------------|-----------|-----------|---|------|
|              | LB-System | FB-System |   |      |
| FB 9293 B    |           | ■         | Bus Termination Module, service bus termination         | 255  |
| FB 9294 B    |           | ■         | Bus Termination Module, bus termination                 | 255  |
| FB 9295 B    |           | ■         | Bus Termination Module, bus and service bus termination | 255  |

**Further Accessories**

| Model Number | System    |           | Description                             | Page     |
|--------------|-----------|-----------|---|----------|
|              | LB-System | FB-System |   |          |
| KF-CP        | ■         | ■         | Coding pins, packaging unit 20 x 6, red | 173, 257 |
| F-NR-Ex1     | ■         | ■         | NAMUR Resistance Network                | 173, 257 |
| LB 9199 A    | ■         | ■         | Dummy I/O module                        | 173      |
| FB 927*-300  |           | ■         | Extension cable, 3 m                    | 257      |
| FB 9283-300  |           | ■         | Extension cable, 3 m                    | 257      |

Appendix

Glossary

Function Index

Model Number Index

## F

|                        |          |
|------------------------|----------|
| F-NR-Ex1               | 173, 257 |
| FB 1201 B              | 202      |
| FB 1202 B              | 203      |
| FB 1203 *              | 204      |
| FB 1208 B              | 205      |
| FB 1301 **             | 206      |
| FB 1302 **             | 207      |
| FB 1303 **             | 208      |
| FB 1308 **             | 209      |
| FB 2201 - FB 2213      | 212      |
| FB 2201 - FB 2213 SIL2 | 213      |
| FB 3202 B              | 222      |
| FB 3205 B              | 223      |
| FB 3302 **             | 224      |
| FB 3305 **             | 225      |
| FB 4202 B              | 234      |
| FB 4202 C              | 235      |
| FB 4205 C              | 236      |
| FB 4205 D              | 237      |
| FB 4302 B              | 238      |
| FB 4302 C              | 239      |
| FB 4305 C              | 240      |
| FB 4305 D              | 241      |
| FB 5201 B              | 226      |
| FB 5202 B              | 227      |
| FB 5204 B              | 228      |
| FB 5205 B              | 229      |
| FB 5206 B              | 230      |
| FB 6208 *              | 214      |
| FB 6210 - FB 6215      | 215      |
| FB 6210 - FB 6215 SIL2 | 216      |
| FB 6301 **             | 217      |
| FB 6305 **             | 218      |
| FB 6306 **             | 219      |
| FB 8206 H***           | 244      |
| FB 8207 H***           | 245      |
| FB 8209 H***           | 246      |
| FB 8210 H***           | 247, 277 |
| FB 8211 A              | 248      |
| FB 9205 C              | 250      |
| FB 9206 D              | 251      |
| FB 9210-PB0-0-0-0-0-F  | 258, 282 |

|                       |     |
|-----------------------|-----|
| FB 9210-PB0-0-0-0-0   | 259 |
| FB 9215 B             | 252 |
| FB 9216 B             | 252 |
| FB 9224-PG0-0-0-0-0   | 260 |
| FB 9224-PH0-0-0-0-0-0 | 261 |
| FB 9248-PG0-0-0-0-0-0 | 262 |
| FB 9248-S70-0-0-0-0   | 263 |
| FB 9249-PG0-0-0-0-0-0 | 264 |
| FB 9249-S80-0-0-0-0   | 265 |
| FB 927*-300           | 257 |
| FB 9283-300           | 257 |
| FB 9293 B             | 255 |
| FB 9294 B             | 255 |
| FB 9295 B             | 255 |
| FOL 7250 B 059        | 290 |
| FOL 7250 B 159        | 290 |
| FOL 7250 B 259        | 290 |

## K

|       |          |
|-------|----------|
| KF-CP | 173, 257 |
|-------|----------|

## L

|                        |     |
|------------------------|-----|
| LB 1001 A              | 112 |
| LB 1002 A              | 113 |
| LB 1003 *              | 114 |
| LB 1008 A              | 115 |
| LB 1015 A              | 116 |
| LB 1101 A              | 117 |
| LB 1102 A              | 118 |
| LB 1103 *              | 119 |
| LB 1108 A              | 120 |
| LB 2002 *              | 124 |
| LB 2101 - LB 2113      | 125 |
| LB 2101 - LB 2113 SIL2 | 126 |
| LB 3002 A              | 138 |
| LB 3005 A              | 139 |
| LB 3102 A              | 140 |
| LB 3105 A              | 141 |
| LB 4002 A              | 152 |
| LB 4005 D              | 153 |
| LB 4102 A              | 154 |
| LB 4102 C              | 155 |
| LB 4105 C              | 156 |

|                       |                                  |                     |                                 |          |
|-----------------------|----------------------------------|---------------------|---------------------------------|----------|
| <b>Appendix</b>       | LB 4105 D . . . . .              | 157                 | LB 9024 S . . . . .             | 178      |
|                       | LB 5004 A . . . . .              | 142                 | LB 9025 A . . . . .             | 180      |
|                       | LB 5005 A . . . . .              | 143                 | LB 9026 A . . . . .             | 181      |
|                       | LB 5101 A . . . . .              | 144                 | LB 9027 A . . . . .             | 182      |
|                       | LB 5102 A . . . . .              | 145                 | LB 9029 A . . . . .             | 183      |
|                       | LB 5104 A . . . . .              | 146                 | LB 9035 A . . . . .             | 184, 280 |
|                       | LB 5105 A . . . . .              | 147                 | LB 9107 A . . . . .             | 171, 256 |
|                       | LB 5106 A . . . . .              | 148                 | LB 9107 P . . . . .             | 171, 256 |
|                       | LB 6005 A . . . . .              | 127                 | LB 9108 A . . . . .             | 171, 256 |
|                       | LB 6006 A . . . . .              | 128                 | LB 9111 A . . . . .             | 171      |
| <b>Glossary</b>       | LB 6008 * . . . . .              | 129                 | LB 9112 A . . . . .             | 171, 256 |
|                       | LB 6010 A . . . . .              | 130                 | LB 9113 A . . . . .             | 171, 256 |
|                       | LB 6010 SIL2 . . . . .           | 131                 | LB 9115 A . . . . .             | 171, 256 |
|                       | LB 6101 H . . . . .              | 132                 | LB 9116 A . . . . .             | 171, 256 |
|                       | LB 6108 * . . . . .              | 133                 | LB 9117 A . . . . .             | 171, 256 |
|                       | LB 6110 - LB 6115 . . . . .      | 134                 | LB 9118 A . . . . .             | 171, 256 |
|                       | LB 6110 - LB 6115 SIL2 . . . . . | 135                 | LB 9119 A . . . . .             | 171, 256 |
|                       | LB 8106 H*** . . . . .           | 160                 | LB 9120 A . . . . .             | 171, 256 |
|                       | LB 8107 H*** . . . . .           | 161                 | LB 9124 A . . . . .             | 171, 256 |
|                       | LB 8109 H*** . . . . .           | 162                 | LB 9125 A . . . . .             | 256      |
| <b>Function Index</b> | LB 8110 H*** . . . . .           | 163, 276            | LB 9126 A . . . . .             | 256      |
|                       | LB 8111 A . . . . .              | 164                 | LB 9127 A . . . . .             | 256      |
|                       | LB 9001 A . . . . .              | 172                 | LB 9199 A . . . . .             | 173      |
|                       | LB 9002 A . . . . .              | 172                 | LB 9508-S92-0-0-1-0-0 . . . . . | 185      |
|                       | LB 9003 A . . . . .              | 172                 | LB 9510-S90-0-0-1-0-F . . . . . | 186, 281 |
|                       | LB 9006 C . . . . .              | 166                 | LB 9513-PB0-0-0-1-0-0 . . . . . | 187      |
|                       | LB 9007 A . . . . .              | 170                 | LB 9516-PB0-0-0-1-0-0 . . . . . | 188      |
|                       | LB 9008 A . . . . .              | 170                 | LB 9547-S70-0-0-1-0-0 . . . . . | 190      |
|                       | LB 9009 A . . . . .              | 170                 | LB 9547-S70-0-0-1-0-M . . . . . | 189      |
|                       | <b>Model Number Index</b>        | LB 9010 A . . . . . | 170                             |          |
| LB 9011 A . . . . .   |                                  | 170                 |                                 |          |
| LB 9012 A . . . . .   |                                  | 170                 |                                 |          |
| LB 9013 A . . . . .   |                                  | 170                 |                                 |          |
| LB 9014 A . . . . .   |                                  | 170                 |                                 |          |
| LB 9015 A . . . . .   |                                  | 170                 |                                 |          |
| LB 9016 A . . . . .   |                                  | 170                 |                                 |          |
| LB 9017 A . . . . .   |                                  | 170                 |                                 |          |
| LB 9018 A . . . . .   |                                  | 170                 |                                 |          |
| LB 9019 A . . . . .   |                                  | 170                 |                                 |          |
| LB 9022 A . . . . .   |                                  | 174                 |                                 |          |
| LB 9022 E . . . . .   |                                  | 175                 |                                 |          |
| LB 9022 S . . . . .   |                                  | 177                 |                                 |          |
| LB 9023 A . . . . .   |                                  | 179                 |                                 |          |
| LB 9024 A . . . . .   |                                  | 176                 |                                 |          |

Edition 912907 (US) / 220718 (EU) 06/2011

**M**

|                   |     |
|-------------------|-----|
| MFT-2D.0500 ..... | 298 |
| MFT-2F.**** ..... | 298 |
| MFT-2L.**** ..... | 298 |
| MFT-2R.**** ..... | 298 |
| MFT-BASE.2P.....  | 298 |
| MFT-BASE.4P.....  | 298 |
| MFT-D.1000 .....  | 298 |
| MFT-D.1000.L..... | 298 |
| MFT-F.**** .....  | 298 |
| MFT-F.****.L..... | 298 |
| MFT-FT.0001 ..... | 298 |
| MFT-R.**** .....  | 298 |
| MFT-RNC.0006..... | 298 |
| MFT-RNO.0006..... | 298 |





# PROCESS AUTOMATION – PROTECTING YOUR PROCESS



For over a half century, Pepperl+Fuchs has been continually providing new concepts for the world of process automation. Our company sets standards in quality and innovative technology. We develop, produce and distribute electronic interface modules, Human-Machine Interfaces and hazardous location protection equipment on a global scale, meeting the most demanding needs of industry. Resulting from our world-wide presence and our high flexibility in production and customer service, we are able to individually offer complete solutions – wherever and whenever you need us. We are the recognized experts in our technologies – Pepperl+Fuchs has earned a strong reputation by supplying the world's largest process industry companies with the broadest line of proven components for a diverse range of applications.

## 1 Worldwide/German Headquarters

Pepperl+Fuchs GmbH  
Mannheim · Germany  
Tel. +49 621 776 2222  
E-Mail: [pa-info@pepperl-fuchs.com](mailto:pa-info@pepperl-fuchs.com)

## 2 Asia Pacific Headquarters

Pepperl+Fuchs PTE Ltd.  
Singapore  
Company Registration No. 199003130E  
Tel. +65 6779 9091  
E-Mail: [pa-info@sg.pepperl-fuchs.com](mailto:pa-info@sg.pepperl-fuchs.com)

## 3 Western Europe & Africa Headquarters

Pepperl+Fuchs N.V.  
Schoten/Antwerp · Belgium  
Tel. +32 3 6442500  
E-Mail: [pa-info@be.pepperl-fuchs.com](mailto:pa-info@be.pepperl-fuchs.com)

## 4 Middle East/India Headquarters

Pepperl+Fuchs M.E (FZE)  
Dubai · UAE  
Tel. +971 4 883 8378  
E-mail: [pa-info@ae.pepperl-fuchs.com](mailto:pa-info@ae.pepperl-fuchs.com)

## 5 North/Central America Headquarters

Pepperl+Fuchs Inc.  
Twinsburg · Ohio · USA  
Tel. +1 330 486 0002  
E-Mail: [pa-info@us.pepperl-fuchs.com](mailto:pa-info@us.pepperl-fuchs.com)

## 6 Northern Europe Headquarters

Pepperl+Fuchs GB Ltd.  
Oldham · England  
Tel. +44 161 6336431  
E-Mail: [pa-info@gb.pepperl-fuchs.com](mailto:pa-info@gb.pepperl-fuchs.com)

## 7 Southern/Eastern Europe Headquarters

Pepperl+Fuchs s.r.l.  
Sulbiate (MB) · Italy  
Tel. +39 039 62921  
E-Mail: [pa-info@it.pepperl-fuchs.com](mailto:pa-info@it.pepperl-fuchs.com)

## 8 Southern America Headquarters

Pepperl+Fuchs Ltda.  
São Bernardo do Campo · SP · Brazil  
Tel. +55 11 4007 1448  
E-Mail: [pa-info@br.pepperl-fuchs.com](mailto:pa-info@br.pepperl-fuchs.com)

[www.pepperl-fuchs.com](http://www.pepperl-fuchs.com)

 **PEPPERL+FUCHS**  
PROTECTING YOUR PROCESS